



532-16B MANURE SPREADER TRAILER UNIT



OPERATION AND PARTS MANUAL

ROTO-MIX LLC
2205 E. Wyatt Earp
PO Box 1724
Dodge City, Kansas 67801
(620) 225-1142

©Roto-Mix 2006

INTRODUCTION

Congratulations on the purchase of your new spreader from Roto-Mix. With proper operation and preventative maintenance it will last for years.



This SAFETY ALERT SYMBOL indicates important safety messages in the manual. When you see this symbol, be alert to the possibility of PERSONAL INJURY and carefully read the message that follows.

⚠ WARNING NEVER OPERATE WITHOUT ALL COVERS, SHIELDS AND GUARDS IN PLACE. KEEP HANDS, FEET AND CLOTHING AWAY FROM MOVING PARTS.

Some covers and guards have been removed for illustrative/photographic purposes only in this manual. However, equipment should never be operated in this condition. Keep all shields in place. If shield removal becomes necessary for repairs, replace the shield prior to use.

The Guarantee appears in the front of this book along with the Registration and Inspection Certificate.

For information on ordering repair parts, refer to the Repair Parts section at the back of this book.

The serial number plate is located on the drivers side lower front of the main frame. This number should be recorded on the Registration and Inspection Certificate for your reference and for proper identification of your spreader by Roto-Mix.

You are urged to study this manual and follow the instructions carefully. Your efforts will be repaid in better operation and service as well as a savings in time and repair expense.

Failure to read and understand the machine or the system could lead to serious injury.

If you do not understand the instructions in this manual contact either your dealer or Roto-Mix at Dodge City, Kansas 67801.

This supersedes all previous published instructions.



Limited Warranty Statement

ROTO-MIX LLC warrants to the original purchaser all products manufactured by it to be free from defects in material and workmanship under normal use and service.

ROTO-MIX's obligation under this warranty is limited to repairing or replacing, as the company may elect, free of charge and without charge for installation, at the place of business of a dealer or distributor authorized to handle the equipment covered by this warranty or at a ROTO-MIX facility, any parts that prove, in the company's judgment, to be defective in material or workmanship within one (1) year after delivery to the original purchaser, and still owned by the original purchaser. This warranty shall in no way make ROTO-MIX liable to anyone for personal injuries or damages, loss of time, or expense of any kind either direct or indirect resulting from part failure or defect. This warranty is subject to acts of God, fire and existing conditions of supply and demand, or production, or ability or inability to deliver, or for any other valid reason beyond the reasonable control of ROTO-MIX, to obtain materials, manufactured replacement parts, or make delivery thereof. No distributor, dealer, agent, or ROTO-MIX employee (other than the CEO or President in writing) is authorized to extend any other or further express or implied warranty or incur any additional obligation on ROTO-MIX's behalf in connection with the sale of this product.

If ROTO-MIX, or its duly authorized representative, shall find that such returned part or parts are defective and such defects, or defect, are included in and covered by said warranty, then such defective part or parts shall promptly be replaced without charge to the purchaser, F.O.B. the ROTO-MIX plant.

Product Registration - It is a condition of this warranty that the original purchaser must fill out the warranty card furnished by ROTO-MIX and that it be returned to ROTO-MIX within 10 days of purchase and be recorded in ROTO-MIX's owner file for this warranty to be valid. In the event an owner's card is not on file at the ROTO-MIX office, the warranty period will extend only from date equipment was picked up or shipped from the ROTO-MIX plant.

Maintenance - It is the customer's responsibility to maintain their equipment in accordance with the instructions provided in the Operator's Manual. ROTO-MIX recommends that you keep records and receipts; you may be asked to prove that maintenance instructions have been followed.

Operation - It is the customer's responsibility to operate the equipment only for the purpose for which it was designed and in accordance with all safety and operational recommendations contained in the Operators Manual. If a defect in materials or workmanship occurs, it is the customer's responsibility to cease operating the equipment until authorized repairs are made. **Damage, which occurs from continued operation, may not be covered by this warranty.**

What this Warranty Covers

This warranty covers failures caused by defects in materials or workmanship only.

This Warranty does not cover failures caused by:

- Improper operation
- Natural calamities
- Unauthorized modifications
- Unauthorized repairs
- Use of Non ROTO-MIX parts
- Neglected maintenance
- The use of PTO Shaft Adaptors
- Usage contrary to the intended purpose of the product

This Warranty does not cover replacement of Wear or Maintenance Items including, but not limited to.

- Lubricants
- Filters
- Hoses
- Tires
- Augers
- Wipers
- Chains
- Idlers
- Batteries
- Blades
- Belts

This Warranty does not cover:

- Pickup and delivery of the equipment
- Service Calls or Travel Time to and from sites
- Rental of replacement equipment during repair period
- Products that have been declared a total loss and subsequently salvaged
- Overtime labor charges
- ROTO-MIX is not responsible and will not be liable for damage caused to persons or property, commercial loss, loss of time or production, loss of use by reason of the installation or use of ROTO-MIX products or their mechanical failure.

Right to Make Changes

ROTO-MIX reserves the right to make any changes to a ROTO-MIX product at any time without incurring any obligation with respect to any product previously ordered, sold or shipped, with or without notice.

Parts Warranty

ROTO-MIX warranties replacement parts against defects in materials or workmanship for a period of 90 days or the remainder of the product warranty, whichever is longer. Remedy for defective replacement parts for units that are beyond the original product warranty, will be limited to replacement of the failed part. Failures that are due to damage, improper installation, lack of maintenance or improper operation will not be covered.

ROTO-MIX 2205 East Wyatt Earp Blvd., Dodge City, KS 67801 (620) 225-1142 Fax: (620) 225-6370

TABLE OF CONTENTS

DESCRIPTION	PAGE NO.
Introduction	2
Warranty	3
Table Of Contents	4
Safety-Spreader	5
Safety Decals	6
Spreader Safety	7
Safety Decal Care	10
Specifications	11
Dimensional Data	11
Tractor Hydraulic System Recommendations	12
Features	12
Optional Equipment.....	12
Principle of Operation	12-13
Pre Operation Check List	14
Highway and Transport Operation	14
Operation	15
Loading	16
Unloading	17
Storage and Cleaning	17
Maintenance	19
Lubrication	19
Bearings	19
Drive Chain Planetary Gearbox	19
Hydraulic System	20
Adjustments	20
Sliding Gate Scrapers	20
Rear Gate Scrapers	21
Rear Gate Scrapers	21
Drive Chain Slack.....	21
Adjust Spread Pattern	22
Repair Parts	23

SAFETY - SPREADER

A brief definition of signal words that may be used in this manual:

⚠ DANGER Indicates an imminently hazardous situation that, if not avoided, will result in death or serious injury.

⚠ WARNING Indicates a potentially hazardous situation that, if not avoided could result in death or serious injury, and includes hazards that are

⚠ CAUTION Indicates a potentially hazardous situation that, if not avoided may result in minor or moderate injury.



NOTE: Complete decal kit part number for 532-16B is 630042.



Decal B. 440833



Decal A. 440827



Decal C. 440801

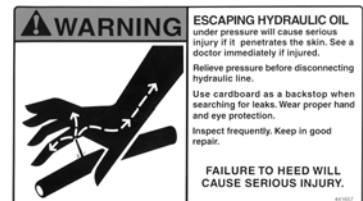

Decal D. 441657

⚠ CAUTION READ ALL SIGNS ON THE MACHINE AND IN THIS MANUAL. REPLACE ANY LOST OR DAMAGED SIGN BY ORDERING THE PART NUMBERS SHOWN ON THE SAFETY DECAL PAGE.

SPREADER SAFETY

CAUTION

Do not operate your spreader until you have read this Owner's Manual, the Tractor Owner's Manual, and understand the danger associated with its operation.

This spreader is comprised of rotating drive shafts and rotating beaters. Any exposure to these spreader components can result in serious personal injury or death.

Study the safety decal page and understand where the danger points are.

CAUTION

THERE ARE INHERENT HAZARDS ASSOCIATED WITH THE OPERATION OF YOUR SPREADER.

FOR YOUR SAFETY:

- Do not operate, service, inspect or otherwise handle this equipment unless you have read the owner's manual and have been properly trained in its intended usage.
- Do not attempt to operate this equipment under the influence of drugs or alcohol.
- Do not allow personnel other than the qualified operator near the machine.
- Require all personnel who will operate this machinery or perform service, to read and understand the safe operating practices and safety precautions in this manual.
- Before starting tractor engine, be sure pto shields turn freely.
- Do not operate until all shields, covers and guards are in place.
- Do not allow children or inexperienced persons to operate this machine.
- Keep hands, feet and clothing away from power take-off shaft.
- Loose or floppy clothing should not be worn by the operator. Wear close fitting clothing.
- Stop the engine and be sure pto drive line is stopped before making adjustments, connections, or cleaning out pto driven equipment.
- Do not climb on or enter machine while in operation.
- Do not allow riders on the spreader.
- Rotating parts can crush or dismember causing personal injury or death.
- Rotating parts can entangle or strike people, resulting in personal injury or death.
- Operate the spreader from the operator's seat only.
- Clear the area before equipment start up.
- Do not go near the spreader beaters while machine is operating.
- Stay clear of rotating drive lines.

SPREADER SAFETY

- Entanglement in rotating drive line can cause serious injury or death.
- Make sure rotating shields turn freely.
- Do not exceed load capacity of the spreader (see specifications).
- Always use a tractor large enough to provide sufficient braking assistance when towing a loaded spreader.
- Do not load the spreader unless it is hitched to the tractor.
- Do not unhitch a loaded spreader from the tractor leaving it supported by only the jack.
- Reduce speed when turning or traveling on rough terrain. Avoid traveling over loose fill, rocks, ditches or holes.
- Do not operate on steep slopes as overturn may result. Operate up and down (not across) intermediate slopes. Avoid sudden starts and stops. Pick the most level possible route when transporting across fields. Avoid the edges of ditches or gullies and steep hillsides.
- Use caution when traveling over uneven terrain and when approaching stops.
- Keep transmission in gear when traveling downhill.
- Keep tractor master shield and drive line shields in place at all times.
- Avoid overhead wires or other obstacles. Contact with overhead lines could cause serious injury or death.
- Highway travel is not to exceed 20 mph. The tires supplied are for farm use only and are not designed for use above this speed.
- Use adequate safety chains when towing the spreader.
- The use of a slow moving vehicle sign is required on all public roads. Obey all applicable highway safety laws and rules.
- As a precaution, always recheck the hardware on spreader following every 100 hours of operation. Correct all problems. Follow the maintenance safety procedures.

FAILURE TO HEED MAY RESULT IN SERIOUS PERSONAL INJURY OR DEATH.

SPREADER SAFETY

⚠ CAUTION

THERE ARE ADDITIONAL HAZARDS ASSOCIATED WITH THE SERVICE AND MAINTENANCE OF YOUR SPREADER.

FOR YOUR SAFETY:

- Always wear eye protection when operating or servicing spreader.
- Disengage power take-off and remove keys from tractor or truck before servicing spreader.
- Do not attempt to clean, oil or adjust spreader while it is in motion.
- Stop the engine and be sure pto drive line is stopped before making adjustments, connections, or cleaning out pto driven equipment. Disconnect pto shaft.
- Make sure there is plenty of ventilation. Never operate the engine of the towing vehicle in a closed building. The exhaust fumes may cause asphyxiation.
- Before working on the spreader, stop the towing vehicle, set the brakes, disengage the pto and all power drives, shut off the engine and remove the ignition keys.
- Inspect when first delivered and regularly thereafter; that all connections and bolts are tight and secure before operating.
- Retighten all wheel bolts after the first hour of towing. Check periodically thereafter. See maintenance, wheels.
- Maintain proper tire air pressure at all times. 700/40-22.5 heavy duty flotation tires should be inflated to 85 PSI.
- Be certain all moving parts on attachments have come to a complete stop before attempting to perform maintenance.
- Before entering mixing chamber or servicing spreader, disconnect main power source and lock the disconnect device in off position to prevent accidental start-up.
- Do not work under a spreader without supporting with suitable support stands. Always use a safety support and block the wheels. Never use a jack to support the machine.
- Do not work under a spreader without blocking the wheels to prevent rolling.
- A fire extinguisher and first aid kit should be kept readily accessible while performing Maintenance On This Spreader.
- Escaping hydraulic fluid under pressure can penetrate the skin causing serious injury or death.
- Avoid hydraulic hazard by relieving hydraulic pressure before disconnecting hydraulic or other lines. Tighten all connections before applying pressure.
- Search for hydraulic leaks with a piece of cardboard. Protect hands and body from high pressure fluids. Never use your hands to locate hydraulic leaks on attachments.
- Replace all shields and guards after servicing and before moving.
- Never replace hex bolts with less than grade five (#5) bolts unless otherwise specified.

SPREADER SAFETY

FAILURE TO HEED MAY RESULT IN SERIOUS PERSONAL INJURY OR DEATH.

REMEMBER:

Your best assurance against accidents is a careful and responsible operator. If there is any portion of this manual or function you do not understand, contact your dealer or the ROTO-MIX plant.

Safety Decal Care

1. Keep safety decals and signs clean and legible at all times.
2. Replace safety decals and signs that are missing or have become illegible.
3. Replaced parts that displayed a safety sign should also display the current sign.
4. Safety decals or signs are available from your dealer or the ROTO-MIX manufacturing plant.
5. How to Install Safety Decals:
 - A. Be sure that the installation area is clean and dry.
 - B. Decide on the exact position before you remove the backing paper.
 - C. Remove the smallest portion of the split backing paper.
 - D. Align the decal over the specified area and carefully press the small portion with the exposed sticky backing in place.
 - E. Slowly peel back the remaining paper and carefully smooth the remaining portion of the decal in place.
 - F. Small air pockets can be pierced with a pin and smoothed out using the piece of decal backing paper.

FAILURE TO HEED MAY RESULT IN SERIOUS PERSONAL INJURY OR DEATH.

PRACTICE FIRE PREVENTION

Keep fire extinguishers accessible at all times. Use the extinguisher recommended for the material being processed. It should be rated safe for use on electrical fires.

Never smoke close to combustible material.

Clean the area before welding or other activities which may make sparks.

Keep all components that generate excessive heat clear of oil and other combustible materials.

SPECIFICATIONS

Roto-Spread	532-16B TRAILER
Capacity (Heaped)	530 Cubic Foot
Struck Level	385 Cubic Foot or 2,880 Gallon
Spreader Weight (Empty)	13,800 Lbs
Load Capacity (Net)	34,000 Lbs
Tongue Weight	900 Lbs Empty, 4,500 Lbs Loaded
Inside Dimensions	48" High, 71 1/2" Wide, 192" Long
Overall Width	110"
Overall Length	353"
Overall Height (Gate Lowered)	139"
Overall Height (Gate Raised)	163 1/2"
Unload Speed/Time	Variable
Discharge Height	55-1/2"
Spread Coverage	12' to 30'
Recommended PTO HP	150 (Minimum)
Beater Drive	PTO Driven Double Pump Driving 2 High Torque Motors.
Belt Drive/Rear Gate	Uses Tractor PTO Hydraulics. Belt Drive Speed Regulated by an Adjustable Flow Control Valve.
Beaters	Two 35" Diameter High Speed Vertical Beaters with Spinners, and Double Flighting, 300 RPM @ 1000 PTO RPM
Belt Material & Chain	5/16" 350 PSI PVC Belt & WH124 H.D. Combination Chain for Belt and Retention Gate Drive System
Floor, Gate & Side Walls	High Density Polyethylene on Floor, Side Walls and End Gate
Tire Size	24 x 22.5 Wheel With 700/40-22.5 H.D. Floatation Tire

All Dimensions & Specifications are Approximate and Subject to Change Without Notice.

SPECIFICATIONS

532-16B TRAILER DIMENSIONAL DATA

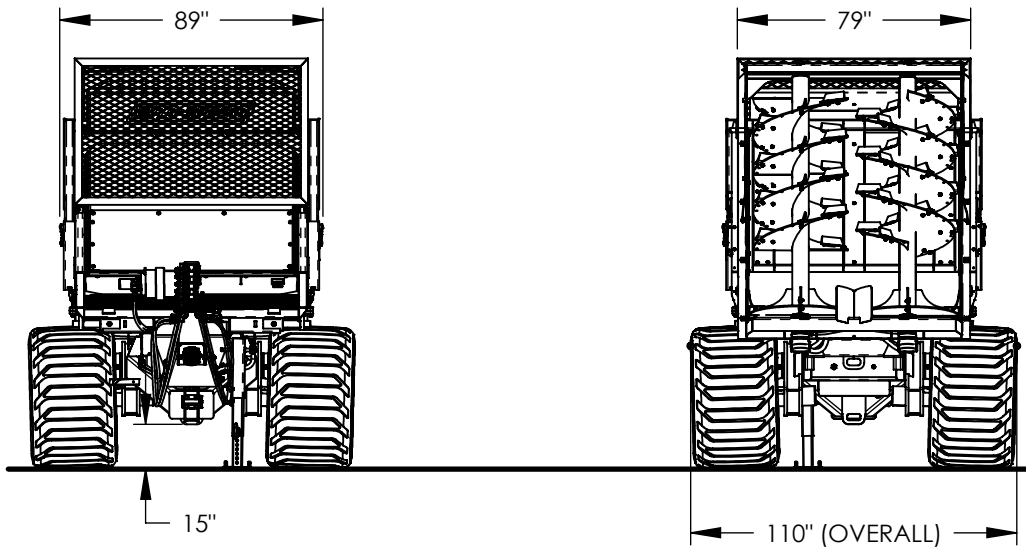
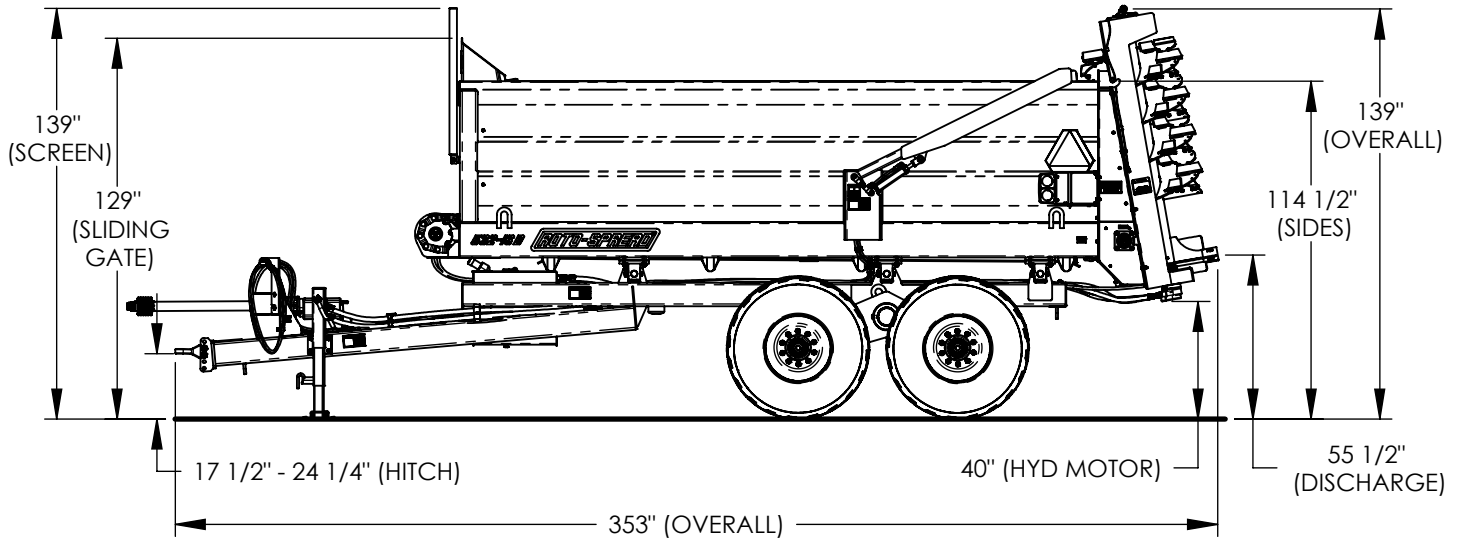

All Dimensions & Specifications are Approximate and Subject to Change Without Notice.

PRINCIPLE OF OPERATION

Two vertical spinning beaters at the rear of the spreader expel manure in a uniform spread pattern. Each beater is driven by a hydraulic motor. A PTO driven hydraulic power supply on the spreader provides power to the beaters. The hydraulic pump is two stage thereby supplying independent power to each beater motor.

A wide heavy duty belt covers the box floor. At the front of the spreader, this belt is attached to a sliding gate. At the rear, this belt goes around a winged idler pulley and on the lower side is connected to a drive chain. At the front of the spreader, this chain is driven by a hydraulic motor driving a planetary gear box and sprocket that is powered by the tractor hydraulic system. Driving the belt toward the rear of the spreader pulls the sliding gate rearward to move the load toward the beaters. A manually adjustable flow control in the drive chain motor circuit regulates the speed the gate moves.

An end gate at the rear of the spreader is raised and lowered by two hydraulic cylinders, powered by the tractor hydraulic system. This gate must be lowered during loading to prevent packing of the material into the beaters and to help prevent leakage during transport.

PRE OPERATION

UNDERSTAND THE CONTROLS

Rear Gate

The rear gate cylinders are hydraulically controlled by a tractor spool valve. It is recommended that the hoses be connected to the tractor so pulling the spool valve lever back raises the gate and pushing the valve lever forward closes it. Make it a habit to connect the hoses the same so the Operator is familiar with this operation.

Sliding Gate

The unloading belt which moves the sliding gate is powered by a hydraulic motor and planetary gearbox. This motor is powered from the tractor hydraulic system and started and stopped by the tractor spool valve for the port to which this motor is connected. It is recommended that the hoses be connected to the tractor so pulling the spool valve lever back starts the gate rearward and pushing the valve lever forward returns the gate to the front. The gate can be stopped by moving the spool valve lever to the neutral detent. Make it a habit to connect the hoses the same so the Operator is familiar with this operation.

NOTE: Set the tractor hydraulic selective control valve to 8 - 12 gallons per minute. Too much hydraulic flow will cause the floor belt and sliding gate to stop and not move, too little flow will cause the belt and sliding gate to move too slowly.

When the sliding gate reaches the rear of the spreader it will bear against mechanical stops. The tractor hydraulic system will sense increased hydraulic pressure and return the spool valve to the neutral OFF position. The same process occurs when returning the gate to the front.

Rate Of Application

The rate of application is determined by how fast the sliding gate and belt (floor) progresses toward the rear of the spreader. This is regulated by a remote adjusted flow control valve in the tractor. See figure 1.

The remote flow control knob is turned CW to increase the rate and CCW to decrease the rate. Completely CCW is OFF.

NOTE: If the belt speed is too fast the material will overload the beaters and cause them to stall and

the warning horn to sound.

Start with a slow rate and then increase as required. Once adjusted, the unloading rate will remain constant for the same type of material. Further application rate adjustment can be obtained by regulating the tractor ground speed. The application rate is not affected by engine RPM.

Spread Pattern

The spread pattern is affected by the speed of the rotating beaters. The two beater hydraulic motors are powered independently by a two stage hydraulic pump on the spreader. This pump is powered by the tractor PTO. The spreader is designed to give a uniform spread pattern when the tractor engine is operated at 1000 PTO RPM for typical materials. Adjustment of the beater speed and spread pattern is regulated by the engine speed.

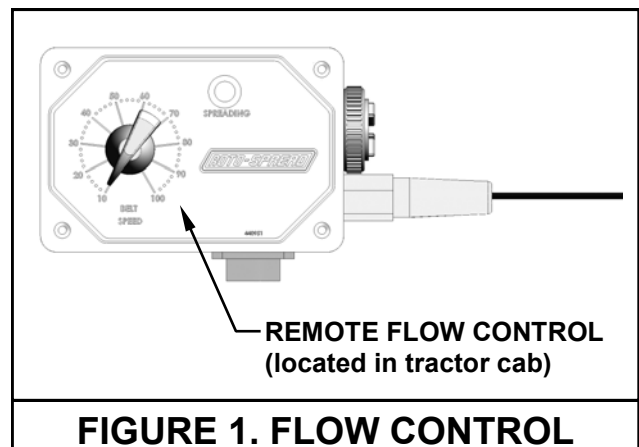

TRACTOR DRAWBAR

Set tractor drawbar as shown in figure 2. Spreaders are available for 1000 RPM drive line only. Match tractor PTO with the spreader drive line.

IMPORTANT: To prevent drive line damage, adjust tractor drawbar to recommended setting. Disengage tractor PTO before turning.

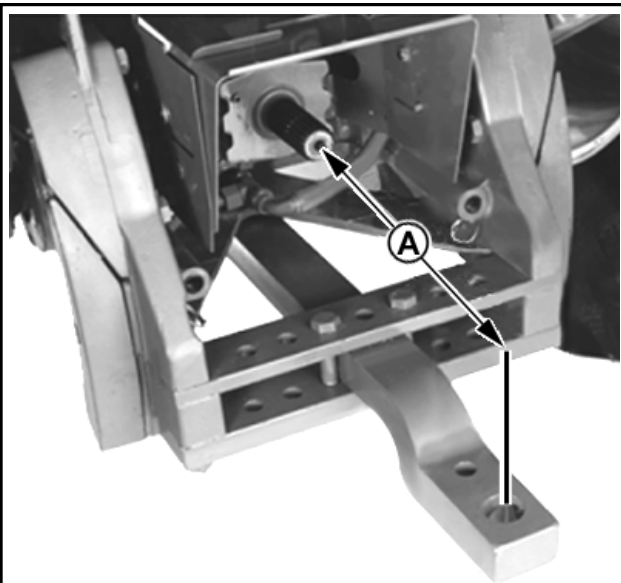

PTO SHAFT	PTO Shaft End to Hitch Pin Hole (A)
1000 RPM 1-3/8", 21 Spline	14"
1000 RPM 1-3/4", 20 Spline	20.9"

FIGURE 2. TRACTOR DRAWBAR

CAUTION FAILURE TO SET DRAWBAR PROPERLY MAY CAUSE SHAFT TO OVER EXTEND AND SEPARATE OR BEND WHEN CORNERING OR TRANSPORTING RESULTING IN DEATH OR PERSONAL INJURY.

Adjust Trailer Hitch

Spreader should be approximately level when attached to tractor.

Trailer hitch has 4 positions.

PRE OPERATION CHECKLIST

1. Carefully study and understand this manual.
2. Do not wear loose-fitting clothing, which may catch in moving parts.
3. Always wear protective clothing *and* substantial shoes.
4. Keep wheel lug nuts or bolts tightened to 450 FT/LBS, dry threads.
5. Assure that agricultural implement tires are inflated evenly and at proper pressure.
6. Give the unit a visual inspection for any loose bolts, worn parts or cracked welds, and make necessary repairs. Follow the maintenance safety instructions included in this manual.
7. Check to see that no obstructions are present in the spreader prior to start up.
8. Be sure that there are no tools lying on or in the spreader.
9. Do not use the unit until you are sure that the area is clear, especially children and animals.
10. The ball valve in the suction line must be open prior to engaging PTO (handle parallel with valve housing).
11. Because it is possible that this spreader may be used in dry areas or the presence of combustibles, special precautions should be taken to prevent fires and fire fighting equipment should be readily available.
12. Don't hurry the learning process or take the unit for granted. Ease into it and become familiar with your new spreader.
13. Practice operation of your spreader and its attachments. Completely familiarize yourself and other operators with its operation before using.
14. Securely attach to towing unit. Use a high strength, appropriately sized hitch pin with a mechanical retainer.
15. Do not allow anyone to stand between the tongue or hitch and the towing vehicle when backing up to the spreader.

HIGHWAY AND TRANSPORT OPERATION

1. Adopt safe driving practices:
2. Always drive at a safe speed relative to local conditions and ensure that your speed is low enough for an emergency stop to be safe and secure. Keep speed to a minimum.
3. Reduce speed prior to turns to avoid the risk of overturning.
4. Avoid sudden uphill turns on steep slopes.
5. Always keep the tractor in gear to provide engine braking when going downhill. Do not coast.
6. Do not drink and drive.
7. Comply with state and local laws governing highway safety and movement of farm machinery on public roads.
8. Use approved accessory lighting flags and necessary warning devices to protect operators of other vehicles on the highway during daylight and night time transport.
9. The use of flashing amber lights is acceptable in most localities. However, some localities prohibit their use. Local laws should be checked for all highway lighting and marking requirements.
10. The spreader does not have brakes. Towing the spreader must be done safely. The ASAE (American Society of Agricultural Engineers) specifies that the towing vehicle should weigh at least 2/3 as much as the loaded implement to be reasonably safe towing at speeds up to 20 mph. This (20 mph) is also the maximum recommended towing speed for the spreader.
11. When driving the tractor and spreader on the road or highway at night or during the day, use flashing amber warning lights and a slow moving vehicle (SMV) identification emblem.
12. Be sure the slow moving vehicle sign is installed on the rear of the spreader for transporting on roadways.
13. Plan your route to avoid heavy traffic.
14. Be a safe courteous driver. Always yield to oncoming traffic in all situations, including narrow bridges, intersections, etc.
15. Be observant of bridge loading ratings. Do not cross bridges rated lower than the gross weight at which you are operating.
16. Watch for obstructions overhead and to the side while transporting.
17. Make allowances for increased length and

weight of the spreader when making turns, stopping the unit, etc.

18. Install safety chains as illustrated on figure 3. This is a requirement for travel on public roadways. They are installed to retain the connection between tractor (or other towing vehicle) and spreader whenever traveling on public roads.

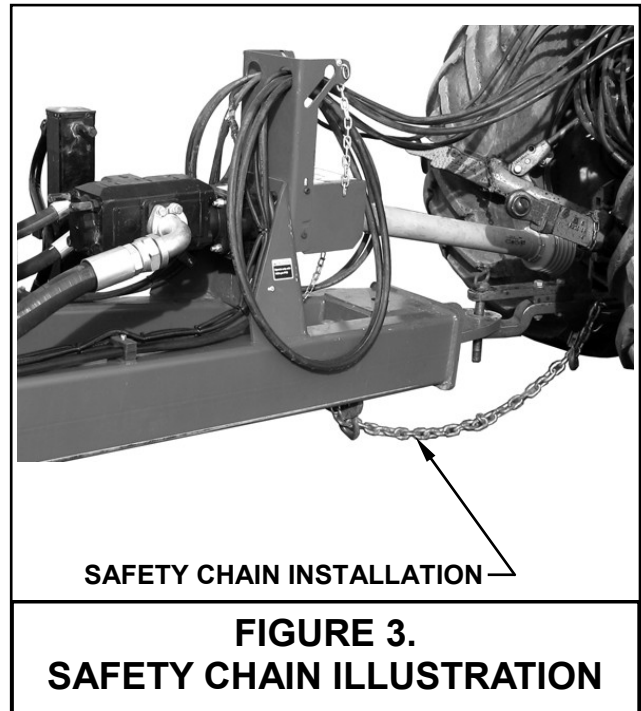

LIGHTING & MARKING

Hazard lights are standard equipment on the spreader, When towing on roads extend the hazard light brackets to the out position.

OPERATION

⚠ WARNING DO NOT CLIMB ON OR ENTER THE SPREADER WHILE IN OPERATION.

⚠ WARNING CLEAR THE AREA OF ALL PERSONS BEFORE BEGINNING OPERATION.

TRACTOR HOOKUP

See figure 4.

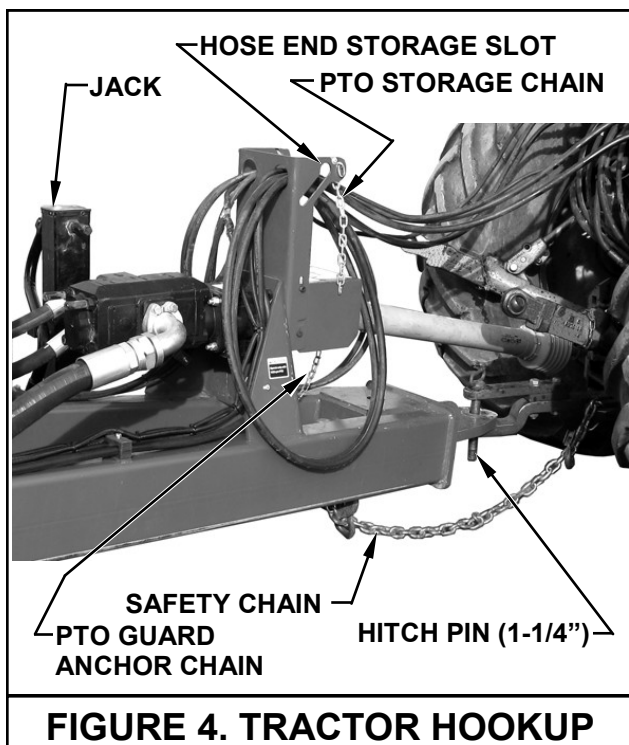

FIGURE 4. TRACTOR HOOKUP

1. Back tractor so draw bar aligns with spreader hitch. Put tractor in PARK, set park brake and turn off engine before dismounting.
2. Connect the spreader hitch to the tractor drawbar with a 1-1/4" hitch pin. The hitch pin must have a security clip or retainer to prevent it from accidentally coming out of the hitch.
3. Install safety chain around tractor drawbar support and secure with safety latched grab hook. See figure 3.
4. Crank the spreader jack completely up.
5. Remove the pair of hydraulic hoses coming from the spreader hydraulic pump from their

storage bracket and connect the ends to a tractor port. See Understand The Controls on page 12 for recommended connection.

6. Remove the pair of hydraulic hoses coming from the spreader rear gate hydraulic cylinders from their storage bracket and connect the ends to a tractor port. See Understand The Controls on page 12 for recommended connection.
7. Unhook the PTO storage chain from the slotted storage bracket and slide the PTO drive shaft yoke onto the splined tractor PTO shaft. Be sure the yoke securely snaps onto the retention groove of the tractor shaft.
8. Connect the PTO Guard anchor chain to the anchor loop on the spreader hitch.
9. Place the PTO storage chain back in the slotted storage bracket so it does not dangle.
10. Remove wheel chocks.

⚠ WARNING NEVER OPERATE SPREADER WITH ANY GUARDS OR SHIELDS REMOVED. FAILURE TO HEED MAY RESULT IN SERIOUS PERSONAL INJURY OR DEATH.

⚠ WARNING SPREADER MUST BE HITCHED TO TRACTOR FOR LOADING. THE JACK CAN NOT SUPPORT THE LOADED SPREADER WEIGHT AND/OR UNEXPECTED "TIP UP" OF THE SPREADER CAN RESULT.

LOADING

1. Park the spreader for loading. Put the tractor in PARK or NEUTRAL and apply the parking brake.
2. Close the hydraulic rear gate before loading.
3. It is unlawful to allow any manure spillage to occur on public roadways. Be sure rear gate is fully closed and sliding gate scrapers are adjusted so no liquid leakage occurs. Do not heap load such that manure is allowed to fall off spreader during transporting on roadways.
4. Load the spreader. The moisture content will determine how full it can be loaded. See SPECIFICATIONS for capacity. Solid manure can generally be loaded level to slightly heaped. High moisture slurries are heavier and loading may be limited.

UNLOADING

1. Engage the tractor PTO to start the beaters and increase engine speed to 1000 PTO RPM.

⚠ WARNING KEEP AWAY AND KEEP OTHERS AWAY FROM THE ROTATING BEATERS. BEATERS CAN CRUSH, DISMEMBER OR KILL.

⚠ WARNING CLEAR THE AREA OF ALL PERSONS BEFORE BEGINNING OPERATION.



2. Raise the hydraulic rear gate completely up. See figure 5.
3. Start the sliding gate.
4. When material begins discharging from the beaters, begin forward motion.
5. Plan application onto the field so that you do not travel over previously spread manure which

NOTE: Performing the preceding steps while moving forward will minimize heavy discharge onto the field during startup.

is slippery. Travel cautiously on hills and slopes. Proceed up and down slopes instead of along them.

SHUT DOWN

1. When the load has been discharged, the hydraulic control to the sliding gate will return to neutral, OFF. Allow the beaters to operate for a few seconds to clear out any remaining material and then stop the PTO.
2. Start the sliding gate to return to the front of the spreader. When it reaches the front the hydraulic control to the sliding gate will return to neutral, OFF.
3. Once the sliding gate moves forward enough to clear the rear gate, completely close the rear gate.

UNHOOK THE TRACTOR

1. Park the spreader on level ground. Put the tractor in PARK, set the park brake, and turn the engine off before dismounting.
2. Place wheel chocks in front and in back of two spreader wheels on opposite sides to prevent the spreader from rolling after the tractor is unhooked.
3. Remove the PTO drive shaft yoke from the splined tractor PTO shaft. Unhook the PTO storage chain from the slotted storage bracket and pivot the PTO drive shaft up and into the storage bracket. Reconnect the storage chain in the slotted storage bracket to secure the PTO shaft.
4. Remove the hydraulic hose ends from the tractor hydraulic ports and store the hose ends in the slotted hose storage brackets to keep them from dragging on the ground. See figure 4.
5. Crank the spreader jack down until the spreader hitch lifts off the tractor draw bar.
6. Remove the hitch pin.
7. Unhook safety chain from tractor drawbar support. See figure 4.
8. Slowly drive the tractor away from the spreader.

STORAGE AND CLEANING

DISCONNECT PTO DRIVE SHAFT AND HYDRAULIC HOSES BEFORE CLEANING, ADJUSTING, LUBRICATING, OR SERVICING THIS MACHINE.

1. The spreader must be thoroughly cleaned periodically, especially if stored for extended periods. Manure is acidic and will

⚠ WARNING TURN OFF ALL POWER DURING CLEANING AND INSPECTION. DO NOT USE POWER TO MOVE ANY COMPONENTS OR TO DISCHARGE MATERIAL WHILE CLEANING OR INSPECTING.

damage paint and cause rusting of metal components.

2. Allow the spreader to completely unload.
3. Return the sliding gate to the front of the spreader.
4. To clean the spreader, raise the rear gate.
5. Hose off manure from the outside and inside of the spreader. Completely clean manure from moving mechanisms such as the beaters, winged pulley, sliding gate, chain drive and rear gate. Remove accumulation in confined areas or pockets that trap manure.
6. Avoid directing high pressure spray directly on bearings, seals and flow control valve.
7. Keep high pressure spray moving on painted surfaces. Sustained spray on cracks or scratches in paint can result in paint peeling.
8. Allow machine to dry.
9. Lower rear gate completely down before storing spreader.
10. Inspect the spreader for loose connections, damaged hydraulic hoses or connections and for other damaged components. Repair if necessary so the spreader is ready for future operation.

MAINTENANCE

⚠ WARNING PUT THE TRACTOR IN PARK, APPLY THE PARKING BRAKE, TURN OFF ENGINE AND REMOVE IGNITION KEY BEFORE CLEANING, ADJUSTING, LUBRICATING OR SERVICING THIS MACHINE. FAILURE TO HEED MAY RESULT IN SERIOUS PERSONAL INJURY OR DEATH.

⚠ WARNING DISCONNECT PTO DRIVE SHAFT AND HYDRAULIC HOSES BEFORE CLEANING, ADJUSTING, LUBRICATING, OR SERVICING THIS MACHINE.

READ THE FOLLOWING BEFORE WELDING ON THIS MACHINE

1. When welding on your spreader, do not allow the current to flow through the ball bearings or the roller chains. Ground directly to the item being welded.
2. The alternator should always be disconnected if the spreader is not disconnected from the towing vehicle.

LUBRICATION

Bearings

Grease 2 lower beater bearings and 2 belt pulley bearings every 100 hours of operation with 2 pumps of grease. See figure 6.

PTO DRIVE SHAFT

1. The PTO drive shaft yoke cross bearings must be greased, both ends of assembly. Grease every 8 hrs of operation with one pump. See figure 6.
2. There is also a zerk at the center of the shaft assembly to grease the telescoping shafts. It is accessible through a slot in the guard. Grease every 8 hrs of operation with 4 pumps. See figure 6.

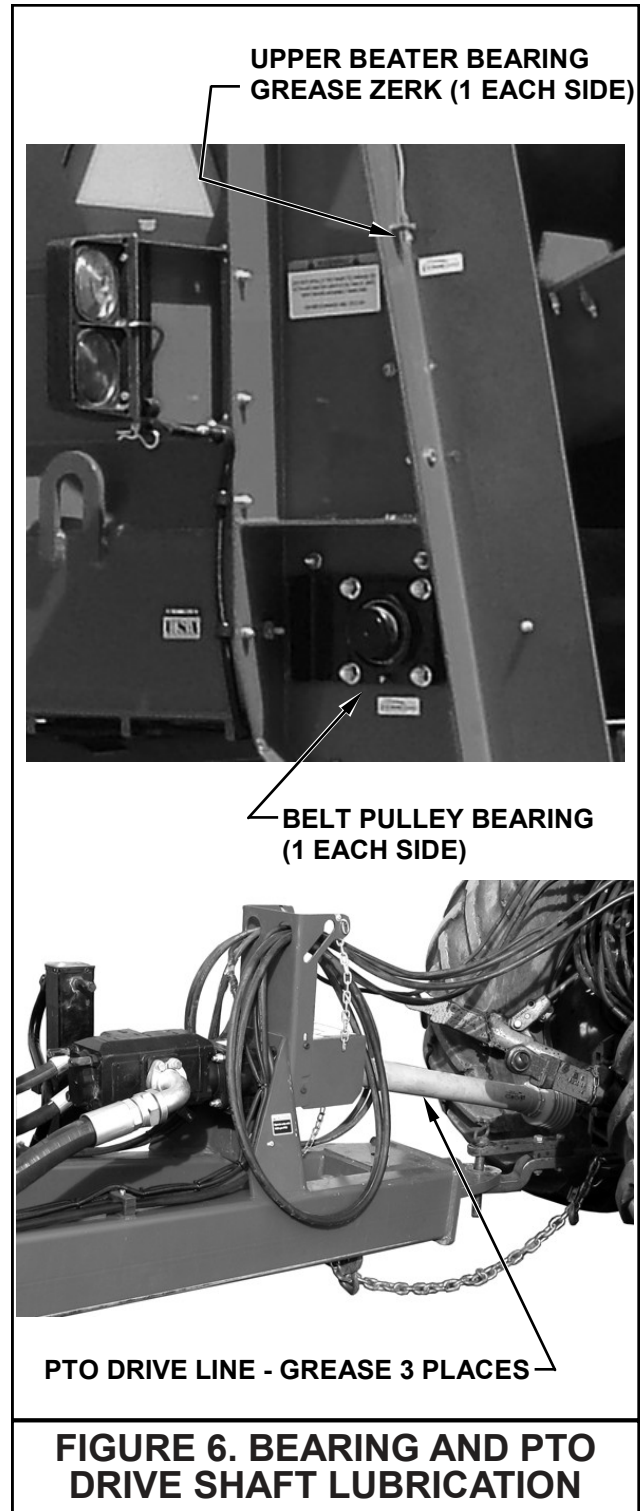

DRIVE CHAIN PLANETARY GEARBOX

(See figure 7)

Oil Specification: (Mobil Delvac Synthetic Gear Oil 75W-90) .

There is a check plug half way up on the gearbox. Maintain the oil level to this check plug. Fill plug is located on the top of the gearbox.

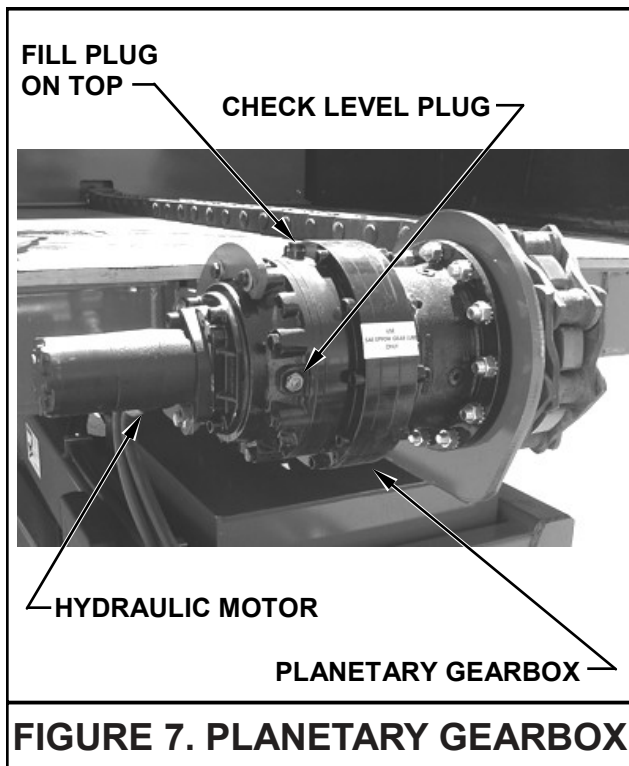

WHEEL HUBS

Check oil lever in wheel hubs every 8 hours of operation. Bring up to full line if they are low, use 90w gear lube.

HYDRAULIC SYSTEM

(See figure 8)

1. Oil Specification: (CITGO TRANSGARD TRACTOR HYDRAULIC FLUID) - Material Code 633310001) .
2. Capacity: 40 gallon
3. Maximum allowable operating temperature 240° F.
4. Check the oil level in the reservoir daily. It

should be maintained 1" from the top level on the sight gauge.

5. Oil is added through a filter screen inside the filler neck. Before filling, remove the screen, inspect and clean if required.
6. Carefully clean dirt from the return filter head and element. Replace the filter element every 500 hrs of operation.
7. Drain reservoir and refill with new oil every 2000 hrs or annually, whichever occurs first. If the oil becomes contaminated and appears milky colored, replace immediately.
8. Every 100 hrs of operation, inspect all hydraulic hoses, hose connections, pump seals and motor seals for leakage. Tighten loose connections and replace damaged components.
9. A ball valve is provided at the bottom of the reservoir where the suction hose is connected. Turn this valve off to service hydraulic components. This prevents draining of the reservoir, however it is necessary to catch the oil that drains from disconnected hoses into a suitable container for proper disposal. Always check and refill the reservoir as required when servicing is completed.

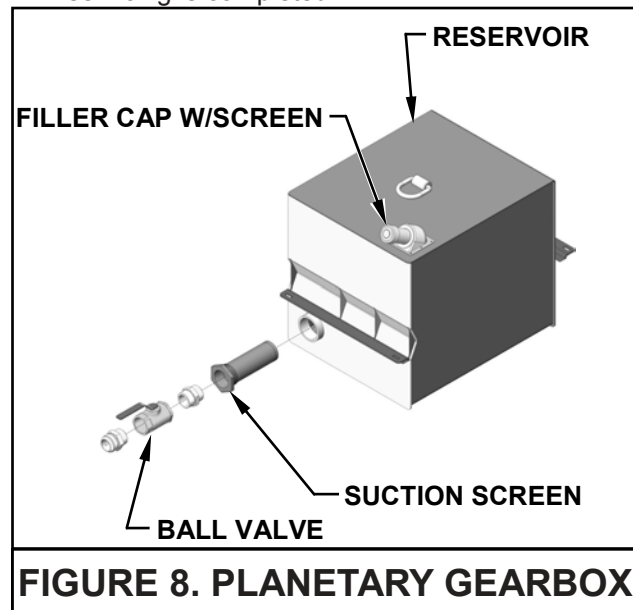

REAR GATE FLASHING

(See figure 9)

1. Swinging gate flashing strips are clamped to both vertical ends of the rear gate frame. These strips must bear against the vertical box sides to minimize leakage.

2. To adjust, loosen the six 3/8" carriage bolts clamping the flashing.
3. Move the flashing strips so they contact against the box wall and retighten bolts.

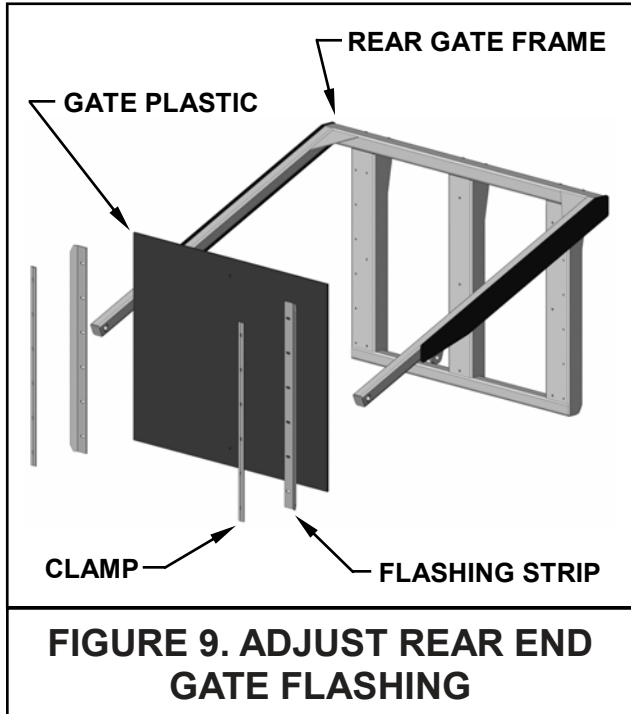

FIGURE 9. ADJUST REAR END GATE FLASHING

ADJUSTMENTS

SLIDING GATE SCRAPERS

(See figure 10)

1. A high density polyethylene scraper bar is clamped to the vertical edges of the sliding gate. These scrapers must contact the vertical box walls to clean material.
2. To adjust, loosen the seven 3/8" bolts clamping the scraper.
3. Move the scrapers so they contact against the box wall and retighten bolts.

DRIVE CHAIN SLACK

(See figure 11)

1. To adjust the floor drive chain, run the sliding gate all the way to the rear of the spreader, (discharge end), until it stops.
2. Remove the front panel of the sliding gate.
3. A threaded adjuster rod is provided where the

drive chain attaches to the sliding gate. It is factory preset, but may require adjustment with usage.

4. Loosen the two 7/8" hex nuts on the end of the threaded rod. Tighten the inner nut until the large flat washer is 7/8" from the stop. Tighten the outer nut against the inner to lock the adjustment.
5. Replace front panel.

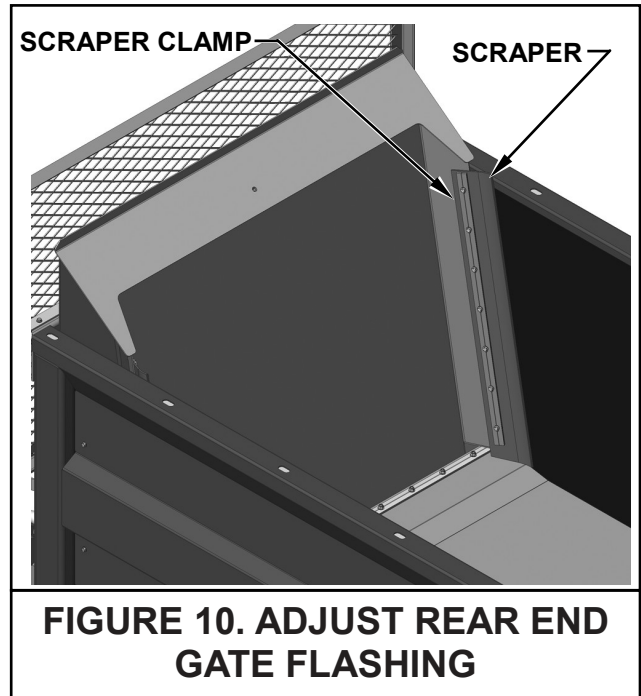

FIGURE 10. ADJUST REAR END GATE FLASHING

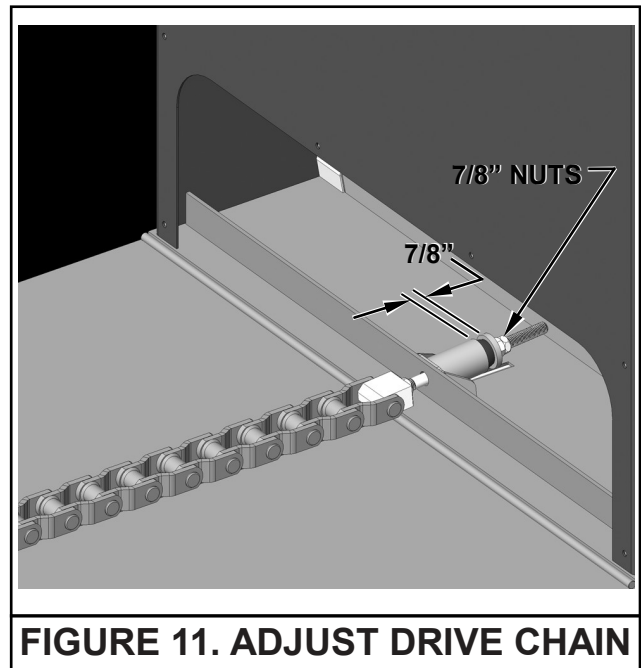
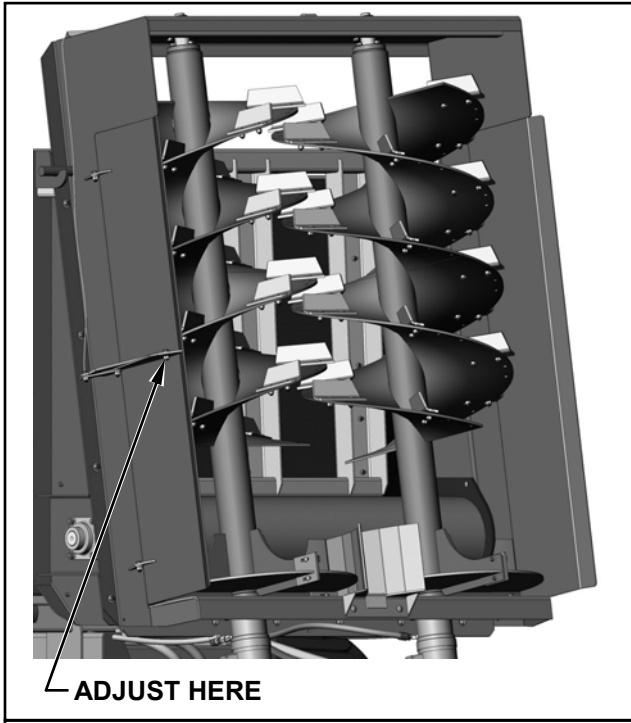

FIGURE 11. ADJUST DRIVE CHAIN



**FIGURE 12. ADJUST
SPREAD PATTERN**

532-16B SPREADER

REPAIR PARTS TABLE OF CONTENTS

DESCRIPTION	PAGE NO.
Spreader Assembly.....	24
Spreader Box Assembly.....	26
Trailer Spreader Sides	28
Trailer Assembly	3
Trailer Hub & Wheel Assembly	32
Beater Assembly	34
Sliding Gate Assembly	36
Rear Gate Assembly	37
Decals	38
PTO Drive Shaft Assembly.....	39
Hydraulic Pump	40
Hydraulic Tank & Chain Motor	41
Hydraulic Valve Block & Fittings.....	42-43
Hydraulic Cylinders—Rear Gate	44
Beater Motor Hydraulics.....	45
Manifold Valve Assembly	46
Wiring Schematic	47

532-16B SPREADER TRAILER ASSEMBLY

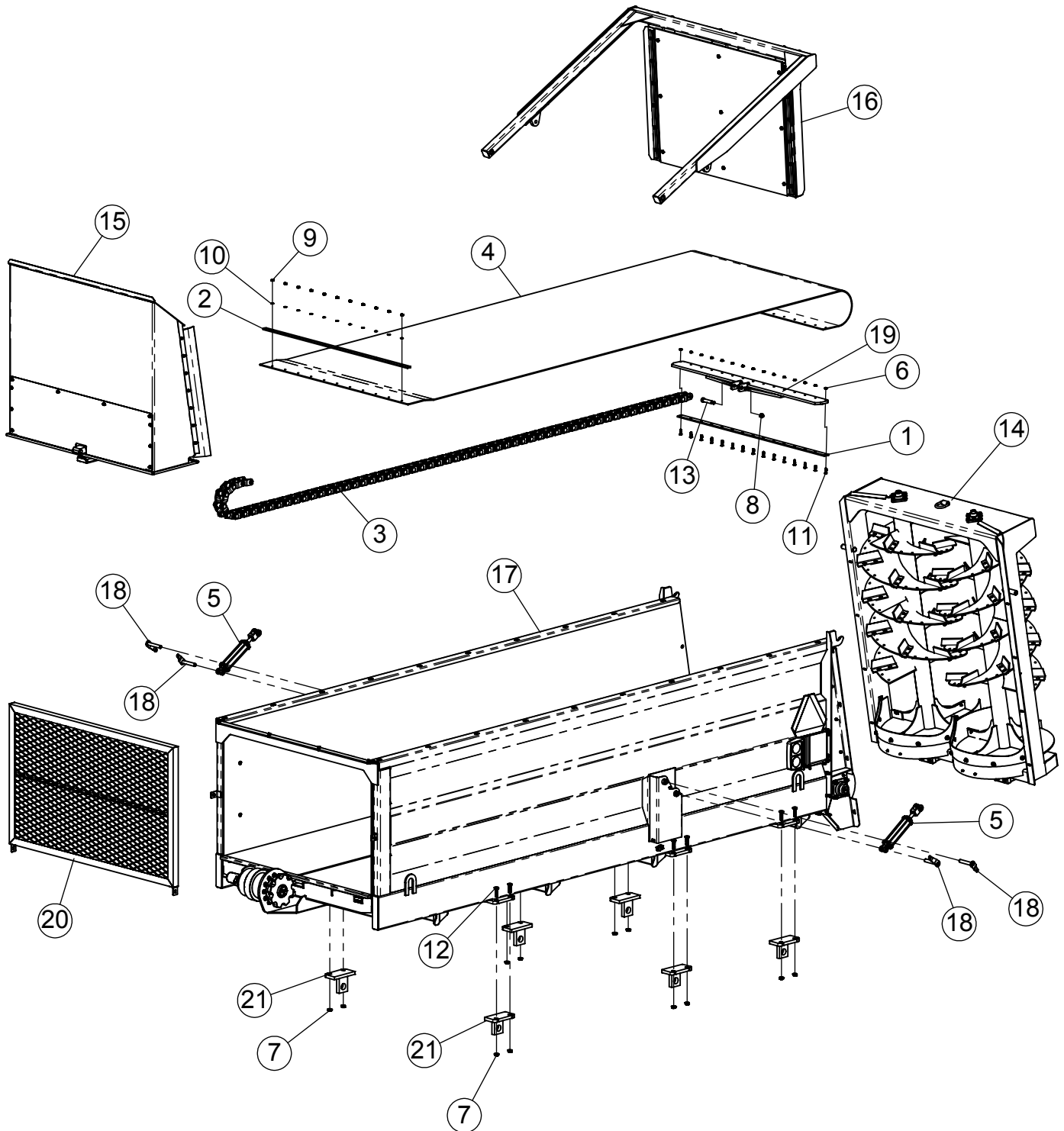

532-16B SPREADER TRAILER ASSEMBLY

ITEM #	PART #	DESCRIPTION	QTY.
1	130445	PLATE BELT CLAMP	1
2	131214	BELT CLAMP	1
3	322561	CHAIN, WELDED MILL-4.063 PITCH - (20' 8" LG)	1
4	351033	532 BELT, 5/16" x 71-1/2" x 235" LG	1
5	364073	HYDRAULIC CYLINDER 2-1/2" x 8" x 20-1/4"	2
6	400107	SERRATED FLANGE HEX NUT, 3/8"-16	23
7	400116	SERRATED FLANGE HEX NUT, 3/4-10 #5 PLTD	12
8	401112	HEX NYLOC NUT 3/4"-10 #5 PLTD	1
9	401207	HEX NYLOC NUT 7/16" -20 #5 Pltd	11
10	402507	FLAT WASHER 7/16" SAE	11
11	407043	CHCS 3/8"-16 x 1 3/4" #5 PLTD	15
12	407142	CHCS 3/4" x 3" #5 PLTD	12
13	407414	SHOULDER BOLT, 1"D x 4" LG x 3/4-10 THD.	1
14	730171	532B/672 BEATER ASSEMBLY	1
15	730174	532B/672 SLIDING GATE ASSEMBLY	1
16	730175	532B REAR GATE ASSEMBLY	1
17	730179	532B SPREADER BOX SUB ASSEMBLY, TRAILER	1
18	830235	802 PIVOT PIN W/A	4
19	830339	CHAIN / BELT ADAPTER W/A	1
20	830352	532/672 SPREADER SCREEN W/A	1
21	830373	WEIGH BAR MOUNT W/A, 2-1/2"	6

532-16B SPREADER TRAILER BOX ASSEMBLY

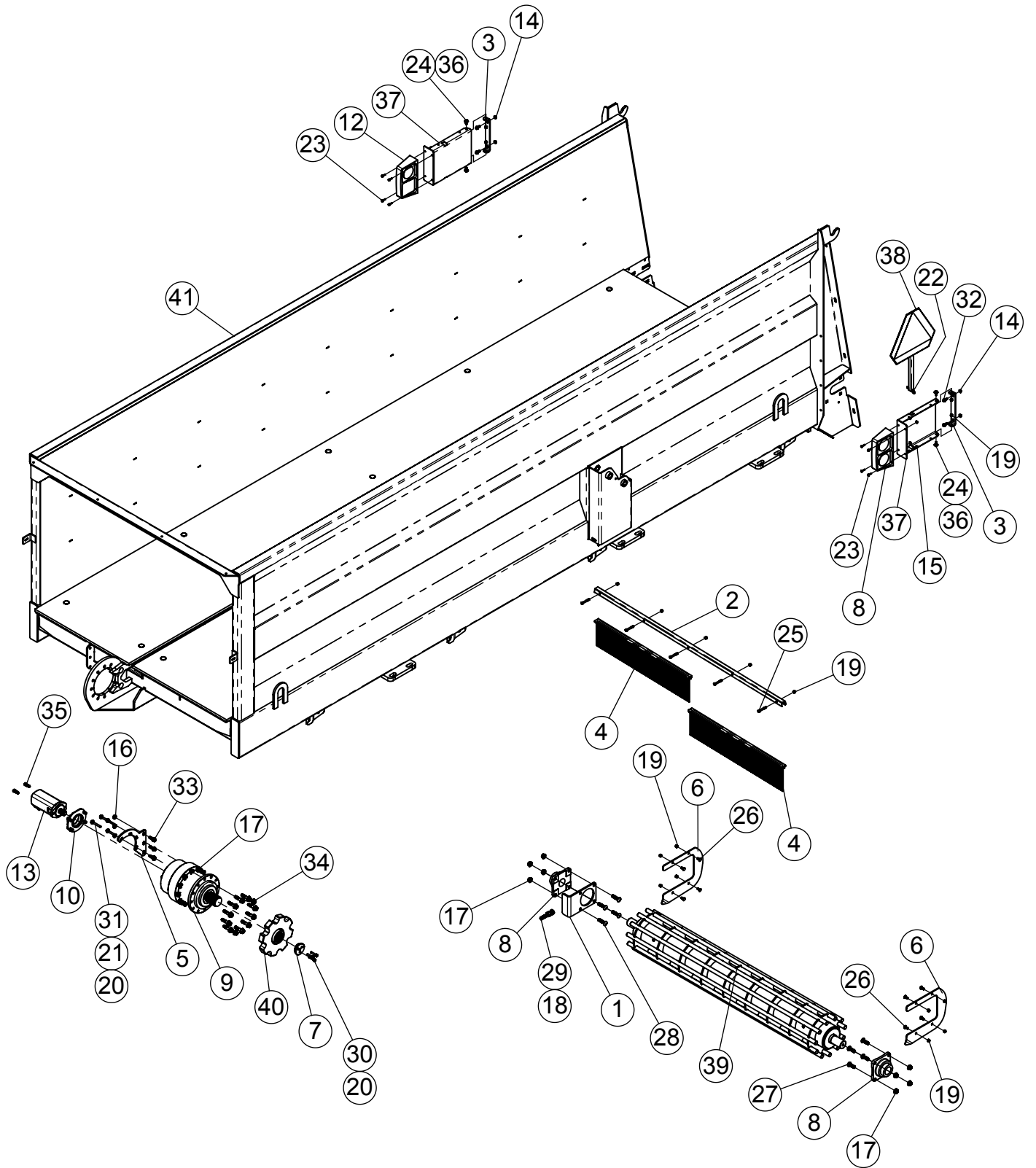

532-16B SPREADER TRIALER BOX ASSEMBLY

ITEM #	PART #	DESCRIPTION	QTY.
1	130316	BRACKET, BELT ADJUSTER	1
2	130446	BROOM CLAMP	1
3	130820	HAZARD LIGHT MOUNTING BRACKET	2
4	130837	BROOM, 8" BRISTLES	2
5	131068	GEARBOX SUPPORT	1
6	131611	SPACER, BELT	2
7	332680	COVER, SPLINED SHAFT	1
8	340436	BEARING 2 3/16" FAFNIR	2
9	344136	GEAR BOX, 25.98:1 REDUCTION	1
10	344274	FLANGE KIT, BREVINI SAE/A/ CS 14T IMP.	1
8	357512	LIGHT ASSEMBLY, LEFT HAND	1
12	357513	LIGHT ASSEMBLY, RIGHT HAND	1
13	360049	HYD MOTOR, 18.7 CIR 14 TOOTH "A" MNT	1
14	400107	HEX NUT, 3/8"-16 SERRATED FLANGE #5	4
15	400113	FLANGE HEX NUT, 1/4"-20 SERRATED	8
16	400114	SERRATED FLANGE HEX NUT 1/2"-13 #5 PLTD	3
17	400115	HEX NUT, 5/8"-11 SER. FLANGE #5 PLTD	20
18	400812	HEX NUT, 3/4"-10 CENTER-LOC #5 PLTD	1
19	401106	HEX NYLOC NUT, 3/8"-16 #5 PLTD	39
20	402006	WASHER SPRING LOCK 3/8" MED PLTD	7
21	402406	FLAT WASHER 3/8" PLTD	4
22	404210	CLIPP PIN 5/32" x 2.94 # 10	1
23	405604	HHCS 1/4"-20 x 1" #5 PLTD	8
24	405653	HHCS 3/8"-16 x 1" #5 PLTD	4
25	405659	HHCS 3/8-16 x 2-1/2 #5 PLTD	5
26	407040	CHCS 3/8"-16 x 1" #5 PLTD	8
27	407121	CHCS 5/8"-11 x 2" #5 PLTD	4
28	407122	CHCS 5/8"-11 x 2-1/2" #5 Pltd	4
29	407475	HHCS 3/4"-10 x 4" #5 PLTD FULL THREAD	1
30	407810	HHCS 8.8 - 10MM x 50MM	3
31	407818	HHCS METRIC 10mm-1.5 x 80mm (GRD 10.9)	4
32	407901	HHCS 3/8"-16 X 1" SERRATED #5 PLTD	4
33	407913	HHCS 1/2"-13 x 1-1/2" SERRATED #5 PLTD	3
34	407924	HHCS 5/8"-11 x 2-1/2" SERRATED #5 PLTD	12
35	409063	SHCS, 1/2"-13 x 1-1/4" LG	2
36	410029	BELLVILLE DISC SPRING, 1" OD x .406 ID x .106THICK	4
37	830318	HAZARD LIGHT MOUNTING BRACKET W.A.	2
38	830319	362/532/672 SLOW SIGN BRACKET W.A.	1
39	830343	532/672 BELT PULLEY W/A	1
40	830344	532B SPROCKET W/A, SPREADER	1
41	830400	532B SPREADER BOX W/A	1

532-16B SPREADER TRAILER

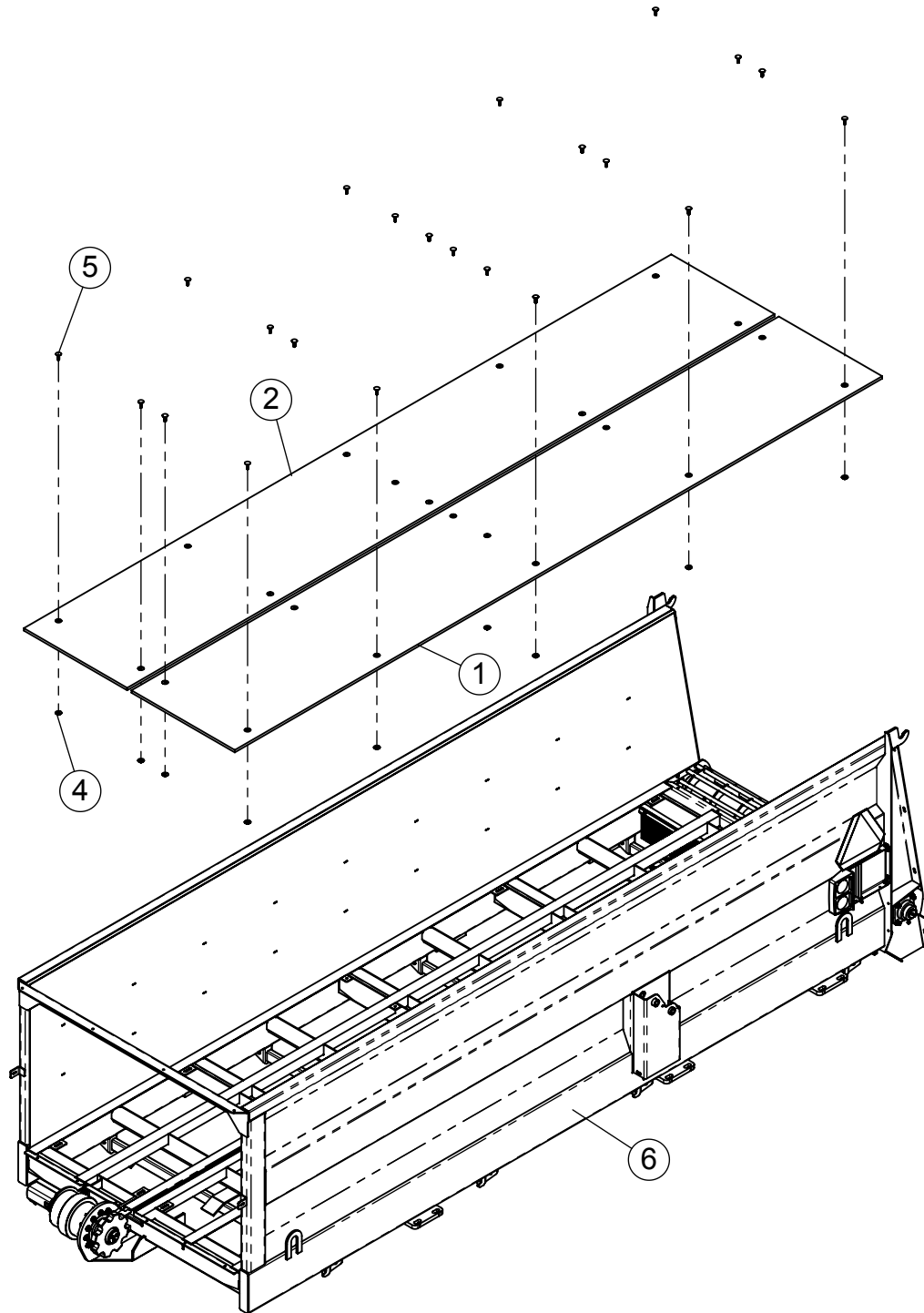

ITEM #	PART #	DESCRIPTION	QTY.
1	131615	532B FLOOR, 1/2" HDPE-UVI	1
2	131616	532B FLOOR, R/H, 1/2" HDPE-UVI	1
3	401106	HEX NYLOC NUT, 3/8"-16 #5 PLTD	22
4	402606	FENDER WASHER 3/8" x 1 1/2" PLTD	22
5	407325	ELEVATOR BOLT PLTD 3/8"-16 x 1-3/4"	22
6	830400	532B SPREADER BOX W/A	1

This page intentionally left blank.

532-16B TRAILER ASSEMBLY

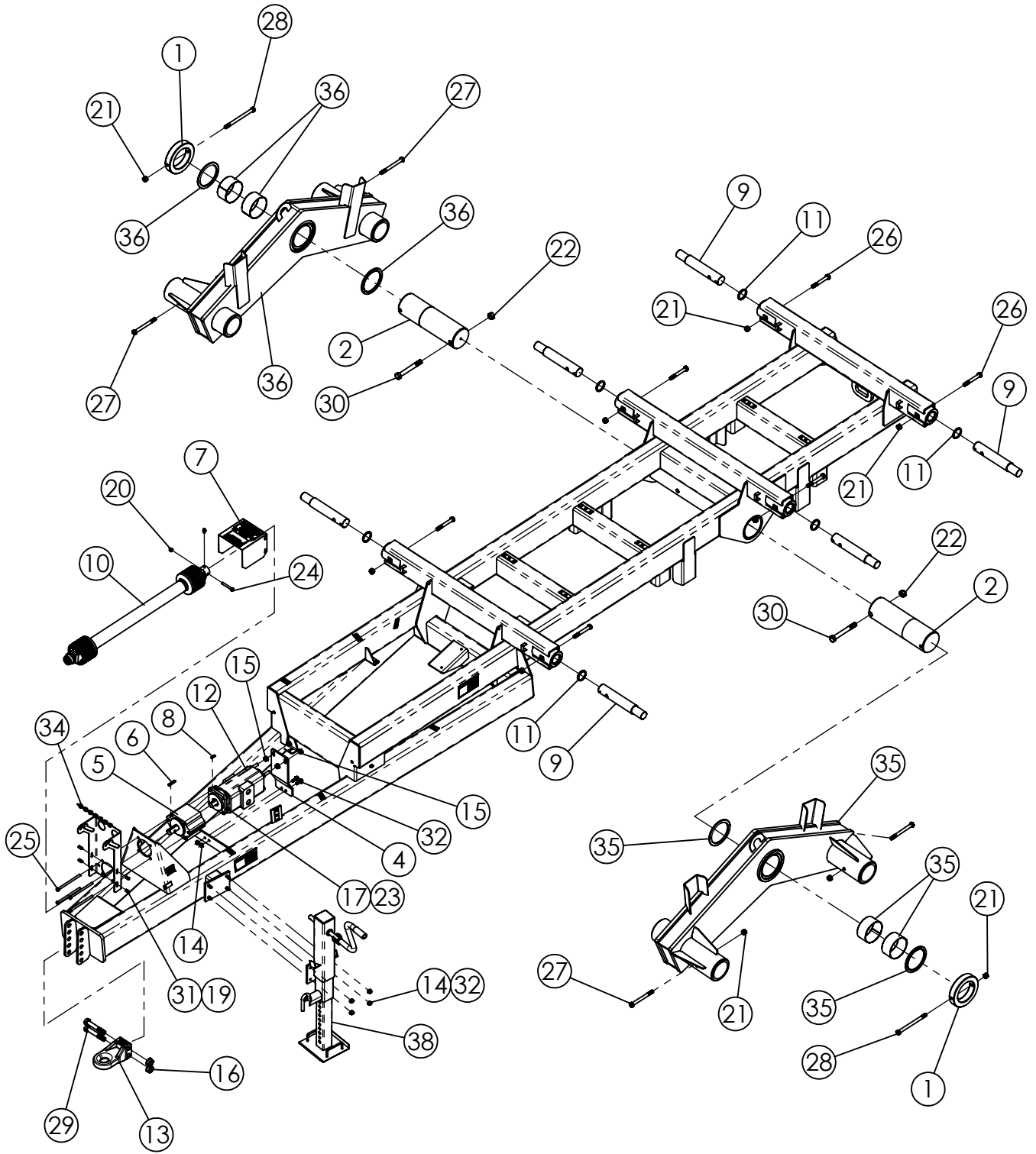

532-16B TRAILER ASSEMBLY

ITEM #	PART #	DESCRIPTION	QTY.
1	130858	AXLE RETAINER	2
2	130868	AXLE WALKING BEAM PIVOT	2
3	130916	PTO SHIELD MOUNT BRACKET	1
4	131260	PLATE, PUMP	1
5	131269	OVERHUNG ADAPTER, 1.5 x 1.25B, DRILLED	1
6	140954	KEY 3/8" SQ. X 2-1/4"	1
7	185302	P.T.O. SHIELD 9" x 22 9/16"	1
8	185483	KEY 5/16" SQ x 1-1/4" LG.	1
9	189244	DUMMY WEIGH BAR 2 1/2" W/HOLE	6
10	338027	DRIVE SHAFT W2400 1-3/4" 20T x 1 1/2" D. KEY	1
11	355041	SEAL, 3 OD x 2-1/2 ID x 1/4"	6
12	362030	PUMP ASSY, 7.2 CIR (PERMCO)	1
13	374114	BALL HITCH, CAT. 4, 2" PIN	1
14	400114	SERRATED FLANGE HEX NUT 1/2"-13 #5 PLTD	6
15	400115	SERRATED FLANGE HEX NUT 5/8"-11 #5 PLTD	4
16	400117	FLANGE HEX NUT 1"-8 SERRATED	2
17	400208	HEX NUT 1/2"-13 #5 PLTD	4
18	400606	HEX JAM NUT 3/8-16"	1
19	401105	HEX NUT, 5/16"-18 NYLOC #5 PLTD	4
20	401108	HEX NYLOC NUT 1/2"-13 #5 PLTD	1
21	401112	HEX NUT, 3/4"-10 NYLOC #5 PLTD	12
22	401216	HEX NYLOC NUT 1"-8 #5 PLTD	2
23	402008	SPRING LOCK WASHER 1/2" PLTD	4
24	405711	HHCS 1/2"-13 x 3-1/2" #5 PLTD	1
25	405720	HHCS 1/2"-13 x 8" #5 PLTD	4
26	405790	HHCS 3/4"-10 x 5-1/2" #5 PLTD	6
27	405794	HHCS 3/4"-10 x 7-1/2" #5 PLTD	4
28	405797	HHCS 3/4"-10 x 10" #5 PLTD	2
29	405837	HHCS 1" x 6" #5 PLTD	2
30	405841	HHCS 1" x 8" #5 PLTD	2
31	407410	SHOULDER BOLT 3/8" x 3/8" LG x 5/16" THD	4
32	407913	HHCS 1/2"-13 x 1-1/2" SERRATED #5 PLTD	6
33	409543	SQ HD SET SCREW CUP, 3/8" x 1"	1
34	412020	CHAIN-2/0 PASSING LINK	1
35	730166	WALKING BEAM ASSY, L/H	1
36	730167	WALKING BEAM ASSY, R/H	1
37	830360	532 TRAILER (2ND GEN)	1
38	872090	DROP LEG JACK 9T	1

532-16B TRAILER HUB & WHEEL ASSEMBLY

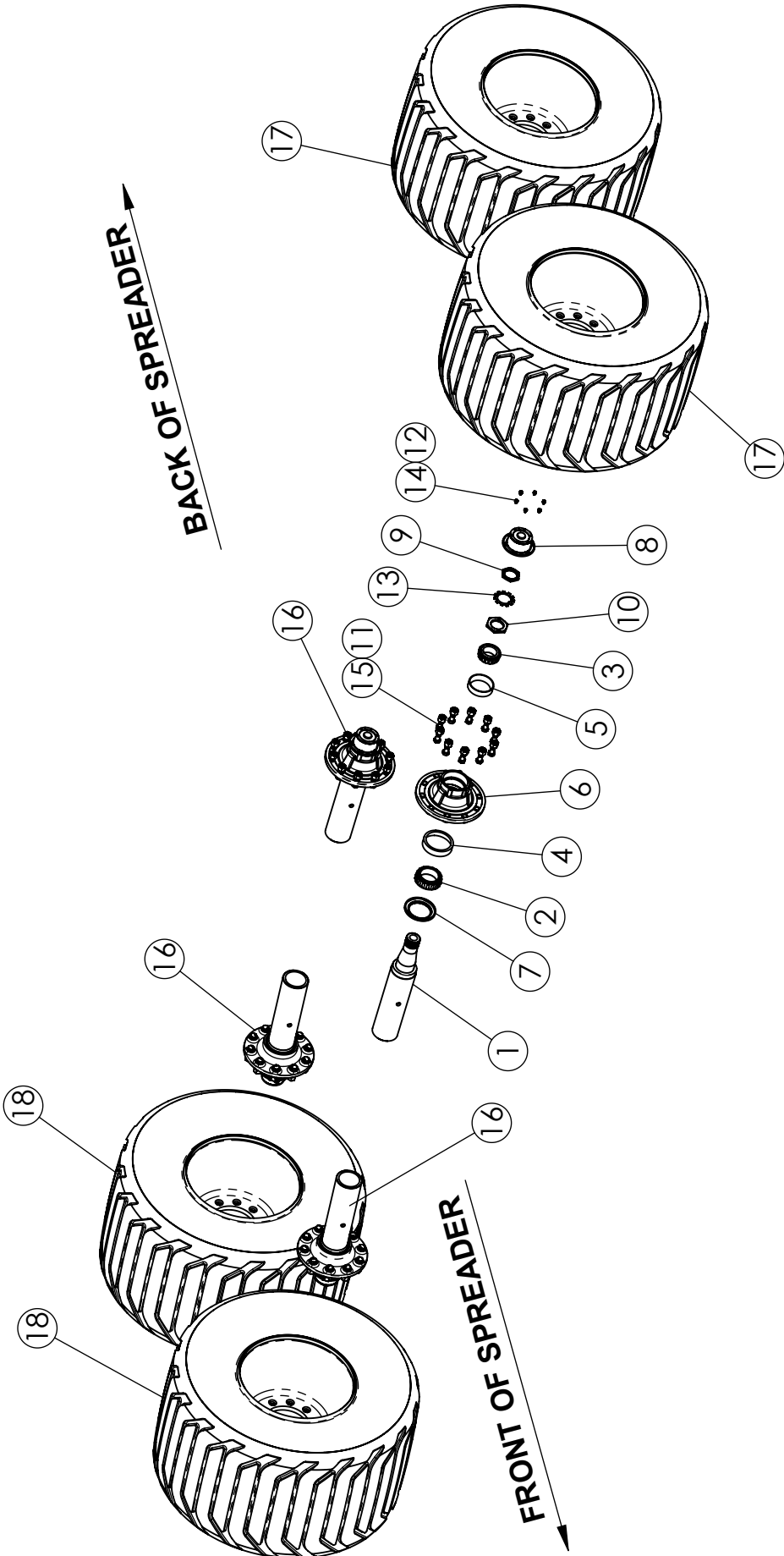

532-16B TRAILER HUB & WHEEL ASSEMBLY

ITEM #	PART #	DESCRIPTION	QTY.
1	190520	SPINDLE, 20,000# - SPREADER	1
2	342213	INNER BEARING 3.543" BORE, HM218248	1
3	342214	OUTSIDE BEARING 2 5/8" OD, HM212049	1
4	342215	INNER BEARING RACE 5.787"OD, HM218210	1
5	342216	OUTSIDE BEARING RACE 4 13/16 OD, HM212011	1
6	372212	10-BOLT HUB, 20,000#	1
7	372304	SEAL 4 3/8" BORE, STEMCO #372-7097	1
8	372309	DUST CAP, 20,000# HUB, STEMCO 343-4009	1
9	400033	OUTER NUT, 3/8" THICK x 2 5/8" ID	1
10	400034	INNER NUT, 3/8" THICK x 2 5/8" ID	1
11	400102	LUG Nut, Budd RH 3/4-16	10
12	402005	WASHER SPRING LOCK 5/16" MED PLTD	6
13	402904	LOCKING WASHER 1/4" THICK x 2 41/64" ID	1
14	405625	HHCS 5/16" x 1/2" #5 Pltd	6
15	407728	STUD BOLT 3/4" x 2 9/16"	10
16	750109	TRAILER HUB ASSY, RH 20K, SPREADER	4
17	780968L	24 x 22.5 WHL/TR ASSY (700/40-22.5 H/D FLOAT) LT	2
18	780968R	24 x 22.5 WHL/TR ASSY (700/40-22.5 H/D FLOAT) RT	2

532-16B SPREADER BEATER ASSEMBLY

Used on all spreaders with serial number 410300311 and previous.

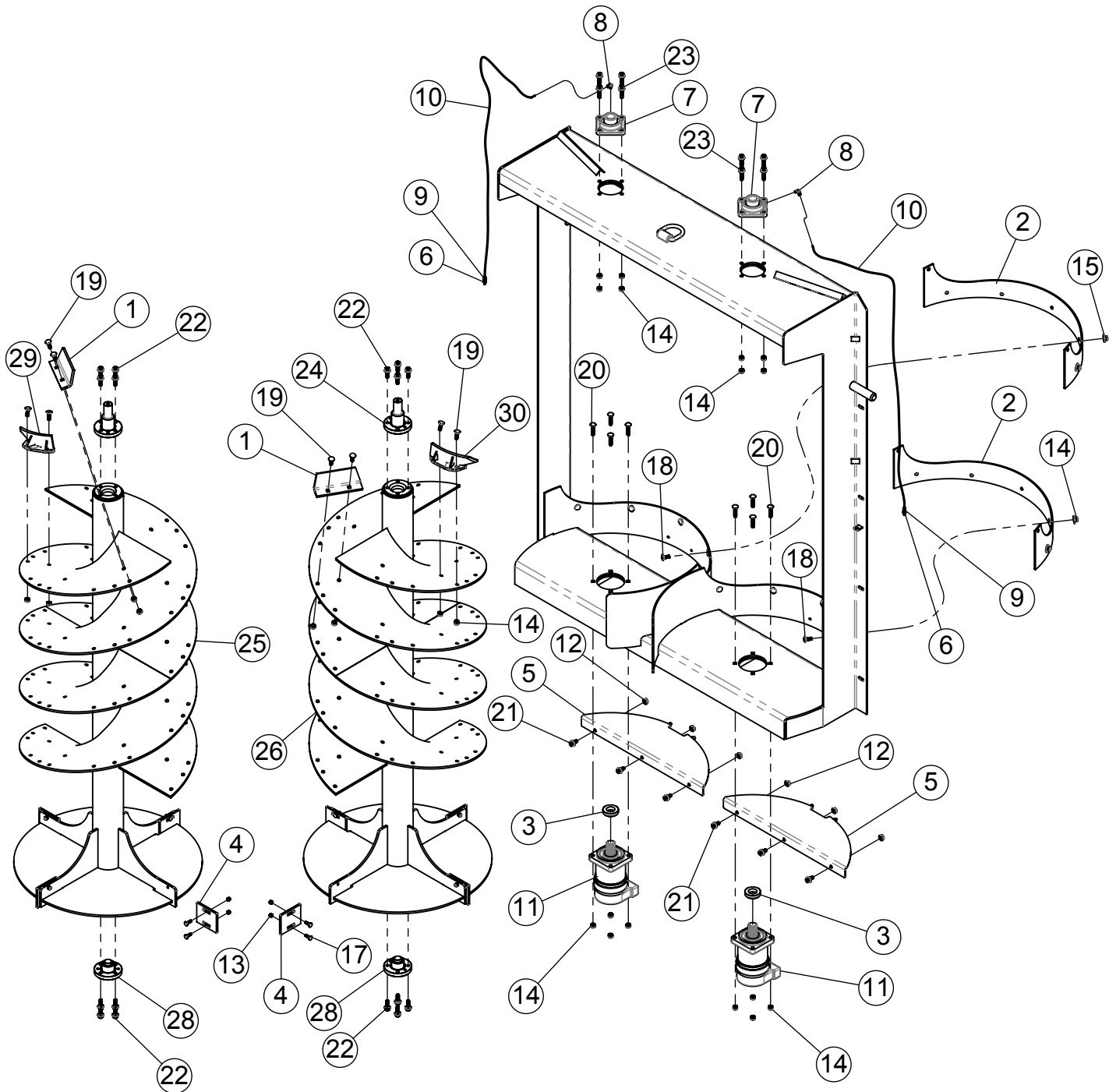

532-16A SPREADER BEATER ASSEMBLY

Used on all spreaders with serial number 410300311 and previous.

ITEM #	PART #	DESCRIPTION	QTY.
1	130464	ANGLE DEFLECTOR	2
2	130546	532 SKIRT, FLEXIBLE RUBBER	2
3	130748	802 BEATER MOTOR SPACER (5/8" LG)	2
4	130829	802 PADDLE WEAR PLATE	8
5	130905	SKIRT SUPPORT PLATE (REMOVABLE)	2
6	310750	GREASE ZERK PLTD 1/8"	2
7	340425	BEARING, 1-1/2" ,RCJ 4-BOLT FLANGE,(ECCENTRIC)	2
8	356001	COMPRESSION FITTING 1/8"MP x 3/16", 90°	2
9	356002	COMPRESSION FITTING 1/8" MP x 3/16" STRAIGHT	2
10	356203	GREASE LINE, 3/16 x 70" LG	2
11	360045	HYDRAULIC MOTOR 24.4 CIR VIS	2
12	400114	SERRATED FLANGE HEX NUT 1/2"-13 #5 PLTD	6
13	401106	HEX NYLOC NUT, 3/8"-16 #5 PLTD	20
14	401108	HEX NYLOC NUT 1/2"-13 #5 PLTD	37
15	402408	FLAT WASHER 1/2" MED PLTD	10
16	405653	HHCS 3/8"-16 x 1" #5 PLTD	4
17	407041	CHCS 3/8"-16 X 1-1/4" #5 PLTD	16
18	407101	CHCS 1/2"-13 X 1-1/4" #5 PLTD	10
19	407102	CHCS 1/2"-13 x 1-1/2" #5 PLTD	8
20	407105	CHCS 1/2"-13 x 2-1/4" #5 PLTD	8
21	407911	HHCS SERRATED 1/2"-13 x 1" #5 PLTD	6
22	407913	HHCS SERRATED 1/2"-13 x 1-1/2" #5 PLTD	16
23	407915	HHCS SERRATED 1/2"-13 x 2" #5 PLTD	8
24	830301	802 BEATER IDLER SHAFT W/A	2
25	830353	532B/672 LEFT VERTICAL BEATER W/A	1
26	830354	532B/672 RIGHT VERTICAL BEATER W/A	1
27	830387	532B FRAME W/A, VERTICAL BEATER	1
28	830388	DRIVE FLANGE W/A 532B	2
29	830333	532/672 L/H CHISEL POINT DEFLECTOR W/A	1
30	830334	532/672 R/H CHISEL POINT DEFLECTOR W/A	1

532-16B SPREADER HEAVY BEATER ASSEMBLY

Used on spreaders with serial number 410200312 to present.

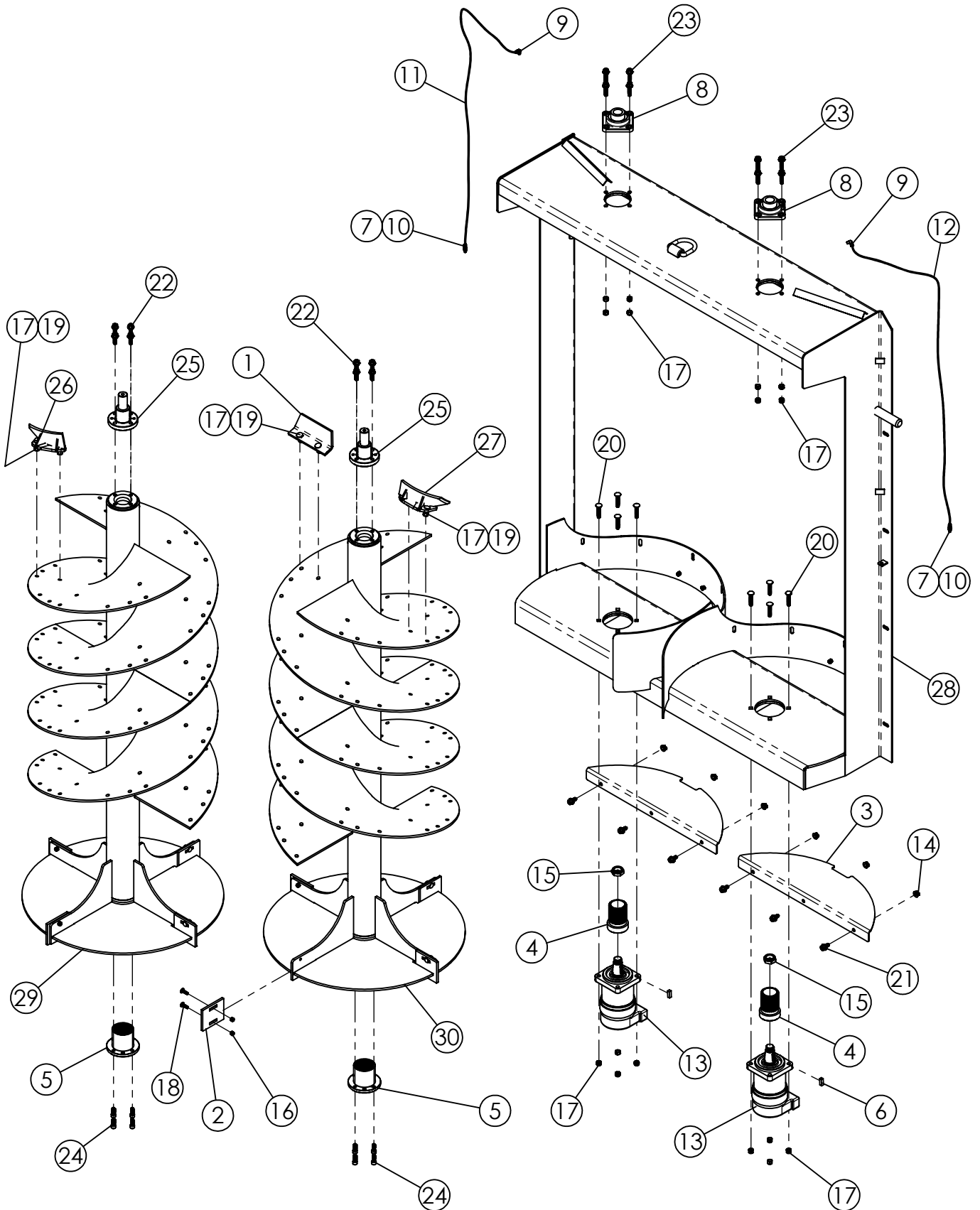

532-16B SPREADER HEAVY BEATER ASSEMBLY

Used on spreaders with serial number 410200311 to present.

ITEM #	PART #	DESCRIPTION	QTY.
1	130464	ANGLE DEFLECTOR 9" x 4-1/2"	AN
2	130829	802 PADDLE WEAR PLATE	8
3	130905	SKIRT SUPPORT PLATE (REMOVABLE)	2
4	131205	SPLINED ADAPTER, (BEATER DRIVE)	2
5	131208	SPLINED HUB (BEATER DRIVE)	2
6	131262	KEY, 7/16" SQUARE x 1-1/4" LG.	2
7	310750	GREASE ZERK PLTD 1/8"	2
8	340425	BEARING, 1-1/2" ,RCJ 4-BOLT FLANGE,(ECCENTRIC)	2
9	356001	COMPRESSION FITTING 1/8"MP x 3/16", 90°	2
10	356002	COMPRESSION FITTING 1/8" MP x 3/16" STRAIGHT	2
11	356203	GREASE LINE, 3/16" x 70" LG	1
12	356203	GREASE LINE, 3/16" x 70" LG	1
13	360047	HYD MOTOR	2
14	400114	FLANGE HEX NUT, 1/2"-13 SERRATED	6
15	400145	HEX NUT, THIN 1-1/4-18 UNEF THD (EXTRA FINE)	2
16	401106	HEX NUT, 3/8"-16 NYLOC #5 PLTD	16
17	401108	HEX NUT, 1/2"-13 NYLOC #5 PLTD	AN
18	407041	CHCS, 3/8"-16 X 1-1/4" #5 PLTD	16
19	407102	CHCS 1/2"-13 x 1-1/2" #5 PLTD	AN
20	407106	CARRIAGE BOLT, 1/2"-13 x 2-1/2" LG	8
21	407911	HHCS SERRATED 1/2"-13 x 1" #5 PLTD	6
22	407913	HHCS 1/2"-13 x 1-1/2" SERRATED #5 PLTD	8
23	407915	HHCS SERRATED 1/2"-13 x 2" #5 PLTD	8
24	409063	SHCS, 1/2"-13 x 1-1/4" LG	8
25	830301	802 BEATER IDLER SHAFT W/A	2
26	830333	532/672 L/H CHISEL POINT DEFLECTOR W/A	AN
27	830334	532/672 R/H CHISEL POINT DEFLECTOR W/A	AN
28	830387	532B FRAME W/A, VERTICAL BEATER	1
29	830393	532/672 LEFT VERTICAL BEATER W/A	1
30	830394	532/672 RIGHT VERTICAL BEATER W/A	1

532-16B SPREADER SLIDING GATE ASSEMBLY

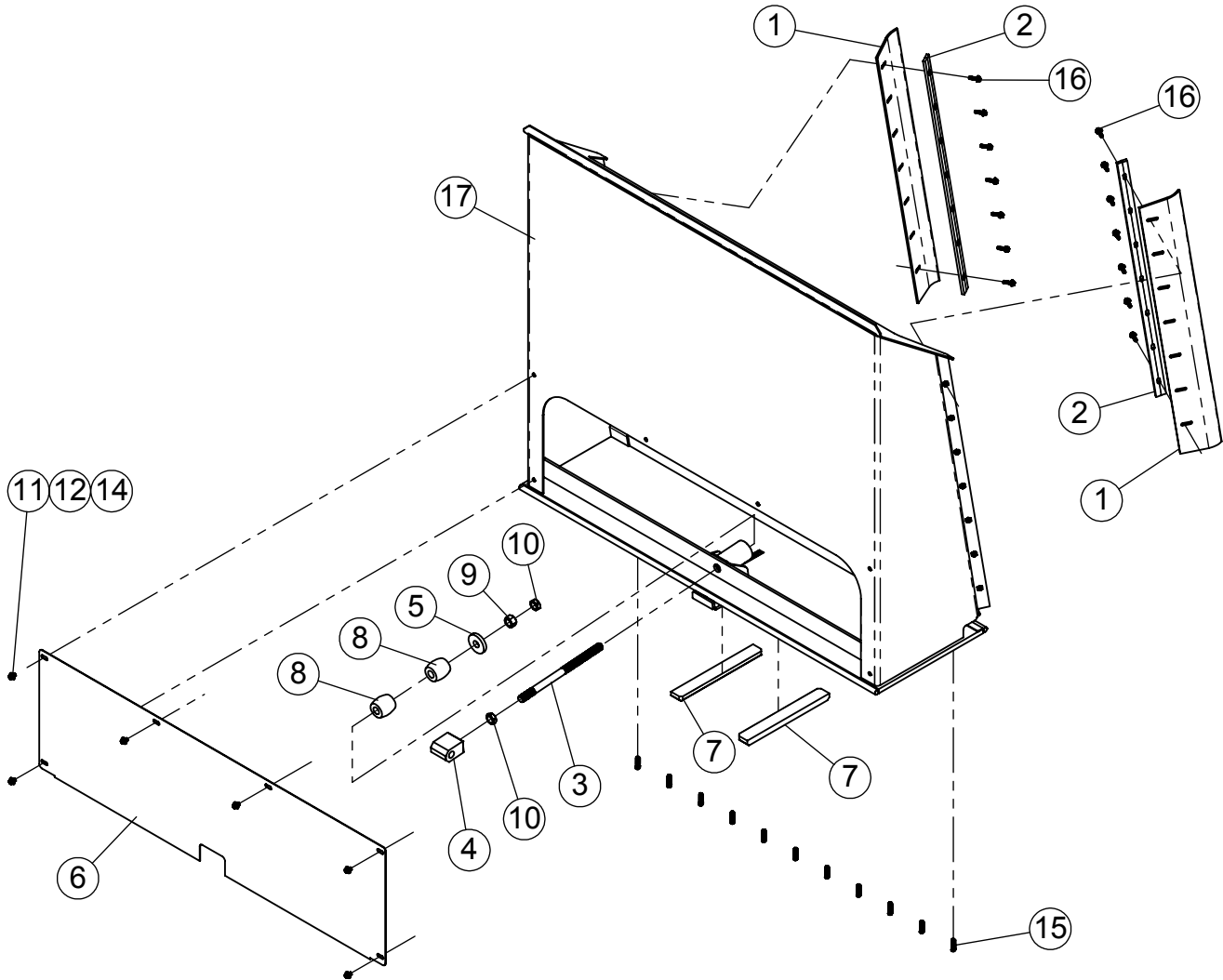

ITEM #	PART #	DESCRIPTION	QTY.
1	130428	SCRAPER (6 1/2" x 48")	2
2	130429	CLAMP, SCRAPER (44 1/2" LG)	2
3	130760	802 FRONT GATE CHAIN ADAPTER	1
4	130762	802 CHAIN LUG (3 1/2" LG)	1
5	130956	802 WASHER, 1/2 x 1-1/16 x 3"	1
6	131124	FRONT GATE COVER	1
7	131125	UHMW GUIDE BLOCK	2
8	351987	URETHANE STRIPPER - 2-1/4"D x 3"LG	2
9	400216	HEX NUT 1"-8 #5 PLTD	1
10	400616	HEX JAMNUT 1"-8 #5 PLTD	2
11	402006	WASHER SPRING LOCK 3/8" MED PLTD	6
12	402406	FLAT WASHER 3/8" PLTD	6
13	402416	FLAT WASHER 1" MED PLTD	1
14	405652	HHCS 3/8"-16 x 3/4" #5 PLTD	6
15	407730	STUD BOLT, RIBBED NECK 7/16"-20 x 1 3/4" UNF	11
16	407904	HHCS SERRATED 3/8" -16 x 1-1/4" #5 PLTD	14
17	830382	532-B/672-B FRONT GATE WA	1

532-16B SPREADER REAR GATE ASSEMBLY

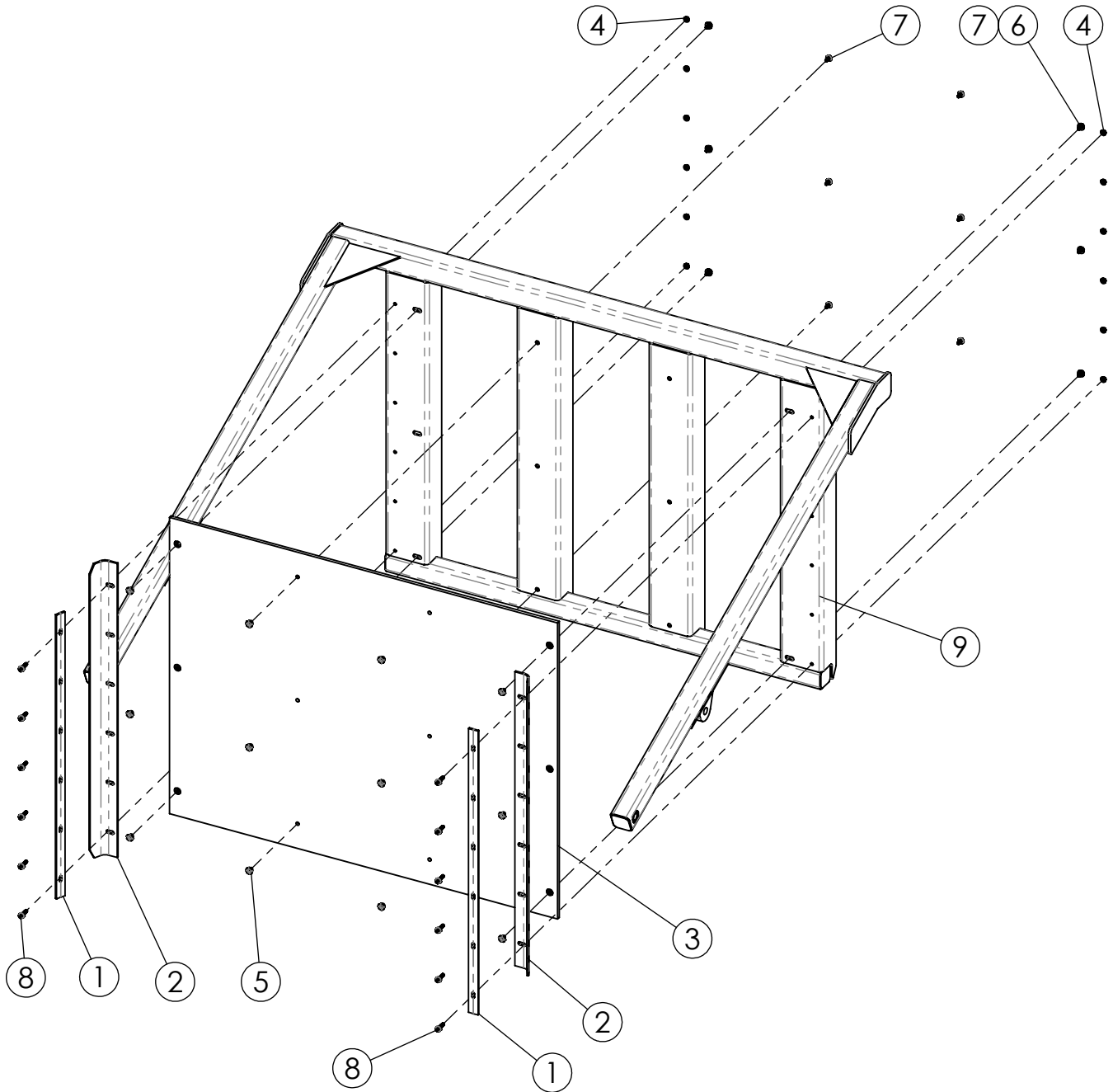

ITEM #	PART #	DESCRIPTION	QTY.
1	130439	FLASHING SEAL CLAMP	2
2	130440	FLASHING, SWINGING GATE	2
3	131098	END GATE LINER	1
4	400119	SERRATED FLANGE HEX NUT 3/8"-16 #5 PLTD	12
5	400150	TEE NUT 3/8"-16 x 5/8"	12
6	402406	FLAT WASHER 3/8" PLTD	6
7	407900	HHCS SERRATED 3/8" -16 X 3/4" #5 PLTD	12
8	407902	HHCS SERRATED 3/8"-16 x 1-1/2" #5 PLTD	12
9	830371	REAR GATE W.A.	1

532-16B SPREADER DECALS

#630042 - 532-16B Decal Kit

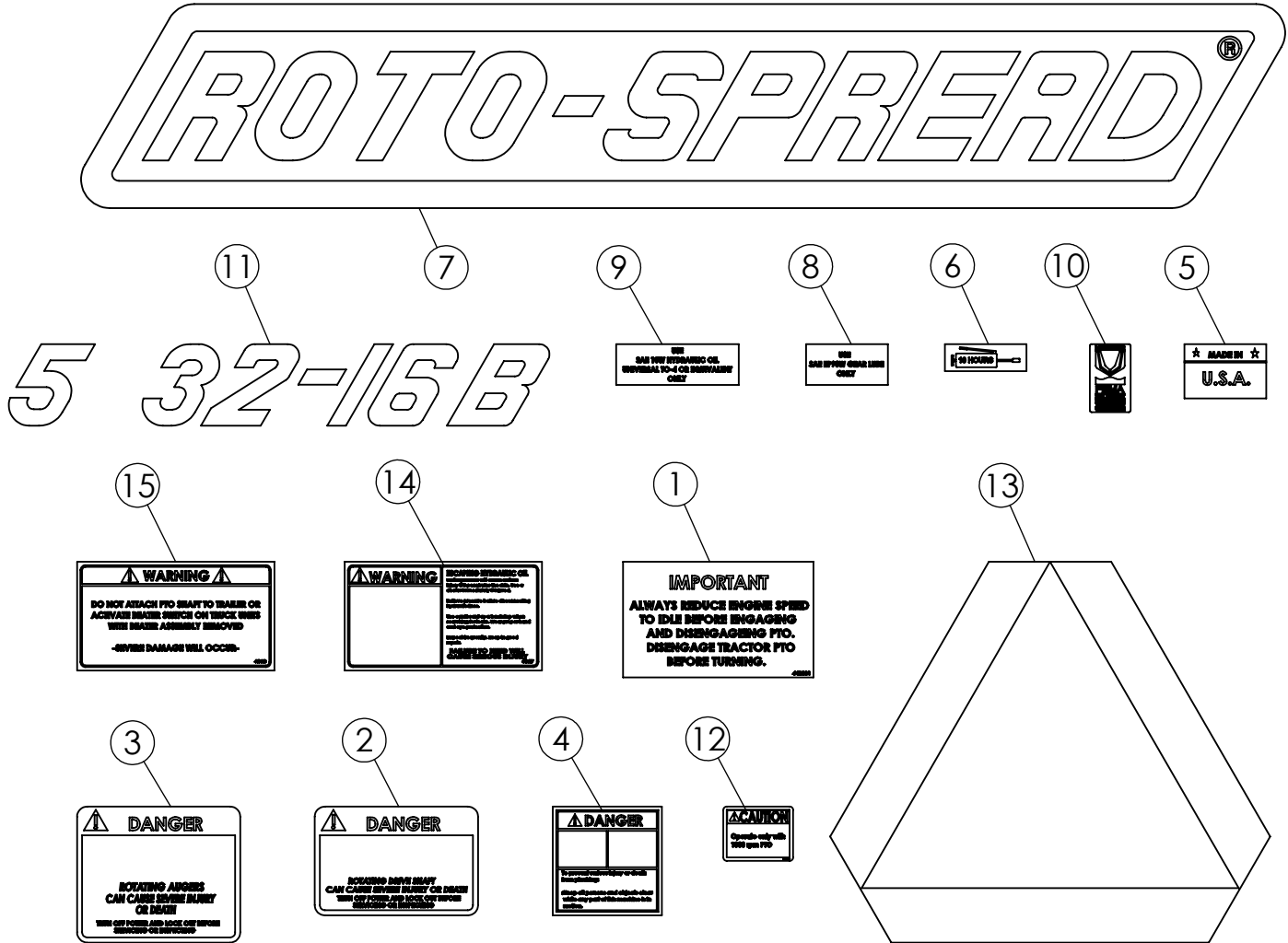

ITEM #	PART #	DESCRIPTION	QTY.
1	440801	DECAL, REDUCE ENGINE SPEED 4-1/4" x 7"	1
2	440826	DECAL, DANGER: ROTATING DRIVE SHAFT	1
3	440827	DECAL, DANGER: ROTATING AUGERS	1
4	440833	DECAL, DANGER PINCH POINT 4"x 4"	1
5	440844	DECAL, MADE IN USA	1
6	440931	DECAL, GREASE GUN DECAL, 10 HOURS	1
7	440939	DECAL, ROTO-SPREAD 7-1/2"x43-9/16"	1
8	440955	DECAL, USE E90W GEAR LUBE ONLY	1
9	440956	DECAL, USE 10W HYD OIL, UNIV TO-4	1
10	440967	DECAL, MEMBER FEMA	1
11	440969	DECAL 532-16B (ROTO-SPREAD)	1
12	441301	DECAL, CAUTION OPERATE AT 1000 PTO	1
13	441405	DECAL SMV	1
14	441657	DECAL, WARNING ESCAPING HYD OIL	1
15	441663	DECAL, WARNING DO NOT ATTACH PTO SHAFT	1

)' &!% 6'F5 @F '8F J 9'G<5: H5GG9A 6@M, ' ' , \$&+

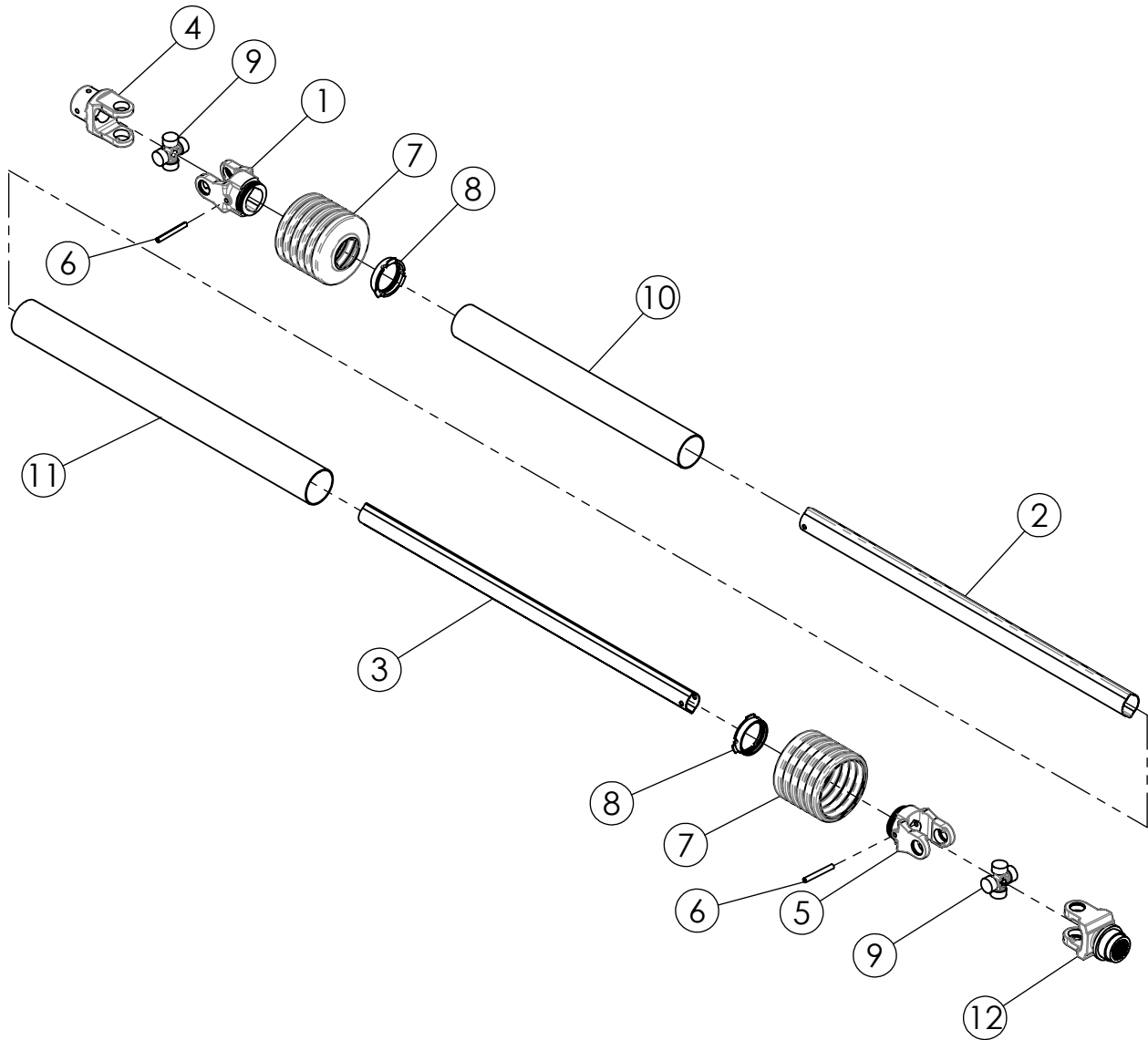

ITEM #	PART #	DESCRIPTION	QTY.
1	338452	INBOARD YOKE W2400 019519	1
2	338579	W- 2400 OUTER PROFILE - 046638	1
3	338578	W-2400 INNER PROFILE - 317341	1
4	338463	Yoke W2400 1-1/2" 3/8"KWY 383388	1
5	338450	INBOARD YOKE W2400 019518	1
6	338473	ROLL PIN #10 METRIC 10 x 80	2
7	338486	SHIELD CONE 6-RIB W-2400 - 365366	2
8	338489	W-2400 BEARING RING SC 25 -087276	2
9	338443	CROSS KIT 1-1/4" x 2-7/8" W2400 312410	2
10	338581	W-2400 INNER SHIELD TUBE ROUND - 094564	1
11	338580	W-2400 OUTER SHIELD TUBE OVL - 056591	1
12	338559	Yoke 1-3/4" - 20 SPL. QD PIN 320671	1

532-16B HYDRAULICS (PUMP)

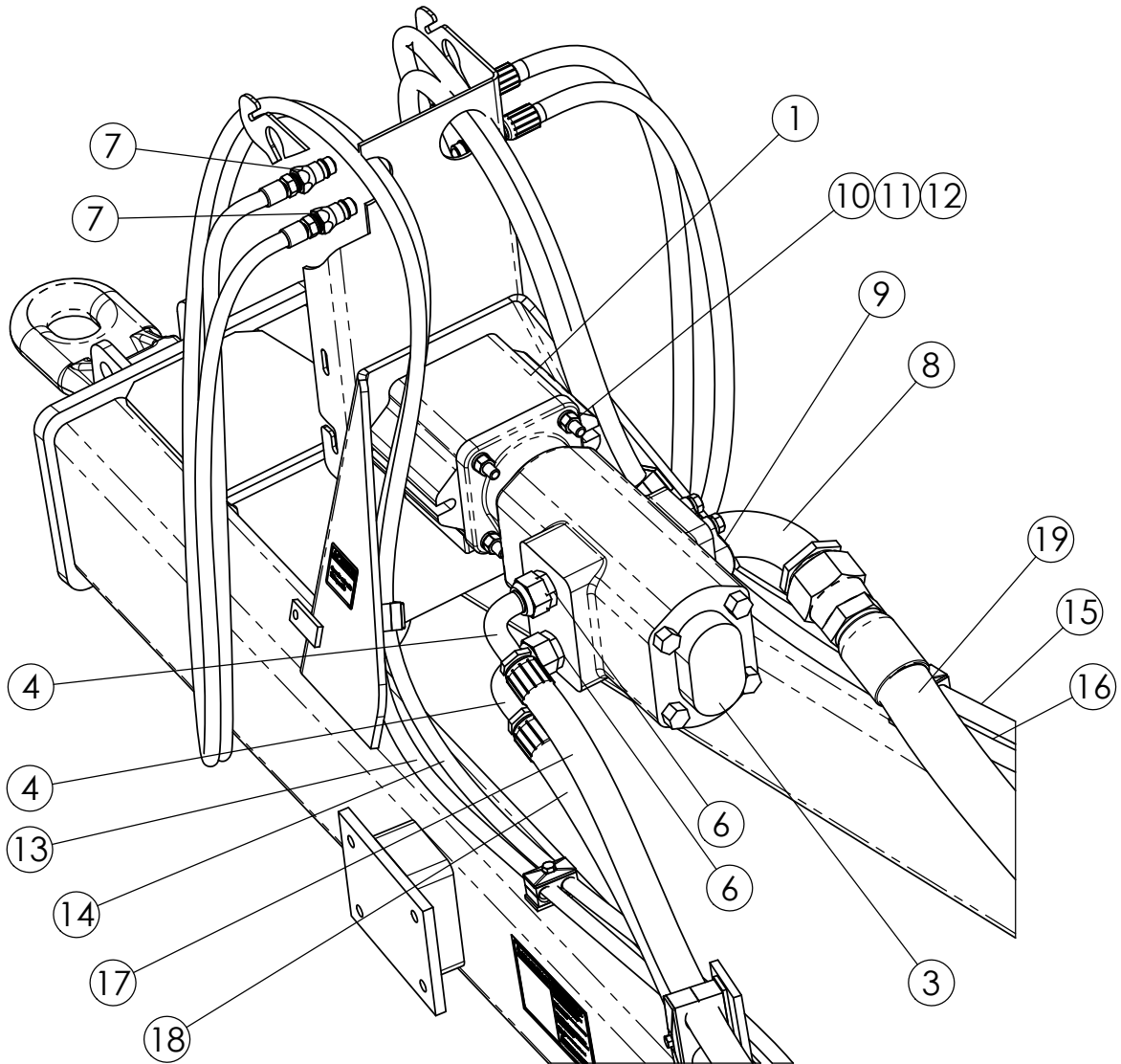

ITEM #	PART #	DESCRIPTION	QTY.
1	344074	OVERHUNG ADAPTER, 1-1/2 KEYED	1
2	344136	GEAR BOX, 25.98:1 REDUCTION	1
3	362030	PUMP ASSY, 7.2 CIR (PERMCO)	1
4	367134	HOSE STEM 16GS-16FFORX90S x 1"	2
5	368136	STRAIGHT ADAPTER, 3/4" MP x 13/16" FFOR	1
6	368193	STRAIGHT ADAPTER, 1-7/16" ORFS x 1-5/16" MORB	2
7	368238	QUICK DISCONNECT, PIONEER-1/2" FP	4
8	368454	90° FLANGE, 2-1/2" JIC x 2" FLANGE	1
9	368456	SPLIT FLANGE KIT, 2" CODE 61	1
10	400208	HEX NUT 1/2"-13 #5 PLTD	4
11	402008	SPRING LOCK WASHER 1/2" PLTD	4
12	405720	HHCS 1/2"-13 x 8" #5 PLTD	4
13	781648	HOSE ASSY, 3/8" x 216" LG (1/2"MP*13/16FFORX90S)	1
14	781648.	HOSE ASSY, 3/8" x 218" LG (1/2MP*13/16FFORX90S	1
15	781654	HOSE ASSY, 1/2" x 240" LG (13/16FFORX90S * 1/2"MP	1
16	781656	HOSE ASSY, 1/2" x 130" LG (1/2MP * 13/16FFORX90L	1
17	781660	HOSE ASSY, 1" x 95" LG (1-7/16FFORX90 * 1-7/16FFORX90S	1
18	781661	HOSE ASSY, 1" x 95-1/2" LG (1-7/16FFORX90S * 1-7/16FFORX90S)	1
19	781664	HOSE ASSY, 2" x 30" LG (2-1/2FJX * 2-1/2FJX)	1

532-16B HYDRAULIC TANK & CHAIN MOTOR

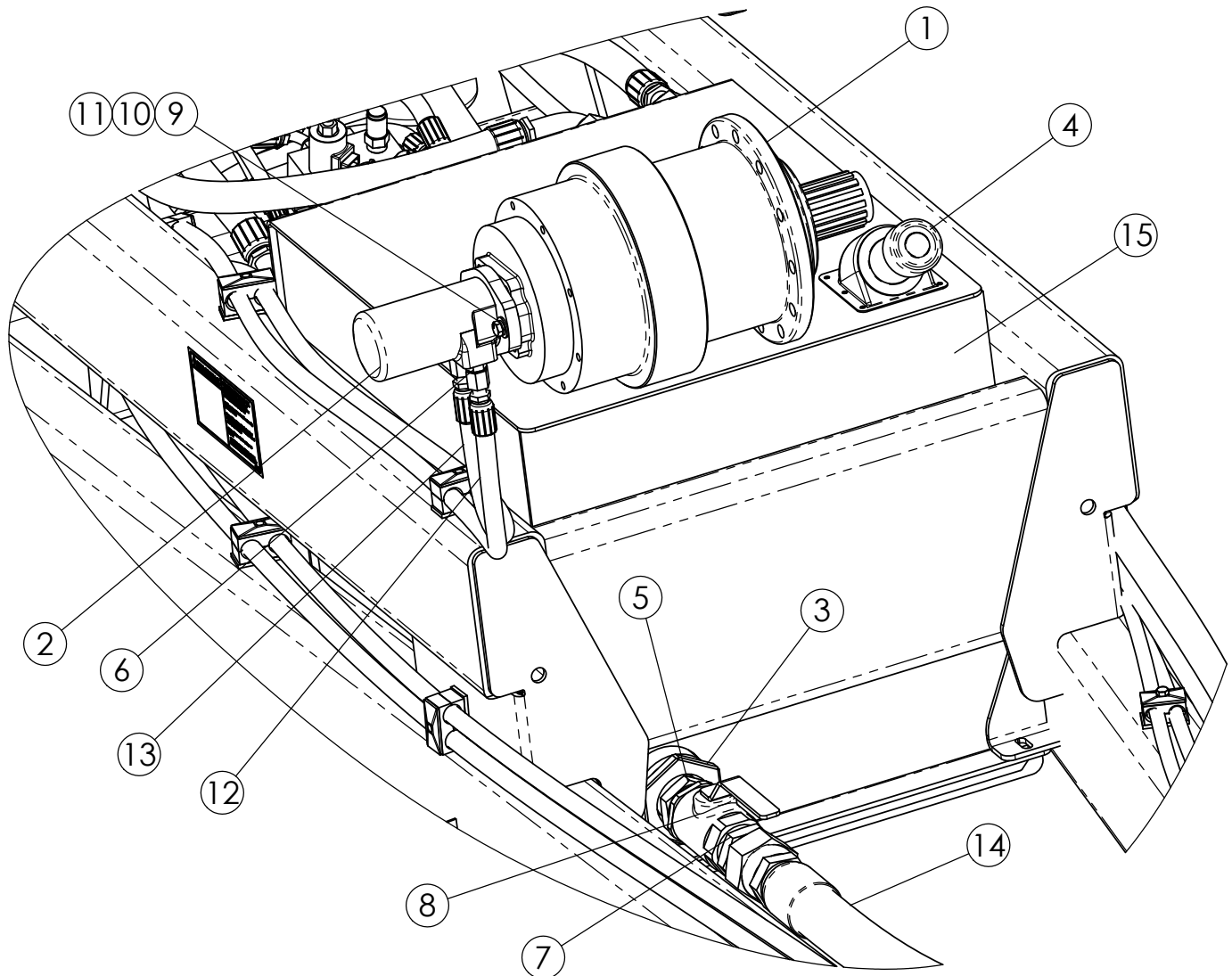

ITEM #	PART #	DESCRIPTION	QTY.
1	344136	GEAR BOX, 25.98:1 REDUCTION	1
2	360023	MOTOR, CHAR-LYNN T SERIES, 18.7 CID	1
3	362508	STRAINER, SUCTION	1
4	362552	SIDE FILLER HI-NECK ASSY	1
5	368130	STRAIGHT ADAPTER, 2" MP x 2" MP HEX NPL	1
6	368191	STRAIGHT ADAPTER, 13/16" ORFS x 7/8" MORB	2
7	368423	STRAIGHT ADAPTER, 2-1/2" JIC x 2" MP	1
8	368523	BALL VALVE, 2" FP	1
9	402006	SPRING LOCK WASHER 3/8" MED PLTD	2
10	402406	FLAT WASHER, 3/8" ID x 1" OD	2
11	407818	HHCS METRIC 10mm-1.5 x 80mm	2
12	781643	HOSE ASSY, 1/2" x 91"LG (13/16FFFORX90S*13/16FFROX)	1
13	781644	HOSE ASSY, 1/2" x 79"LG (13/16FFFORX90S*13/16FFFORX)	1
14	781664	HOSE ASSY, 2" x 30" LG (2-1/2FJX * 2-1/2FJX)	1
15	830361	532 TRUCK RESERVOIR W/A, (68 GAL)	1

532-16B HYDRAULIC VALVE BLOCK & FITTINGS

VIEWED FROM: BOTTOM
LEFT HAND SIDE

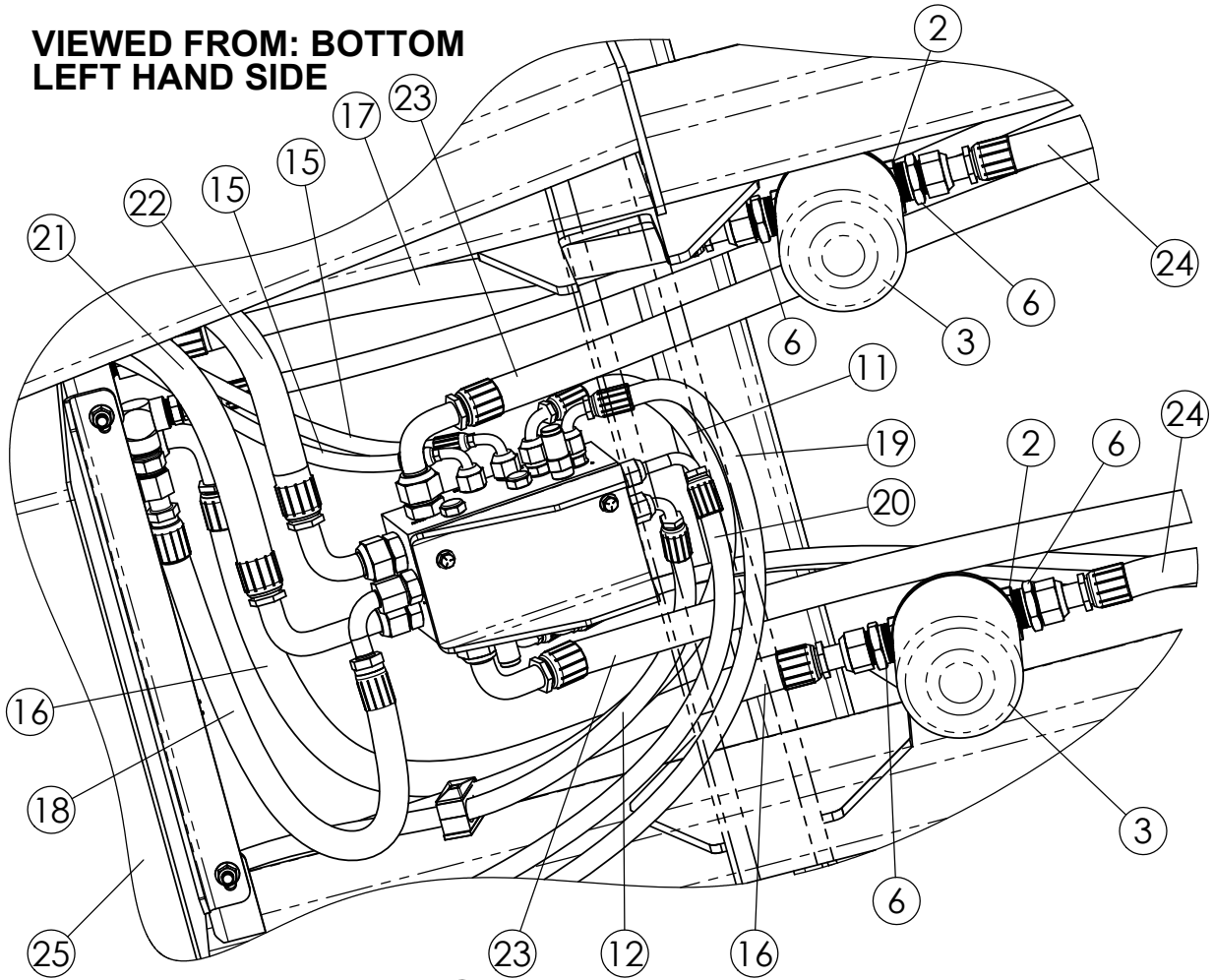

VIEWED FROM: TOP
RIGHT HAND SIDE

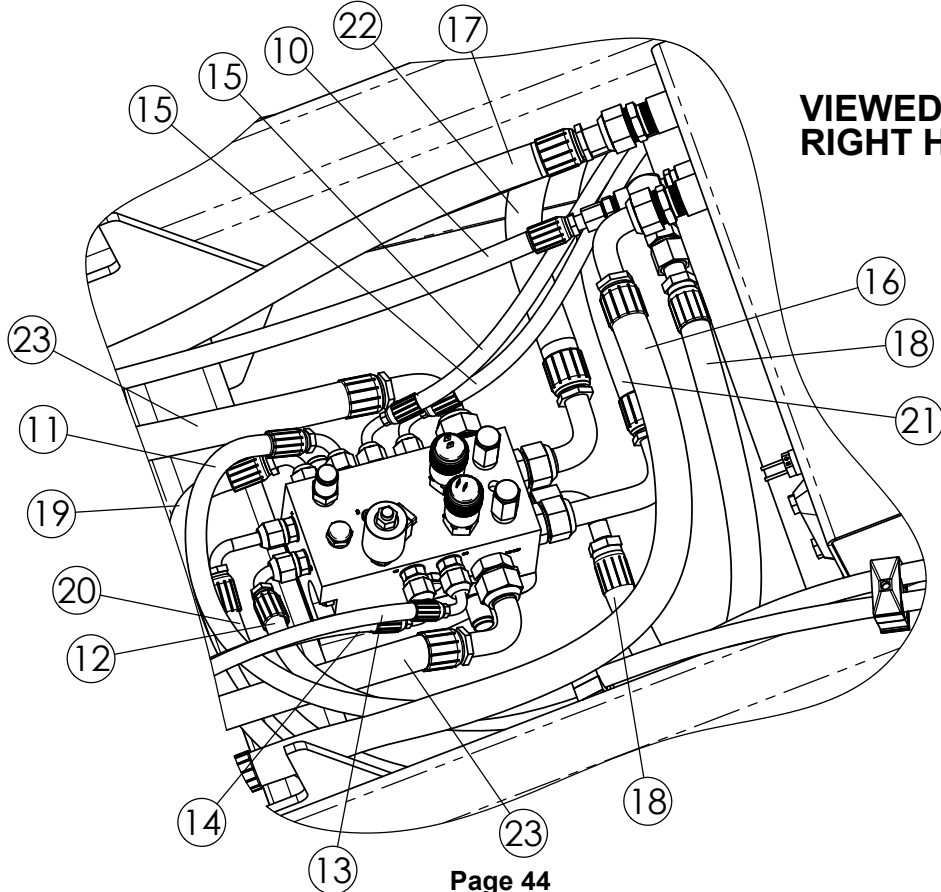

532-16B HYDRAULIC VALVE BLOCK & FITTINGS

VIEWED FROM: TOP
LEFT HAND SIDE

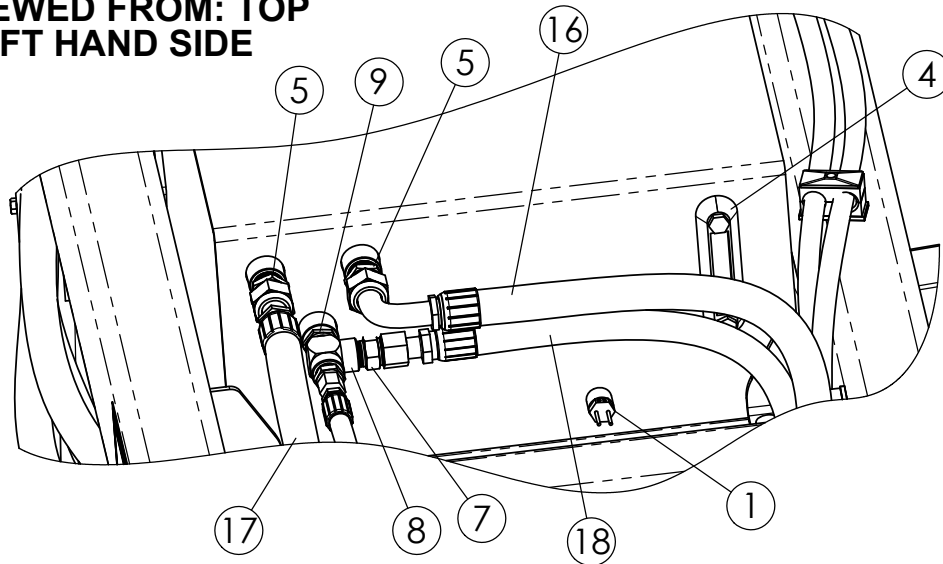

ITEM #	PART #	DESCRIPTION	QTY.
1	357743	LEVEL SWITCH, ACT #N6200N	1
2	362404	FILTER HEAD, 1-1/4" FP	2
3	362442	FILTER ELEMENT	2
4	362555	SIGHT GAUGE 5"	1
5	368134	STRAIGHT ADAPTER, 1" MP x 1-7/16 ORF	2
6	368143	STRAIGHT ADAPTER, 1-1/4" MP x 1-7/16" ORFS	4
7	368144	STRAIGHT ADAPTER, 1-3/16" ORFS x 1-1/16" MORB	1
8	368616	TEE, 3/4" MP x 3/4" FP x 3/4" STREET	1
9	368670	REDUCER 1" MP x 3/4" FP BRASS	1
10	781642	HOSE ASSY, 1/2" x 197" (2- 13/16FFORX)	1
11	781643	HOSE ASSY, 1/2" x 91" (13/16FFORX90S*13/16FFROX)	1
12	781644	HOSE ASSY, 1/2" x 79" (13/16FFORX90S*13/16FFORX)	1
13	781646	HOSE ASSY, 3/8" x 94" (13/16 FFORX90S*9/16FJX)	1
14	781647	HOSE ASSY, 3/8" x 93" (13/16FFORX90S*13/16FFORX)	1
15	781648	HOSE ASSY, 3/8" x 216" (1/2MP*13/16FFORX90S)	2
16	781650	HOSE ASSY, 1" x 33" (1-7/16 FFORX*1-7/16 FFORX90S)	1
17	781651	HOSE ASSY, 1" x 24" (1-7/16 FFORX*1-7/16FFORX90S)	1
18	781652	HOSE ASSY, 3/4" x 30" (1-3/16FFORX*1-3/16FFORX90S)	1
19	781654	HOSE ASSY, 1/2 x 240" (13/16FFORX90S*1/2MP)	1
20	781656	HOSE ASSY, 1/2 x 130" (1/2MP*13/16FFORX90L)	1
21	781660	HOSE ASSY, 1" x 95" (1-7/16FFORX90*1-7/16FFORX90S)	1
22	781661	HOSE ASSY, 1" x 95-1/2" (1-7/16FFORX90S*1-7/16FFORX90S)	1
23	781662	HOSE ASSY, 1" x 188" (1-7/16FFORX*1-7/16FFORX)	2
24	781663	HOSE ASSY, 1" x 164" (1-7/16FFORX*1-7/16FFORX)	2
25	830361	532 TRUCK RESERVOIR W/A, (68 GAL)	1

532-16B HYDRAULIC CYLINDERS - REAR GATE

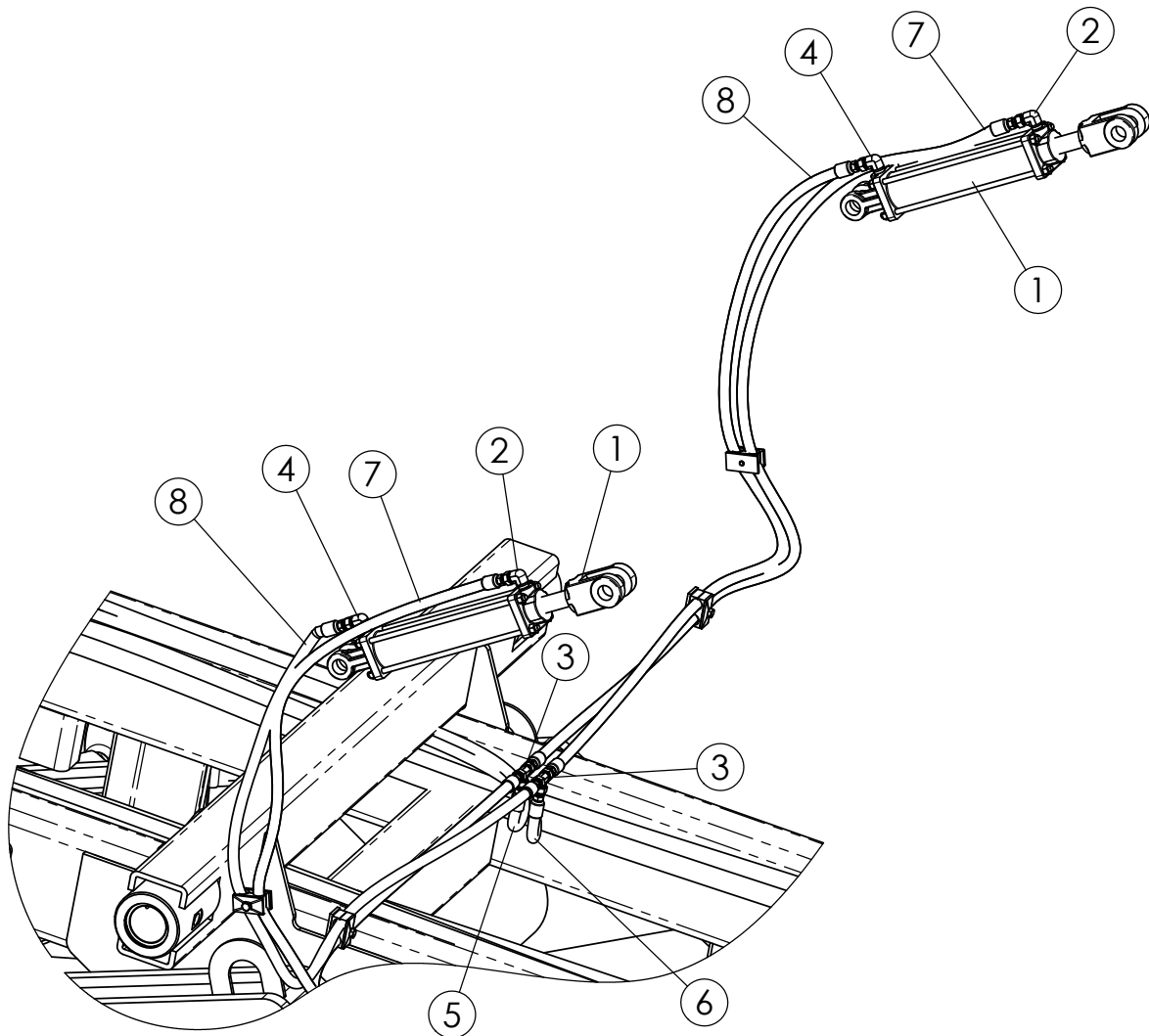

ITEM #	PART #	DESCRIPTION	QTY.
1	364073	HYDRAULIC CYLINDER 2-1/2" x 8" x 20-1/4"	2
2	368009	90° ELBOW, 3/8" MP x 9/16" JIC .031 ORFICE	2
3	368022	TEE, 9/16"-18 JIC (UNION)	2
4	368033	90° ELBOW, 3/8" MP x 9/16" JIC	2
5	781646	HOSE ASSY, 3/8" x 94" (13/16FFORX90S*9/16FJX)	1
6	781647	HOSE ASSY, 3/8" x 93" (13/16FFORX90S*13/16FFORX)	1
7	781658	HOSE ASSY 3/8" x 78" (9/16FJX*9/16FJX)	2
8	781659	HOSE ASSY 3/8" x 66" (9/16FJX*9/16FJX)	2

532-16B BEATER MOTOR HYDRAULICS

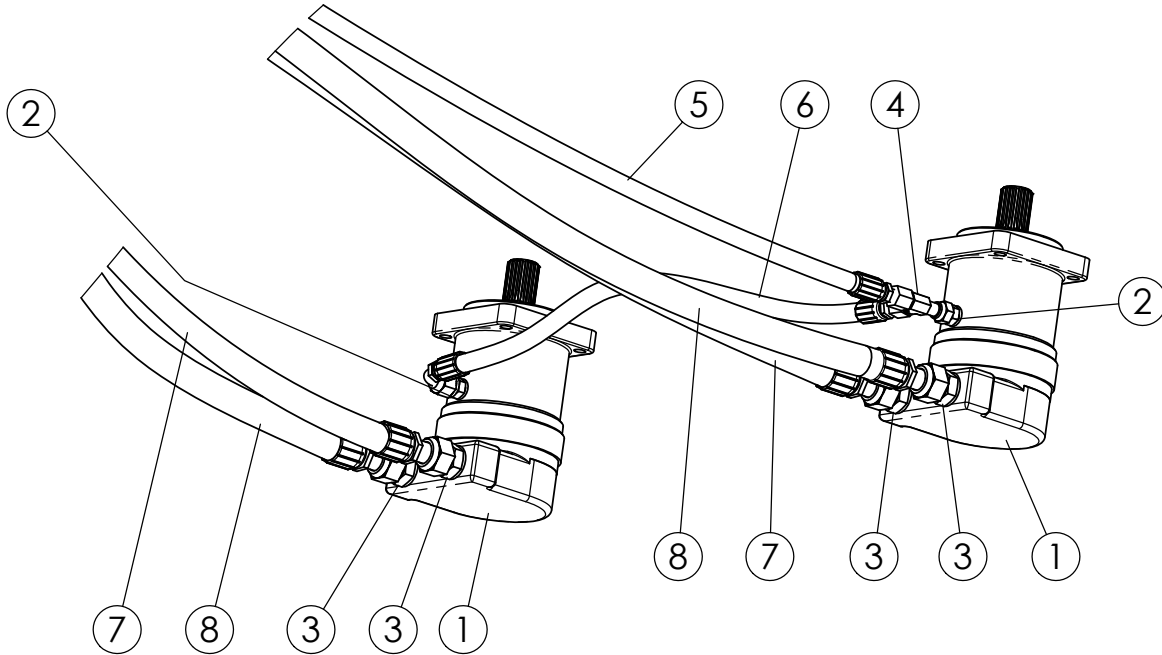

ITEM #	PART #	DESCRIPTION	QTY.
1	360045	HYDRAILIC MOTOR 24.4 CIR VIS	2
2	368190	STRAIGHT ADAPTER, 13/16" ORFS x 9/16" MORB	2
3	368417	STRAIGHT ADAPTER, 1-7/16" ORFS x 1-1/16" MORB	4
4	368636	TEE, 13/16" ORFS SWIVEL RUN	1
5	781642	HOSE ASSY, 1/2" x 197" (2 - 13/16FFORX)	1
6	781653	HOSE ASSY, 1/2" x 33" (13/16FFORX*13/16FFORX)	1
7	781662	HOSE ASSY, 1" x 188" (1-7/16FFORX*1-7/16FFORX)	2
8	781663	HOSE ASSY, 1" x 164" (1-7/16FFORX*1-7/16FFORX)	2

532-16B TRAILER MANIFOLD VALVE ASSEMBLY

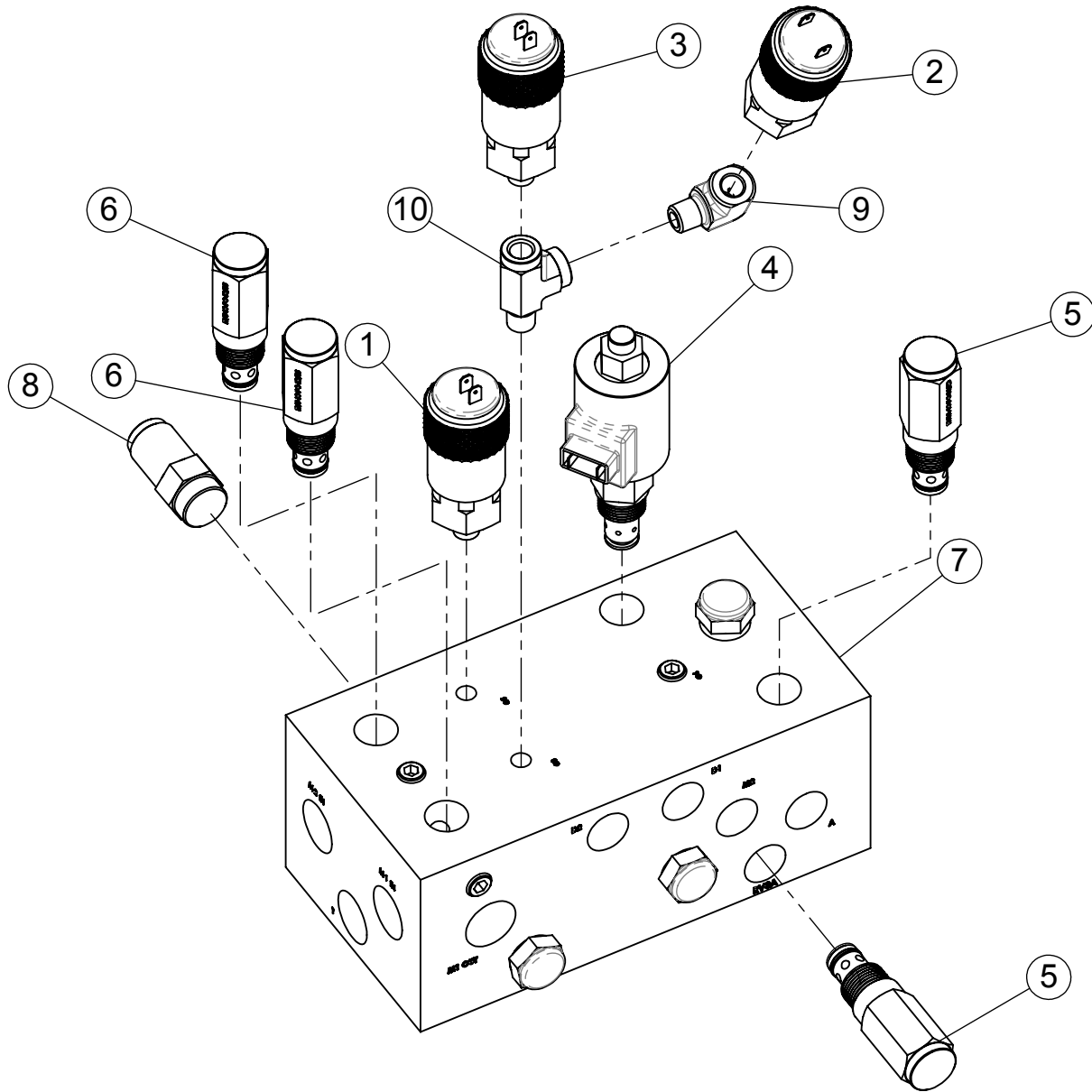

ITEM #	PART #	DESCRIPTION	QTY.
1	357747	PRESSURE SWITCH N/O, NASON PRESET 1500 PSI	1
2	357748	PRESSURE SWITCH N/C, NASON PRESET 3500 PSI	1
3	357749	PRESSURE SWITCH N/O, NASON PRESET 3400 PSI	1
4	362297	PROPORTIONAL FLOW CONTROL CART, (REMOTE)	1
5	362299	RELIEF VALVE, VICKERS RV3-10-F-0-36/20	2
6	362348	RELIEF VALVE, RV5-10-F-G-50/35 (EATON#02-164737)	2
7	362362	TRAILER MANIFOLD, 30 GAL (HI DISP PUMP)	1
8	362370	PRESSURE SEQUENCE VALVE (PSV4-10-F-0-56/33)	1
9	368017	90° ADAPTER, 1/4" MP x 1/4" FP (STEEL)	1
10	368651	TEE, 1/4" STREET (STEEL)	1

532-16B TRAILER WIRING SCHEMATIC WITH FLOW CONTROL

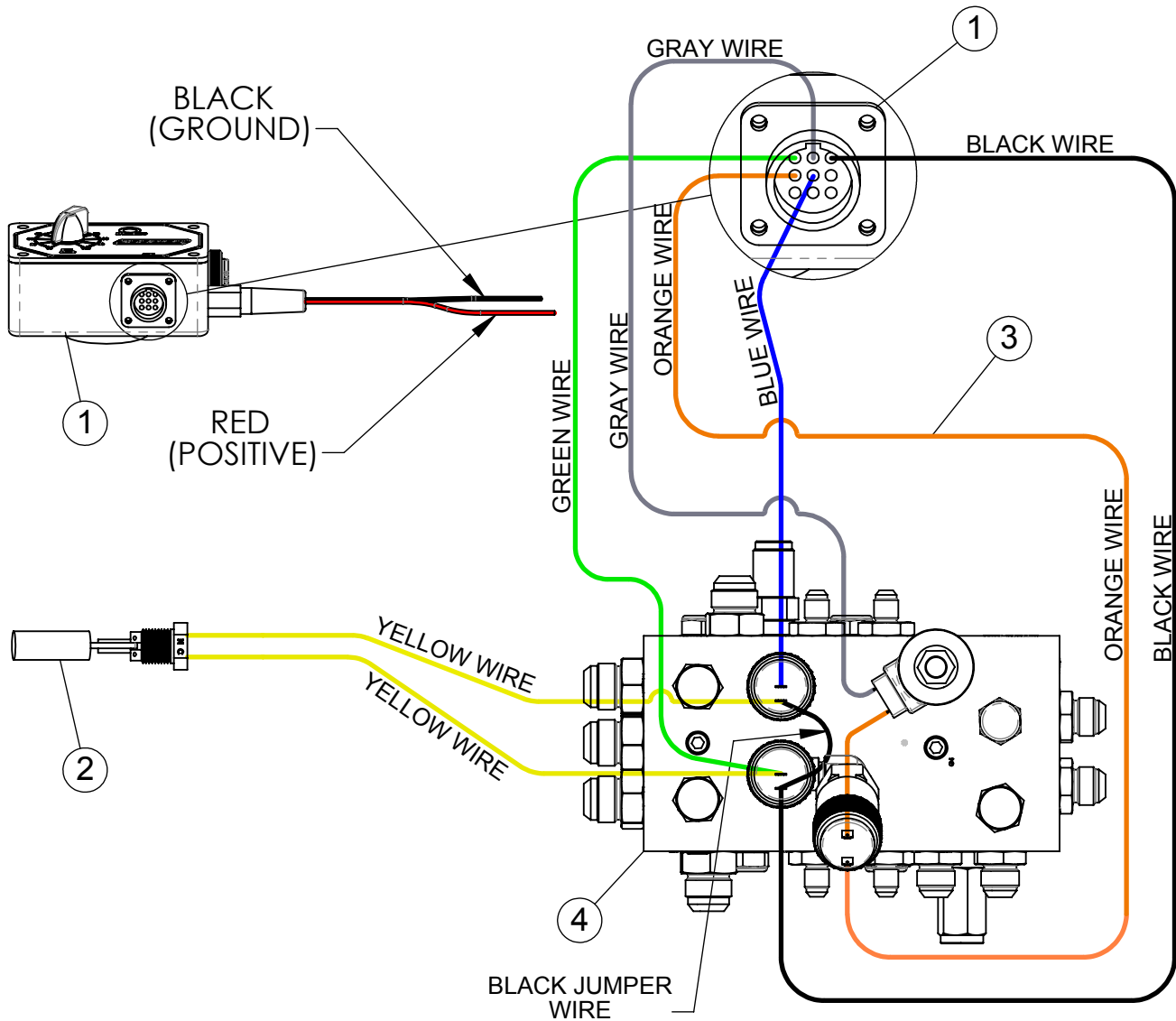

ITEM #	PART #	DESCRIPTION	QTY.
1	357726	REMOTE CONTROL BOX ASSY	1
2	357743	LEVEL SWITCH, ACT #N6200N	1
3	358418	WIRE HARNESS, SPREADER REMOTE	1
4	362362	HI-TORQ TRAILER MANIFOLD ASSY (MCD 9058)	1