

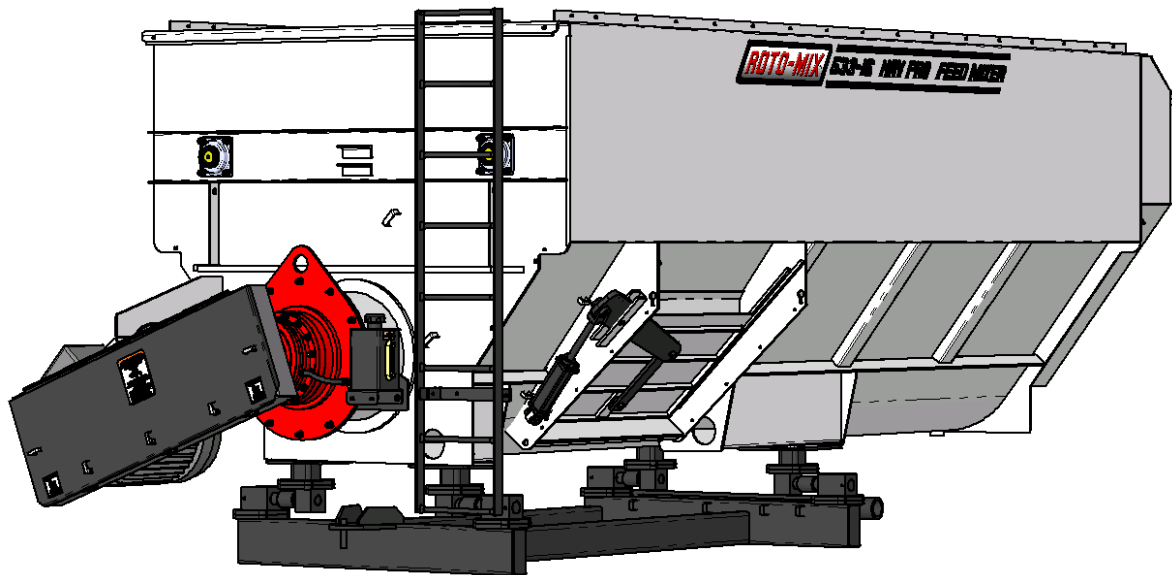

HAY PRO FEED MIXERS

533-16 STATIONARY OPERATION AND PARTS MANUAL



ROTO-MIX LLC
P.O. BOX 1724
2205 E. Wyatt Earp Blvd.
Dodge City, Kansas 67801
(620) 225-1142
©ROTO-MIX 2006

TABLE OF CONTENTS

	PAGE NO.
WARRANTY	4
SCALES WARRANTY & SERVICE POLICY.....	5
OPERATOR QUALIFICATIONS	6
SAFETY	7-16
OPERATION	17
MAINTANENCE	17
DIMENSIONAL SPECIFICATIONS.....	18
LUBRICATION.....	20
TROUBLE SHOOTING.....	21
V-BELT TENSIONING INSTRUCTIONS.....	22-23
PARTS PAGES TABLE OF CONTENTS.....	25



Limited Warranty Statement

ROTO-MIX LLC warrants to the original purchaser all products manufactured by it to be free from defects in material and workmanship under normal use and service.

ROTO-MIX's obligation under this warranty is limited to repairing or replacing, as the company may elect, free of charge and without charge for installation, at the place of business of a dealer or distributor authorized to handle the equipment covered by this warranty or at a ROTO-MIX facility, any parts that prove, in the company's judgment, to be defective in material or workmanship within one (1) year after delivery to the original purchaser, and still owned by the original purchaser. This warranty shall in no way make ROTO-MIX liable to anyone for personal injuries or damages, loss of time, or expense of any kind either direct or indirect resulting from part failure or defect. This warranty is subject to acts of God, fire and existing conditions of supply and demand, or production, or ability or inability to deliver, or for any other valid reason beyond the reasonable control of ROTO-MIX, to obtain materials, manufactured replacement parts, or make delivery thereof. No distributor, dealer, agent, or ROTO-MIX employee (other than the CEO or President in writing) is authorized to extend any other or further express or implied warranty or incur any additional obligation on ROTO-MIX's behalf in connection with the sale of this product.

If ROTO-MIX, or its duly authorized representative, shall find that such returned part or parts are defective and such defects, or defect, are included in and covered by said warranty, then such defective part or parts shall promptly be replaced without charge to the purchaser, F.O.B. the ROTO-MIX plant.

Product Registration - It is a condition of this warranty that the original purchaser must fill out the warranty card furnished by ROTO-MIX and that it be returned to ROTO-MIX within 10 days of purchase and be recorded in ROTO-MIX's owner file for this warranty to be valid. In the event an owner's card is not on file at the ROTO-MIX office, the warranty period will extend only from date equipment was picked up or shipped from the ROTO-MIX plant.

Maintenance - It is the customer's responsibility to maintain their equipment in accordance with the instructions provided in the Operator's Manual. ROTO-MIX recommends that you keep records and receipts; you may be asked to prove that maintenance instructions have been followed.

Operation - It is the customer's responsibility to operate the equipment only for the purpose for which it was designed and in accordance with all safety and operational recommendations contained in the Operators Manual. If a defect in materials or workmanship occurs, it is the customer's responsibility to cease operating the equipment until authorized repairs are made. **Damage, which occurs from continued operation, may not be covered by this warranty.**

What this Warranty Covers

This warranty covers failures caused by defects in materials or workmanship only.

This Warranty does **not** cover failures caused by:

- Improper operation
- Natural calamities
- Unauthorized modifications
- Unauthorized repairs
- Use of Non ROTO-MIX parts
- Neglected maintenance
- The use of PTO Shaft Adaptors
- Usage contrary to the intended purpose of the product

Warranty continues on the next page.

Limited Warranty Statement continued

This Warranty does not cover replacement of Wear or Maintenance Items including, but not limited to.

- | | | | |
|--------------|----------|-------------|----------|
| - Lubricants | - Tires | - Chains | - Blades |
| - Filters | - Augers | - Idlers | - Belts |
| - Hoses | - Wipers | - Batteries | |

This Warranty does not cover:

- Pickup and delivery of the equipment
- Service Calls or Travel Time to and from sites
- Rental of replacement equipment during repair period
- Products that have been declared a total loss and subsequently salvaged
- Overtime labor charges
- ROTO-MIX is not responsible and will not be liable for damage caused to persons or property, commercial loss, loss of time or production, loss of use by reason of the installation or use of ROTO-MIX products or their mechanical failure.

Right to Make Changes

ROTO-MIX reserves the right to make any changes to a ROTO-MIX product at any time without incurring any obligation with respect to any product previously ordered, sold or shipped, with or without notice.

Parts Warranty

ROTO-MIX warrants replacement parts against defects in materials or workmanship for a period of 90 days or the remainder of the product warranty, whichever is longer. Remedy for defective replacement parts for units that are beyond the original product warranty, will be limited to replacement of the failed part. Failures that are due to damage, improper installation, lack of maintenance or improper operation will not be covered.

ROTO-MIX 2205 East Wyatt Earp Blvd., Dodge City, KS 67801 (620) 225-1142 Fax: (620) 225-6370

SCALES WARRANTY & SERVICE POLICY

DIGI-STAR SCALE SYSTEMS

Digi-Star, LLC warrants for a period of one year from date of installation, to correct by repair or replacement, at Digi-Star's option, any defect in material or workmanship in any part of this product. In the event of replacement, Digi-Star's sole obligation shall be to provide replacement products or parts. F.O.B. Digi-Star, LLC, W5527 Hwy 106, Fort Atkinson, WI 53538 USA.

WEIGH-TRONIX SCALE SYSTEMS

WEIGH-TRONIX warrants for a period of one year from date of installation, to correct by repair or replacement, at Weigh-Tronix's option, any defect in material or workmanship in any part of this product. In the event of replacement, Weigh-Tronix's sole obligation shall be to provide replacement products or parts. F.O.B. Avery Weigh-Tronix, 1000 Armstrong Drive, Fairmont, MN 56031-1439 USA.

OPERATOR QUALIFICATIONS

Operation of this mixer shall be limited to competent and experienced persons. In addition, anyone who will operate or work around this mixer must use good common sense. In order to be qualified, he or she must also know and meet all other qualifications, such as:

1. Some regulations specify that no one under the age of sixteen (16) may operate power machinery. It is your responsibility to know what these regulations are in your area and/or situation.
2. Current OSHA regulations state in part: At the time of initial assignment and at least annually thereafter, the employer shall instruct **EVERY** employee in the safe operation and servicing of all equipment with which the employee is, or will be involved.
3. Unqualified persons are to **STAY OUT OF THE WORK AREA.**
4. A person who has not read and understood all operating and safety instructions is not qualified to operate the machinery.

FAILURE TO READ THIS MIXER MANUAL AND ITS SAFETY INSTRUCTIONS IS A MISUSE OF THE EQUIPMENT.



SAFETY

TAKE NOTE! THIS SAFETY ALERT SYMBOL FOUND THROUGHOUT THIS MANUAL IS USED TO CALL YOUR ATTENTION TO INSTRUCTIONS INVOLVING YOUR PERSONAL SAFETY AND THE SAFETY OF OTHERS. FAILURE TO FOLLOW THESE ISTRUCTIONS CAN RESULT IN INJURY OR DEATH.



THIS SYMBOL MEANS

-ATTENTION!

-BECOME ALERT!

-YOUR SAFETY IS INVOLVED!

SIGNAL WORDS: Note the use of the signal words DANGER, WARNING, and CAUTION with the safety messages. The appropriate signal word for each has been selected using the following guidelines:

DANGER: Indicates an imminently hazardous situation that, if not avoided, will result in serious injury or death. This signal word is to be limited to the most extreme situations typically for machine components which, for functional purposes, cannot be guarded.

WARNING: Indicates a potentially hazardous situation that, if not avoided, will result in serious injury or death, and includes hazards that are exposed when guards are removed. It may also be used to alert against unsafe practices.

CAUTION: Indicates a potentially hazardous situation that, if not avoided, may result in minor or moderate injury. It may also be used to alert against unsafe practices.

If you have questions not answered in this manual or require additional copies or the manual is damaged, please contact your dealer or ROTO-MIX, 2205 E. Wyatt Earp, Dodge City, Kansas, 67801. (Telephone) 620-225-1142 (Fax) 620-225-6370

SAFETY FIRST

REMEMBER: The careful operator is the best operator. Most accidents are caused by human error. Certain precautions must be observed to prevent the possibility of injury or death.



DO NOT ALLOW PERSONNEL OTHER THAN THE QUALIFIED OPERATOR NEAR THE MACHINE.



NEVER START MACHINE UNTIL ALL GUARDS AND SAFETY SHIELDS ARE IN PLACE.



DO NOT CLEAN, ADJUST OR LUBRICATE THE MACHINE WHILE IT IS IN MOTION.



LOOSE OR FLOPPY CLOTHING SHOULD NOT BE WORN BY THE OPERATOR.

OPERATING PRECAUTIONS & INSTRUCTIONS

- A. Check to see that no obstructions are present in the mixer prior to start up.
- B. Before loading, run the mixer empty and check all operations.
- C. Do not overload the mixer, as the mixing efficiency may be reduced and unit damage may occur. (See loading instructions).
- D. Remove all moisture drain plugs if the mixer is going to set in the rain or snow.
- E. Be sure all shields are in place before operation.
- F. Use common sense when operating.

EQUIPMENT SAFETY GUIDELINES

Safety of the operator is one of the main concerns in designing and developing a new piece of equipment. Designers and manufactures build in as many safety features as possible. However, every year many accidents occur which could have been avoided by a few seconds of thought and a more careful approach to handling equipment. You, the operator, can avoid many accidents by observing the following precautions in this section. To avoid personal injury, study the following precautions and insist those working with you, or for you, follow them.

In order to provide a better view, certain photographs or illustrations in this manual may show an assembly with a safety shield removed. However, equipment should never be operated in this condition. Keep all shields in place. If shield removal becomes necessary for repairs, replace the shield prior to use.

Replace any CAUTION, WARNING, DANGER or instruction safety decal that is not readable or is missing. Location of such decals are indicated in this manual.

Do not attempt to operate this equipment under the influence of drugs or alcohol.

Review the safety instructions with all users annually.

This equipment is dangerous to children and persons unfamiliar with its operation. The operator should be a responsible adult familiar with farm and industrial machinery and trained in this equipment's operations. Do not allow persons to operate or assemble this until they have read this manual and have developed a thorough understanding of the safety precautions and of how it works.



KEEP ALL SHIELDS IN PLACE

Do not operate mixer without safety shields in place.

Rotating parts can crush or dismember causing personal injury or death.



OPERATE MIXER/FEEDER SAFELY

Rotating parts can entangle or strike people, resulting in personal injury or death.

Never enter a mixer while in operation.

Operate the mixer from a safe distance.



AVOID HIGH-PRESSURE FLUIDS

Escaping fluid under pressure can penetrate the skin causing serious injury or death.

Avoid the hazard relieving pressure before disconnecting hydraulic or other lines. Tighten all connections before applying pressure.

Search for leaks with a piece of cardboard. Protect hands and body from high pressure fluids.

If an accident occurs, see a doctor immediately. Any fluid injected into the skin must be surgically removed within a few hours or gangrene may result. Doctors unfamiliar with this type of injury should reference a knowledgeable medical source.





PRACTICE FIRE PREVENTION

Keep fire extinguishers accessible at all times. Use the extinguisher recommended for the material being processed. It should be rated safe for use on electrical fires.

Never smoke close to combustible material.

Clean the area before welding or other activities which may make sparks.

Keep all components that generate excessive heat clear of oil and other combustible materials.



SAFETY DECAL CARE

Keep safety decals and signs clean and legible at all times.

Replace safety decals and signs that are missing or have become illegible.

Replaced parts that displayed a safety sign should also display the current sign.

Safety decals or signs are available from your dealer or the ROTO-MIX manufacturing plant.

How to Install Safety Decals:

Be sure that the installation area is clean and dry.

Decide on the exact position before you remove the backing paper.

Remove the smallest portion of the split backing paper.

Align the decal over the specified area and carefully press the small portion with the exposed sticky backing in place.

Slowly peel back the remaining paper and carefully smooth the remaining portion of the decal in place.

Small air pockets can be pierced with a pin and smoothed out using the piece of decal backing paper.

533-16 STATIONARY SAFETY DECALS

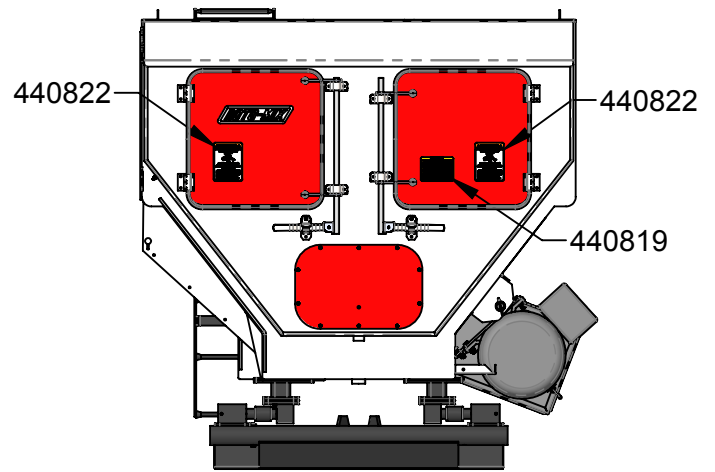
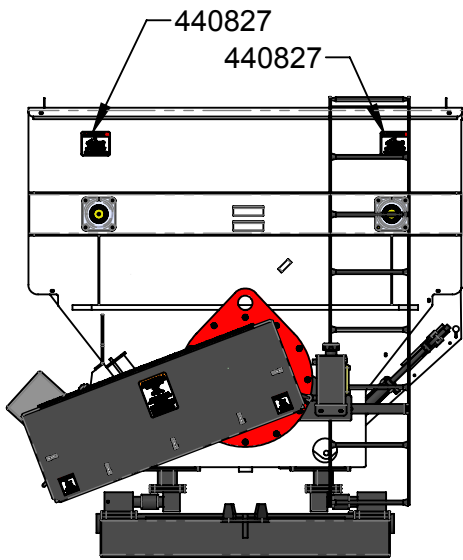
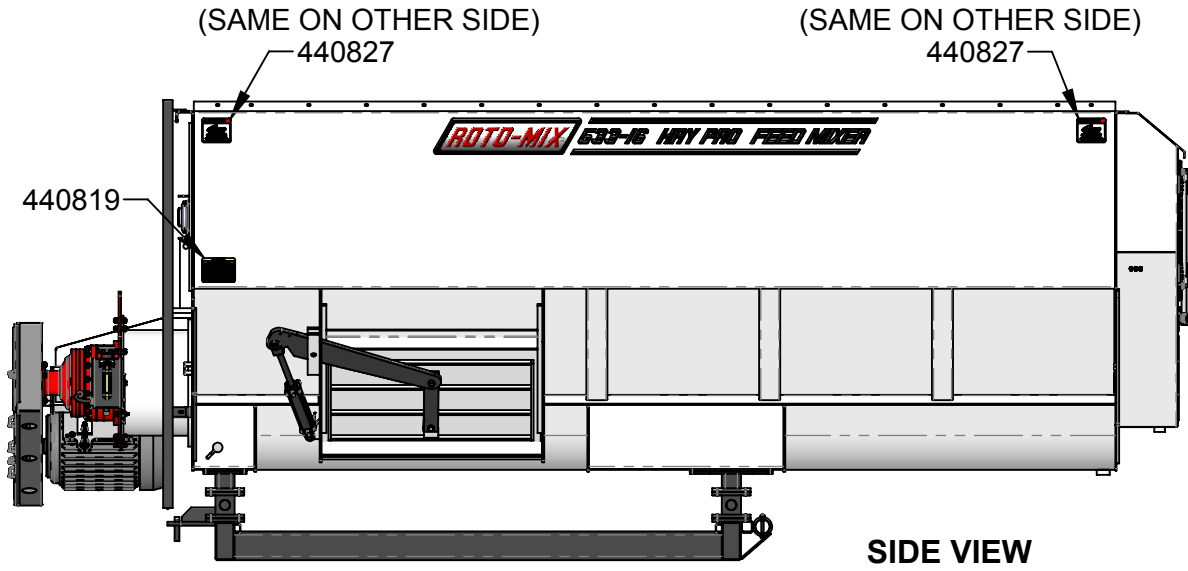

533-16 SAFETY DECALS

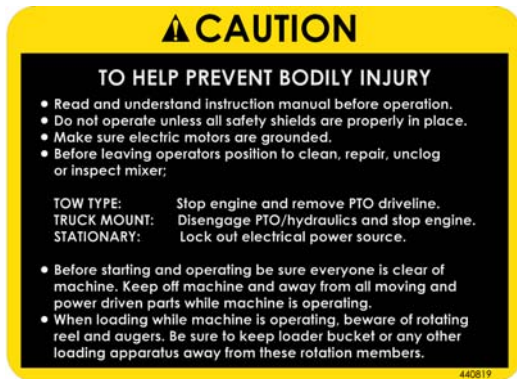

#440819



#440822



#440827



#440035



REMEMBER

Your best assurance against accidents is a careful and responsible operator. If there is any portion of this manual or function you do not understand, contact your dealer or the ROTO-MIX plant.

BEFORE OPERATION:

Carefully study and understand this manual.

Do not wear loose-fitting clothing which may catch in moving parts.

Always wear protective clothing and substantial shoes.

Keep nuts or bolts tightened to specified torque.

Give the unit a visual inspection for any loose bolts, worn parts or cracked welds, and make necessary repairs. Follow the maintenance safety instructions included in this manual.

Be sure that there are no tools lying on or in the mixer/feeder.

Do not use the unit until you are sure that the area is clear, especially children and animals.

Because it is possible that this mixer/feeder may be used in dry areas or the presence of combustibles, special precautions should be taken to prevent fires and fire fighting equipment should be readily available.

Don't hurry the learning process or take the unit for granted. Ease into it and become familiar with your new mixer/feeder.

Practice operation of your mixer/feeder and its attachments. Completely familiarize yourself and other operators with its operation before using.



DURING OPERATION:

Beware of bystanders, **particularly children!** Always look around to make sure that it is safe to start the unit. This is particularly important with higher noise levels, as you may not hear people shouting.

Keep hands and clothing clear of moving parts.

Do not clean, lubricate or adjust your mixer while it is moving.

Be especially observant of the operating area. Always inspect the area prior to operation.

Do not walk or work under raised components or attachments unless securely positioned and blocked.

Keep all bystanders, pets and livestock clear of the work area.

Never leave running mixer unattended.

As a precaution, always recheck the hardware on mixer/feeder following every 100 hours of operation. Correct all problems. Follow the maintenance safety procedures.



FOLLOWING OPERATION:

Following operation, disengage all power drives, shut off the motor and lockout the power switch.



PERFORMING MAINTENANCE:

Good maintenance is your responsibility. Poor maintenance is an invitation to trouble.

Be certain all moving parts on attachments have come to a complete stop before attempting to perform maintenance.

Always use a safety support and block the wheels. Never use a jack to support the machine.

Always use the proper tools or equipment for the job at hand.

Use extreme caution when making adjustments.

Never use your hands to locate hydraulic leaks on attachments. Use a small piece of cardboard or wood. Hydraulic fluid escaping under pressure can penetrate the skin.

When disconnecting hydraulic lines, shut off hydraulic supply and relieve all hydraulic pressure.

Openings in the skin and minor cuts are susceptible to infection from hydraulic fluid. If injured by escaping hydraulic fluid, see a doctor at once. Gangrene can result. Without immediate treatment, serious infection and reactions can occur.

Replace all shields and guards after servicing and before moving.



After servicing, be sure all tools, parts and service equipment are removed.

Do not allow grease or oil to build up on any step or platform.

Never replace hex bolts with less than grade five (5) bolts unless otherwise specified.

Where replacement parts are necessary for periodic maintenance and servicing, genuine factory replacement parts must be used to restore your equipment to original specifications. ROTO-MIX will not claim responsibility for use of unapproved parts and/or accessories and other damages as a result of their use.

If equipment has been altered in any way from original design, ROTO-MIX does not accept any liability for injury or warranty.

READ THE FOLLOWING BEFORE WELDING ON THIS MIXER/FEEDER

When welding on your mixer, do not allow the current to flow through the bearings or the roller chains. Ground directly to the item being welded.

Always disconnect the scale instrumentation from the weigh bars or load cells and the power source. Be sure the current does not pass through weigh bars or load cells or scale indicator.

CHAIN TENSION

All the single roller chain should be tightened to the point of .042" (1 mm) (dime) clearance is reached between the coils of the 1-1/4" idler tension springs and .068" (1.7 mm) (nickel) clearance is reached between the coils of the 1-3/4" idler tension springs.

PRE OPERATION

PRE OPERATION CHECK LIST

1. Carefully study and understand this manual.
2. Do not wear loose fitting clothing which may catch in moving parts.
3. Always wear protective clothing and substantial shoes.
4. Give the unit a visual inspection for any loose bolts, worn parts or cracked welds, and make necessary repairs. Follow the maintenance safety instructions included in this manual.
5. Be sure that there are no tools lying on or in the mixer.
6. Do not use the unit until you are sure that the area is clear, especially of children and animals.
7. Because it is possible that this mixer may be used in dry areas or in the presence of combustibles, special precautions should be taken to prevent fires and fire fighting equipments should be readily available.
8. Don't hurry the learning process or take the unit for granted. Ease into it and become familiar with your new mixer.
9. Practice operation of your mixer and its attachments. Completely familiarize yourself and other operators with its operation before using.

MAINTENANCE

ALWAYS DISCONNECT OR DISENGAGE POWER BEFORE CLEANING, ADJUSTING, LUBRICATION OR SERVICING THIS MACHINE. FAILURE TO HEED MAY RESULT IN SERIOUS PERSONAL INJURY OR DEATH.

533-16 STATIONARY DIMENSIONS

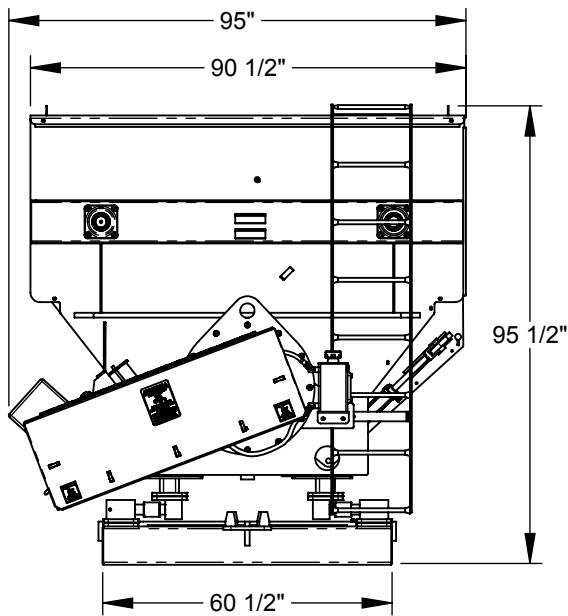
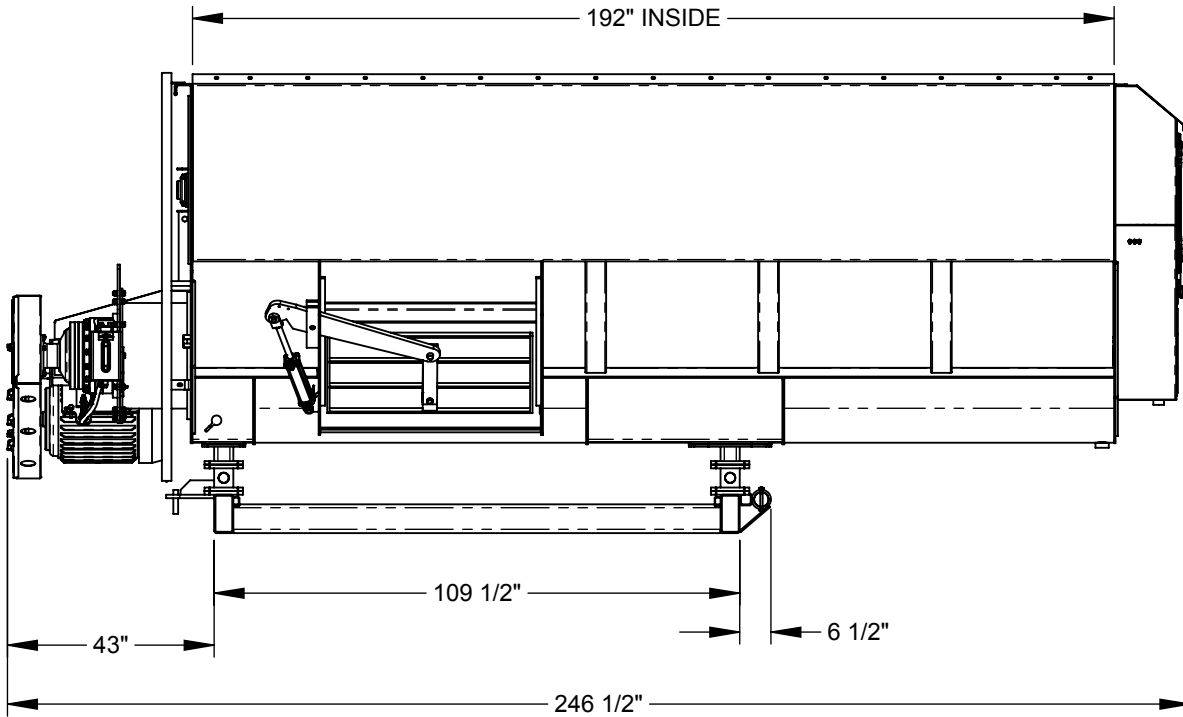

FRONT VIEW

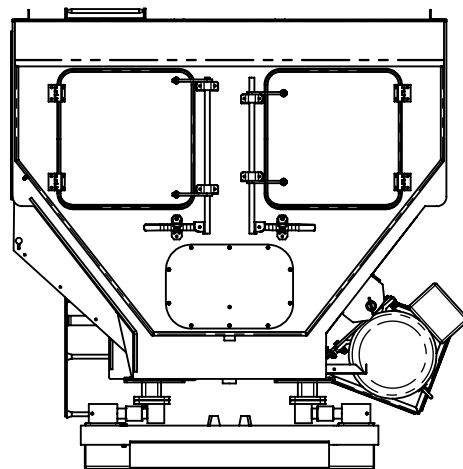

BACK VIEW

All Dimensions & Specifications are Approximate and Subject to Change Without Notice.

This Page intentionally left blank.

LUBRICATION

⚠ WARNING

ALWAYS DISCONNECT OR DISENGAGE POWER BEFORE CLEANING, ADJUSTING, LUBRICATING OR SERVICING THIS MACHINE. FAILURE TO HEED MAY RESULT IN SERIOUS PERSONAL INJURY OR DEATH.

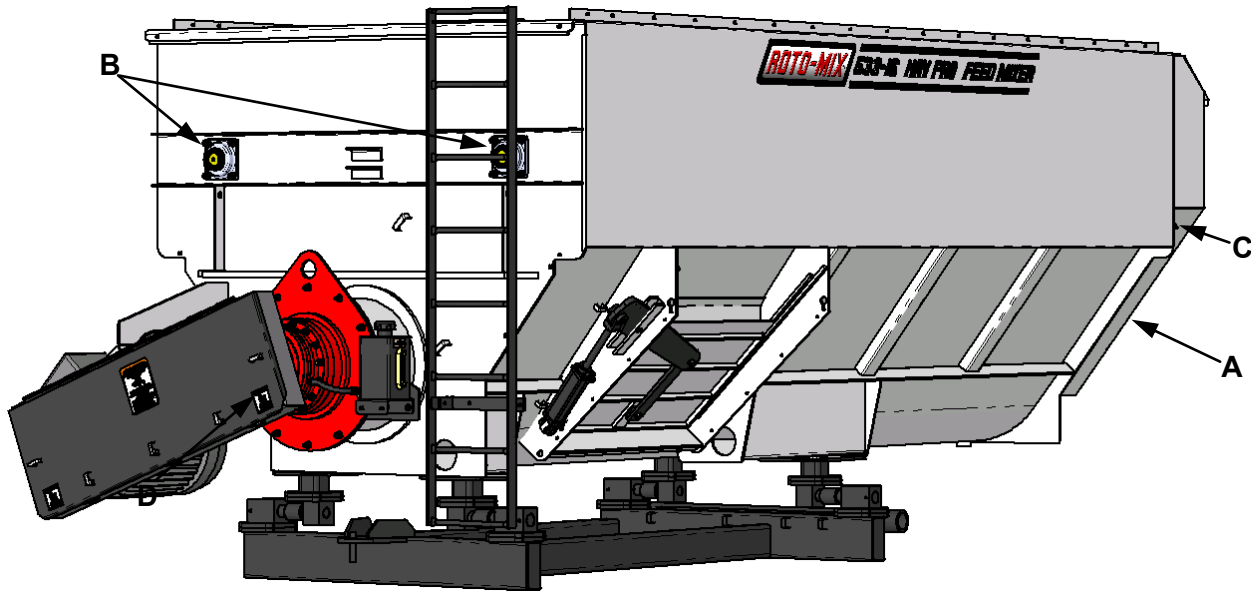

LOCATION	ITEM	LUBRICATION	INTERVAL
A	Rear Drive Oil Bath	SAE 30. Approximately 10 Gallon Capacity.	Check every 60 days. Keep filled to sight plug. Change if contaminated.
B	Front Bearings	Standard All Purpose Grease	Every 100 hours. Do not over grease bearings, as this can cause premature bearing failure by allowing containments
C	Bearings In Rear Drive	Standard All Purpose Grease	Every 100 hours for each grease zerk in the grease bank. Do not over grease bearings, as this can cause premature bearing failure by allowing containments into the bearing past the seal.
D	Gearbox	Synthetic Gear Lube 75W-90	After first 100 hours of operation, drain the oil. Flush gear case with an approved nonflammable, nontoxic solvent and refill with oil. thereafter oil should be changed every 2000 hours or 12 months. Oil level should be kept at the center of the sight gauge on the reservoir.

TROUBLE SHOOTING

⚠ WARNING

ALWAYS DISCONNECT OR DISENGAGE POWER BEFORE CLEANING, ADJUSTING, LUBRICATING OR SERVICING THIS MACHINE. FAILURE TO HEED MAY RESULT IN SERIOUS PERSONAL INJURY OR DEATH.

NOTE: CHART NOT ALL INCLUSIVE OF PROBLEMS. CONTACT DEALERSHIP FOR ASSISTANCE.

PROBLEM	POSSIBLE CAUSE	POSSIBLE REMEDY
Drive Belts Slipping	Worn or glazed belts.	Replace v-belts.
	Improper tensioning of v-belts.	Tension v-belts according to instructions on pages 22 & 23.
	Worn belt pulleys.	Replace pulleys.
Vibration Or Growling In Rear Structure	Drive sprockets out of line	Check and realign.
	Worn out bearing.	Replace bearing.
Chains Jumping Sprocket Teeth	Idler springs loose.	Adjust idlers as instructed on page 17.
	Drive sprockets out of line.	Check and realign.
	Worn sprocket teeth.	Replace sprocket.
Drive Chains Breaking	Sprocket misalignment.	Align sprockets.
	Usually causes side barb breakage due to chain riding up on sprocket teeth.	See possible remedies to “chains jumping sprocket teeth” above.
	Excessive loads.	Refer to general information about machine loading.
Excessive Bearing Failure	Improper lubrication.	Refer to lubrication chart.
	Contamination	Check seal.
	Excessive loads.	Refer to general information about machine loading.

V-BELT TENSIONING INSTRUCTIONS

V-belt tensioning adjustment can be made using a tension meter or other type spring scale, using the following procedure. After seating the belts in the groove and adjusting center distance so as to take up slack in the belts, further increase the tension until only a slight bow on the slack side is apparent while the drive is operating under load. Stop the drive, and using the meter, measure the force necessary to depress one of the center belts $1/64$ -inch for every inch of belt span (see sketch below). For example, a deflection for a 50-inch belt span is $50/64$ ths, or $25/32$ -inch. The amount of force required to deflect the belt should compare with the deflection forces noted in the chart on the next page. Also notice for V-belts that deflection forces vary from the initial "run-in" values which are greater (reflecting higher run-in tensioning) to the "normal" values for after the run-in

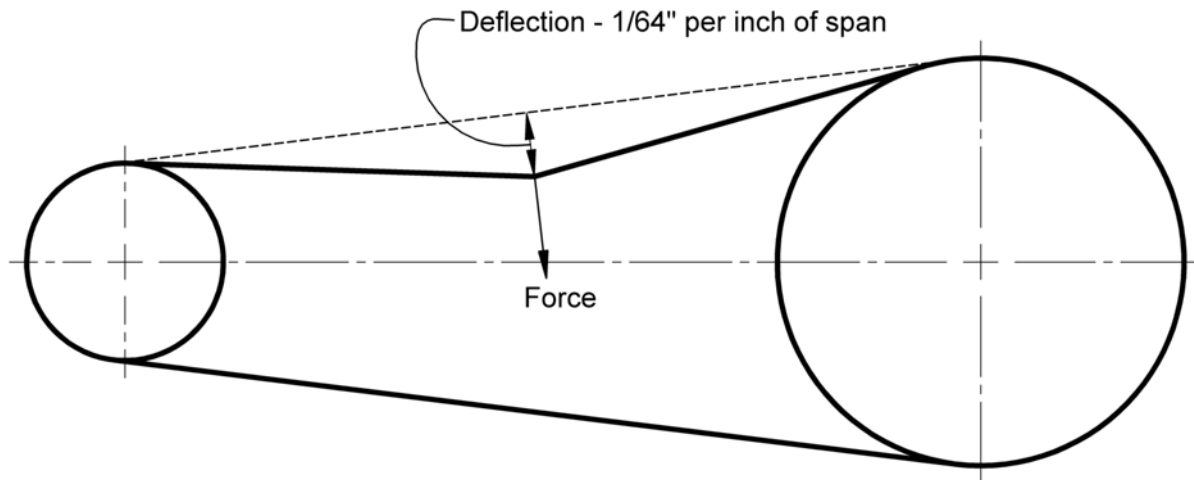

Standard V-Belt Tensioning Deflection Force (Single Belt)

Belt	Smaller Pulley	Deflection Force	
		Run-in (lbs.) (New Belt)	Normal (lbs.) (Used Belt)
A	3.0 - 3.6	3-3/8	2-1/4
	3.8 - 4.8	4-1/4	2-7/8
	5.0 - 7.0	5-1/8	3-3/8
AX	3.0 - 3.6	4-1/8	2-3/4
	3.8 - 4.8	5	3-1/4
	5.0 - 7.0	6	4
B	3.4 - 4.2	4	2-5/8
	4.4 - 5.2	6	4
	5.4 - 9.4	7-1/8	5-1/4
BX	3.4 - 4.2	5-1/4	3-1/2
	4.4 - 5.2	7-1/8	4-3/4
	5.4 - 9.4	9	6
C	7.0 - 9.0	11-1/4	7-1/2
	9.5 - 16.0	15-3/4	10-1/2
CX	7.0 - 9.0	13-1/2	9
	9.5 - 16.0	17-1/2	11-3/4
D	12.0 - 16.0	24-1/2	16-1/2
	18.0 - 22.0	33	22
E	21.6 - 27.0	48	32
3V	3.40 - 4.20	6	4
	4.20 - 10.6	7	5
3VX	2.20 - 3.65	7	5
	4.12 - 10.6	8	6
5V	7.10 - 10.9	16	8 - 12
	11.8 - 16.0	20	10 - 5
5VX	4.40 - 10.9	18	10 - 14
	11.8 - 16.0	22	12 - 18
8V	12.5 - 17.0	36	18 - 27
	18.0 - 22.4	40	20 - 30

Note: The force in the table above is shown per a single rib v-belt, for banded v-belts such as for a 2-rib v-belt you must multiply the force in the table for a single v-belt by 2 and for a 3-rib v-belt you must multiply the force in the table for a single v-belt by 3 and so on.

This Page intentionally left blank.

PART PAGES

TABLE OF CONTENTS

	PAGE NO.
STATIONARY AUGER ASSEMBLY & ROTOR ASSEMBLY	26
STATIONARY DRIVE ASSEMBLY	27
STATIONARY ELECTRIC DRIVE COMPONENTS	28-29
STATIONARY DISCHARGE PARTS	30
STATIONARY DISCHARGE DOOR HYDRAULIC POWER UNIT	31
STATIONARY SCALE FRAME ASSEMBLY	32
OIL BATH DOOR GROUP	33

533-16 STATIONARY AUGER ASSY & ROTOR ASSY

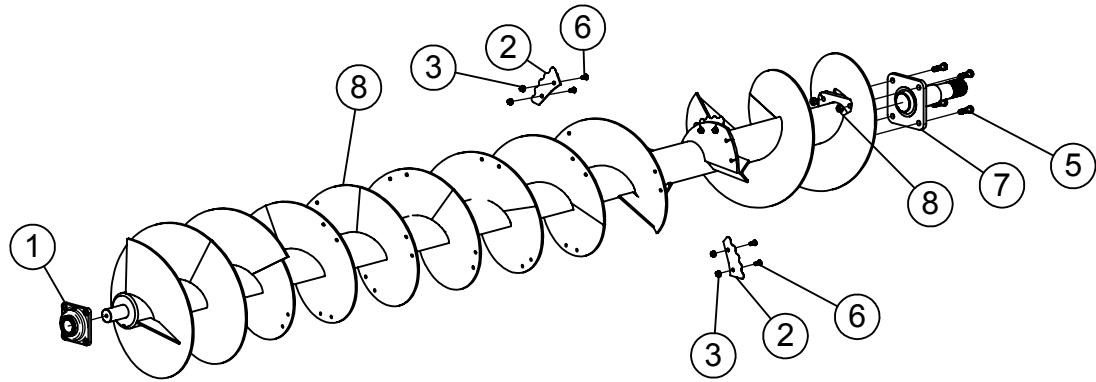

ITEM #	PART #	DESCRIPTION	QTY.
1	340439	BEARING, 2 7/16" FLANGE, RCJC	1
2	385006	AUGER KNIFE 8", LEFT HAND (OPTIONAL PARTS)	AN
3	400114	HEX NUT, 1/2"-13 SERRATED FLANGE #5 PLTD	AN
4	400912	HEX CROWN LOCK NUT 3/4"-10 #5 PLTD	4
5	406481	HEX BOLT, 3/4-10 x 2-1/2 #8 PITD HHCS	4
6	407553	Socket Flat Hd Cs, 1/2" X 2"	AN
7	850523	184 Rotor Shaft Flange WA	1
8	875368	533-653 Top Auger WA	1

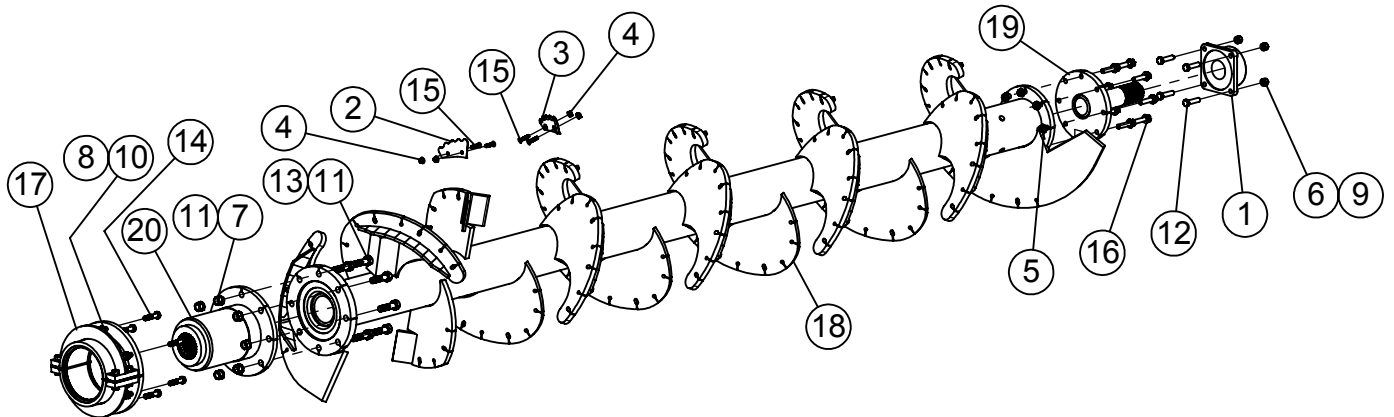

ITEM #	PART #	DESCRIPTION	QTY.
1	342056	BEARING, 3-1/2", 4-BOLT FLANGE	1
2	385015	LH AUGER KNIFE BLADE **FLAT**	AN
3	385016	RH AUGER KNIFE BLADE **FLAT**	AN
4	400114	HEX NUT, 1/2"-13 SERRATED FLANGE #5 PLTD	AN
5	400116	HEX NUT, 3/4"-10 SERRATED FLANGE #5 PLTD	8
6	400212	HEX NUT 3/4"-10 #5 PLTD	4
7	400216	Hex Nut 1"-8 #5 PLTD	8
8	400512	HEX NUT 3/4"-16 #8 PLTD	6
9	402012	SPRING LOCK WASHER 3/4" PLTD	4
10	402112	LOCK WASHER, EXTERNAL STAR 3/4"	6
11	402116	1" STAR LOCK WASHER	16
12	405783	HHCS 3/4-10 x 3" #5 PLTD	4
13	406528	HHCS 1"-8 x 3-3/4" #8 PLTD	8
14	406783	HHCS 3/4"-16 x 3" #8 PLTD	6
15	407556	Socket Flat Hd Cs, 1/2" X 2"	AN
16	407944	HHCS, 3/4"-10 x 3" SERRATED FLANGE #8 PLTD	8
17	872037	NYLATRON BEARING ASSY 9 3/4"	1
18	875530	533-653 Rotor WA 8-Bolt	1
19	875550	653 ROTOR REAR SHAFT WA (NYL) 8-BOLT	1
20	875553	653 STAT ROTOR DRIVE FLANGE WA	1

533-16 STATIONARY DRIVE ASSEMBLY

NOTE: BACK END OF OIL BATH IS NOT SHOWN FOR BETTER VISIBILITY.

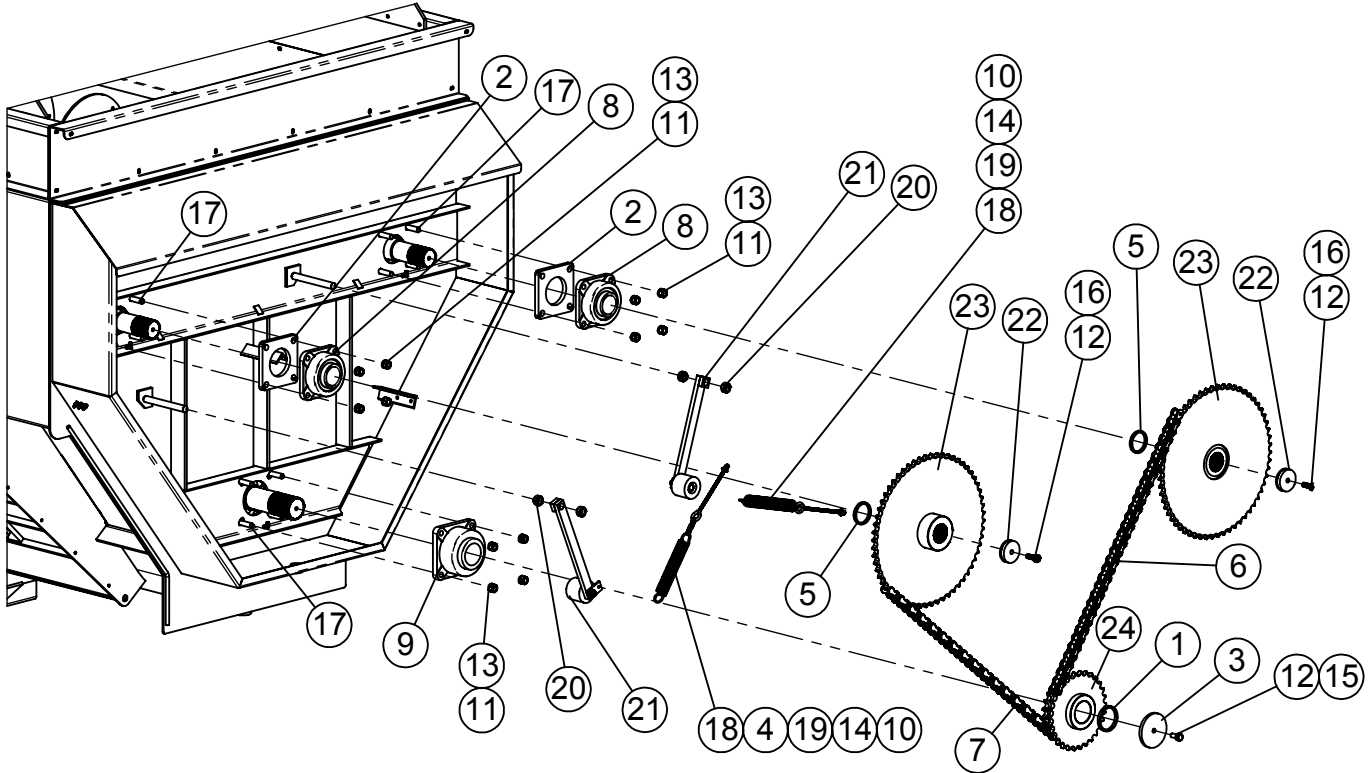

ITEM #	PART #	DESCRIPTION	QTY
1	150353	SHAFT SPACER, 3-1/2" x 7/16"	1
2	171338	3" BEARING SPACER	2
3	185261	WASHER 5 1/2" O.D.	1
4	185488	CHAIN-2/0 PASSING LINK	1
5	189546	3" x 3/8" SHAFT SPACER	2
6	321116	PITCH - COMPLETE #100 RC x116	1
7	321120	PITCH - COMPLETE #100 RC x120	1
8	340548	BEARING 3" 4-BLT FLANGE, BALL MSF-48	2
9	342056	BEARING, 3-1/2", 4-BOLT FLANGE	1
10	400206	HEX NUT 3/8"-16 #5 PLTD	4
11	400212	HEX NUT 3/4"-10 #5 PLTD	12
12	402010	SPRING LOCK WASHER 5/8" PLTD	3
13	402012	SPRING LOCK WASHER 3/4" PLTD	12
14	402406	FLAT WASHER 3/8" PLTD	2
15	405752	HHCS, 5/8"-11 x 1-1/2" #5 PLTD	1
16	405754	HHCS, 5/8"-11 x 2" #5 PLTD	2
17	405783	HHCS 3/4-10 x 3" #5 PLTD	12
18	410012	PULL SPRING 1-3/4" x 7"	2
19	410852	EYE BOLT 3/8" X 8"	2
20	412416	SET COLLAR 1" PLTD	4
21	770566	CHAIN IDLER ASSEMBLY x 18"	2
22	850129	END CAP W.A. - 3 1/2"	2
23	874030	100 B 60 x 3" SPL SPKT W.A.	2
24	875369	100A30 x 100A24 SPRKT W.A.	1

533-16 STATIONARY ELECTRIC DRIVE COMPONENTS

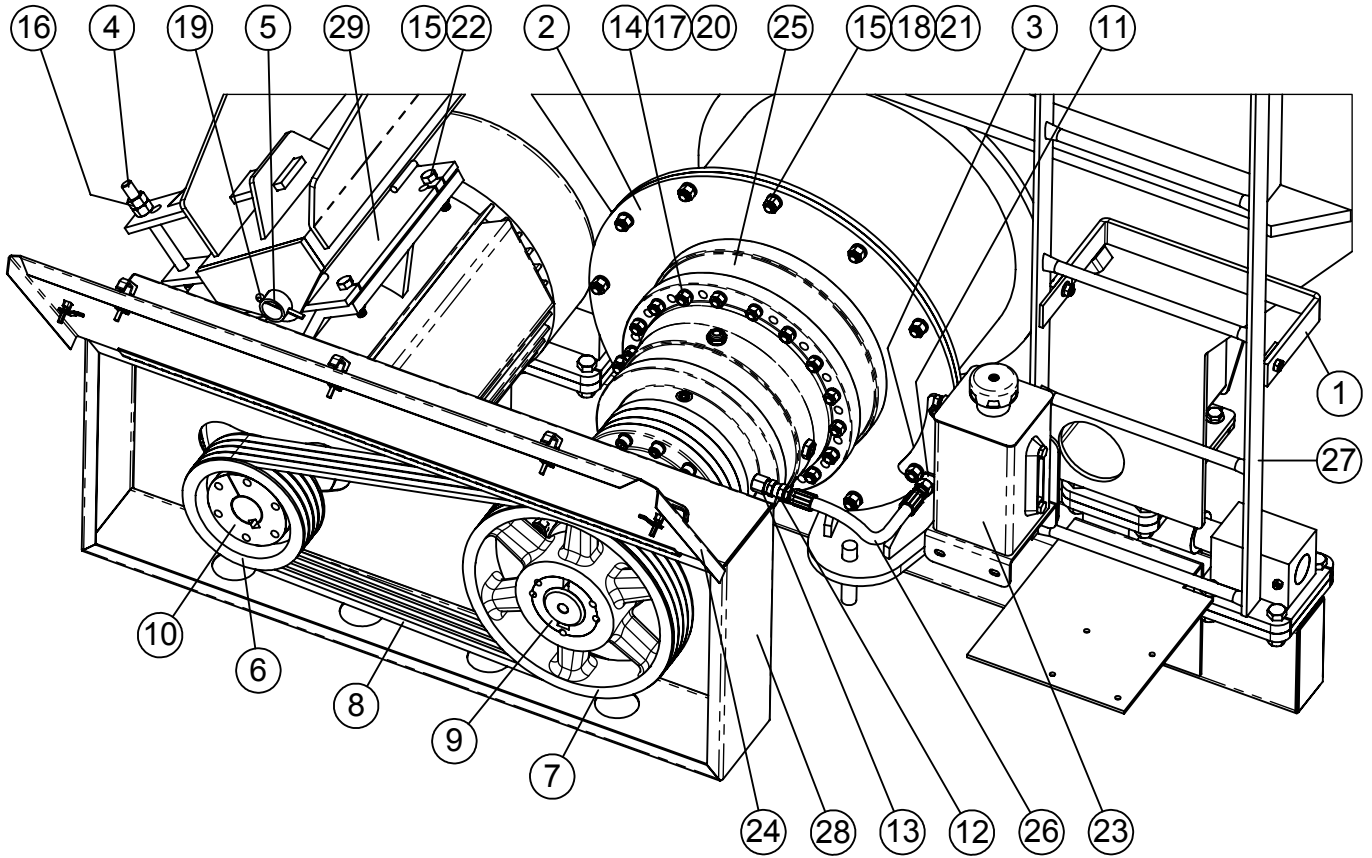

533-16 STATIONARY ELECTRIC DRIVE COMPONENTS

ITEM #	PART #	DESCRIPTION	QTY.
1	171883	LOWER STAT LADDER BRKT	1
2	875567	GEAR BOX MOUNT PLATE WA	1
3	171967	RESERVOIR MOUNT PLATE	1
4	185106	ADJUSTING ALL THREAD, 3/4"-10 x 8-3/4"	1
5	185645	720 MOTOR PIVOT PIPE	1
6	324027	SHEAVE 5V-4 GRV 9.25E	1
7	324039	SHEAVE, 5V-4 16" TL 3535	1
8	325106	5VX-1060 V-BELT	3
9	336041	BUSHING, SF 2-1/2"	1
10	336050	QD BUSHING, SF x 65mm	1
11	368031	HYD SWIVEL 1/2" MP x 1/2" FP 90°	1
12	368111	STRAIGHT ADAPTER 1/2" x 1/2"FP SWIVEL	1
13	368218	STRAIGHT, 1/2BSPPPP x 1/2FP	1
14	400209	HEX NUT, 9/16"-12, USS #5 Pltd	18
15	400210	HEX NUT 5/8"-11 #5 PLTD	20
16	400212	HEX NUT 3/4"-10 #5 PLTD	4
17	402009	SPRING LOCK WASHER, 9/16" PLTD	18
18	402010	SPRING LOCK WASHER 5/8" PLTD	16
19	404010	COTTER PIN 5/16" x 3" PLTD	2
20	405741	HHCS, 9/16-12 x 6-1/2, #5 PLTD	18
21	405754	HHCS, 5/8"-11 x 2" #5 PLTD	12
22	405756	HHCS, 5/8"-11 x 2-1/2" #5 PLTD	4
23	670168	OVERHUNG ADAPTER RESERVOIR KIT	1
24	770309	553 ELEC BELT SHLD DR ASSY	1
25	344050	553 STAT GEARBOX ET3255	1
26	781634	HOSE ASSY, 3/8" x 19", 1/2"MP x 3/8"MP	1
27	875415	1023 TRL LADDER WA	1
28	875475	HAYPRO BELT SHEL D WA	1
29	872724	920 ELECT MTR BASE WA	1

533-16 DISCHARGE DOOR PARTS

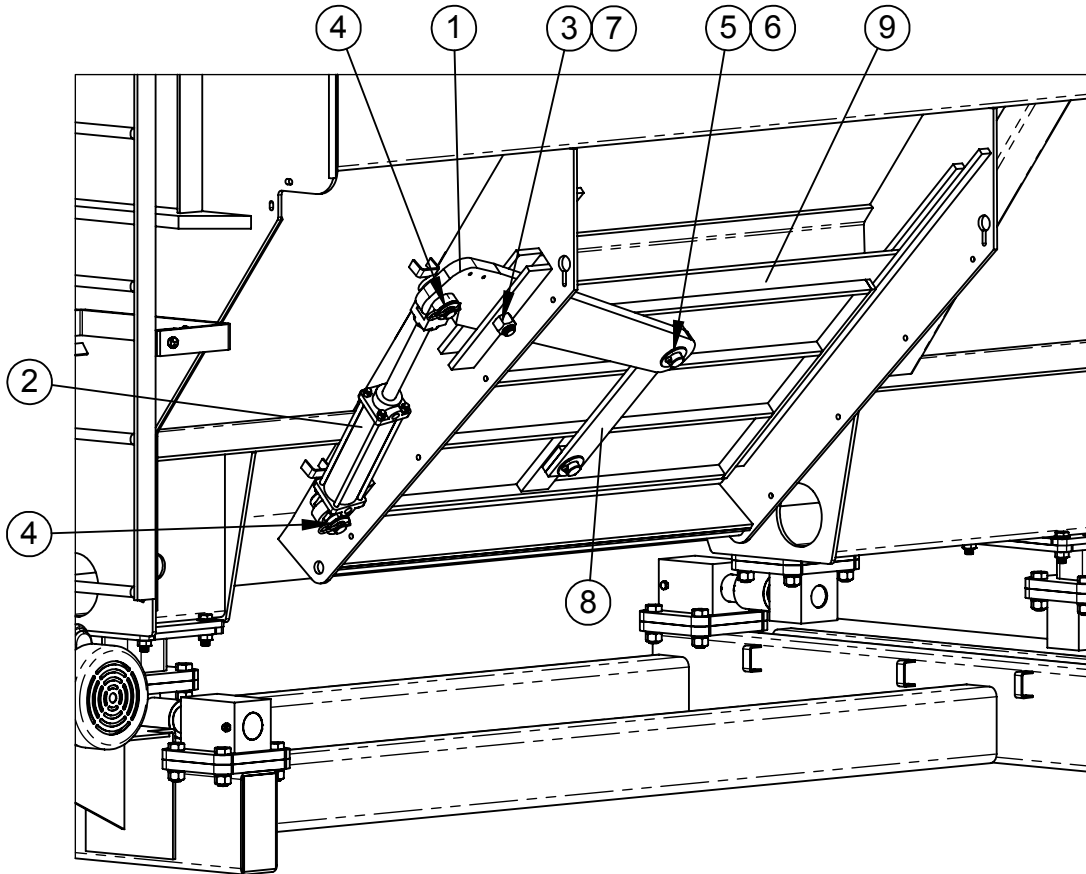

ITEM #	PART #	DESCRIPTION	QTY.
1	171173	DOOR PIVOT BAR - 38 1/4"	1
2	364057	HYD. CYL. 20-1/4 CC 2-1/2" x 8"	1
3	400916	HEX CROWN LOCKNUT, 1"-8 #5 PLTD	1
4	402516	WASHER FLAT, 1" SAE PLTD	2
5	402518	WASHER FLAT, 1-1/8" SAE PLTD	2
6	404000	COTTER PIN 1/4" x 1 1/2"	2
7	405832	HHCS 1"- 8 x 3 1/2" #5 PLTD	1
8	872248	STRAIGHT DOOR ARM W.A.	1
9	875341SS	DISCHARGE DOOR W.A. SS	1

DISCHARGE DOOR, HYDRAULIC POWER UNIT, 110V AC #750129

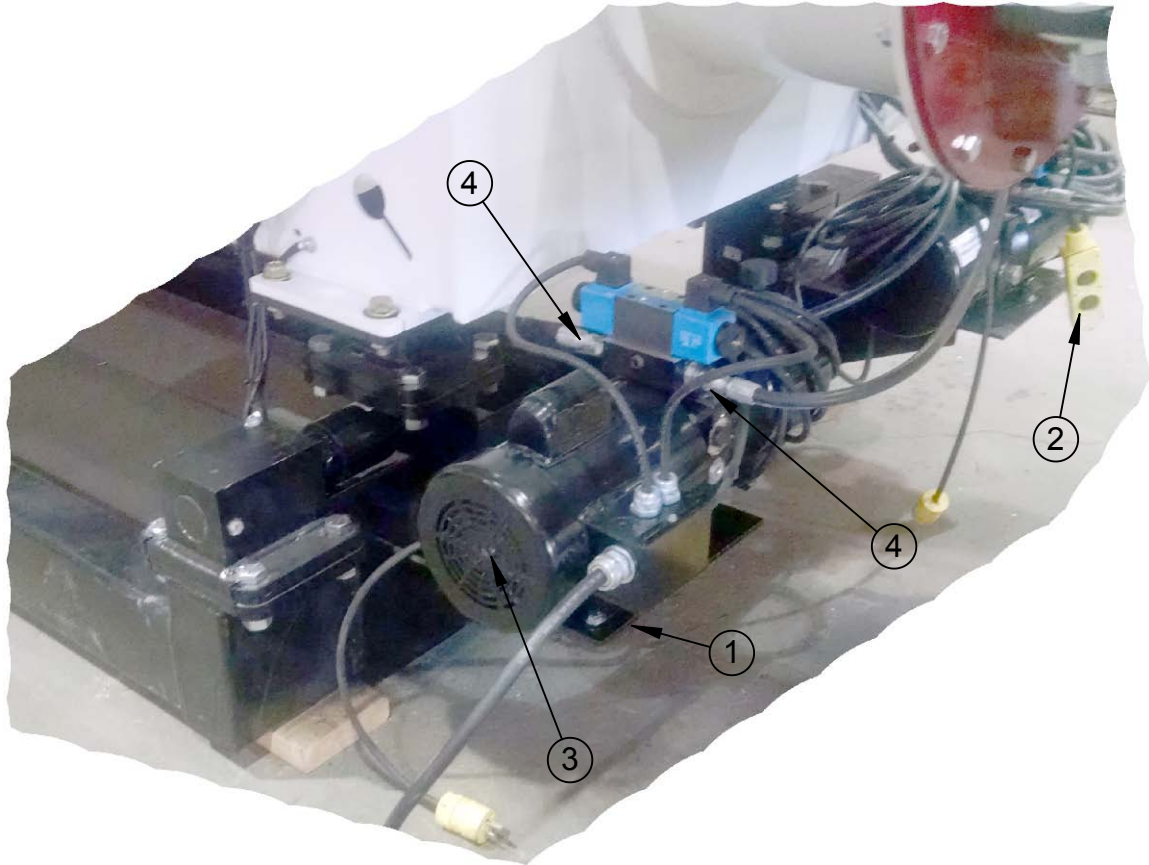

ITEM #	PART #	DECRPTION	QTY. PER UNIT
1	150914	Base-12", Power Unit	1 EA
2	357700	Switch-WH 4052 Pendant	1 EA
3	362151	Hyd Power Unit 110V Ac	1 EA
4	368115	Str 9/16MOR x 3/8FP Swivel	2 EA

533-16 STATIONARY SCALE FRAME ASSEMBLY

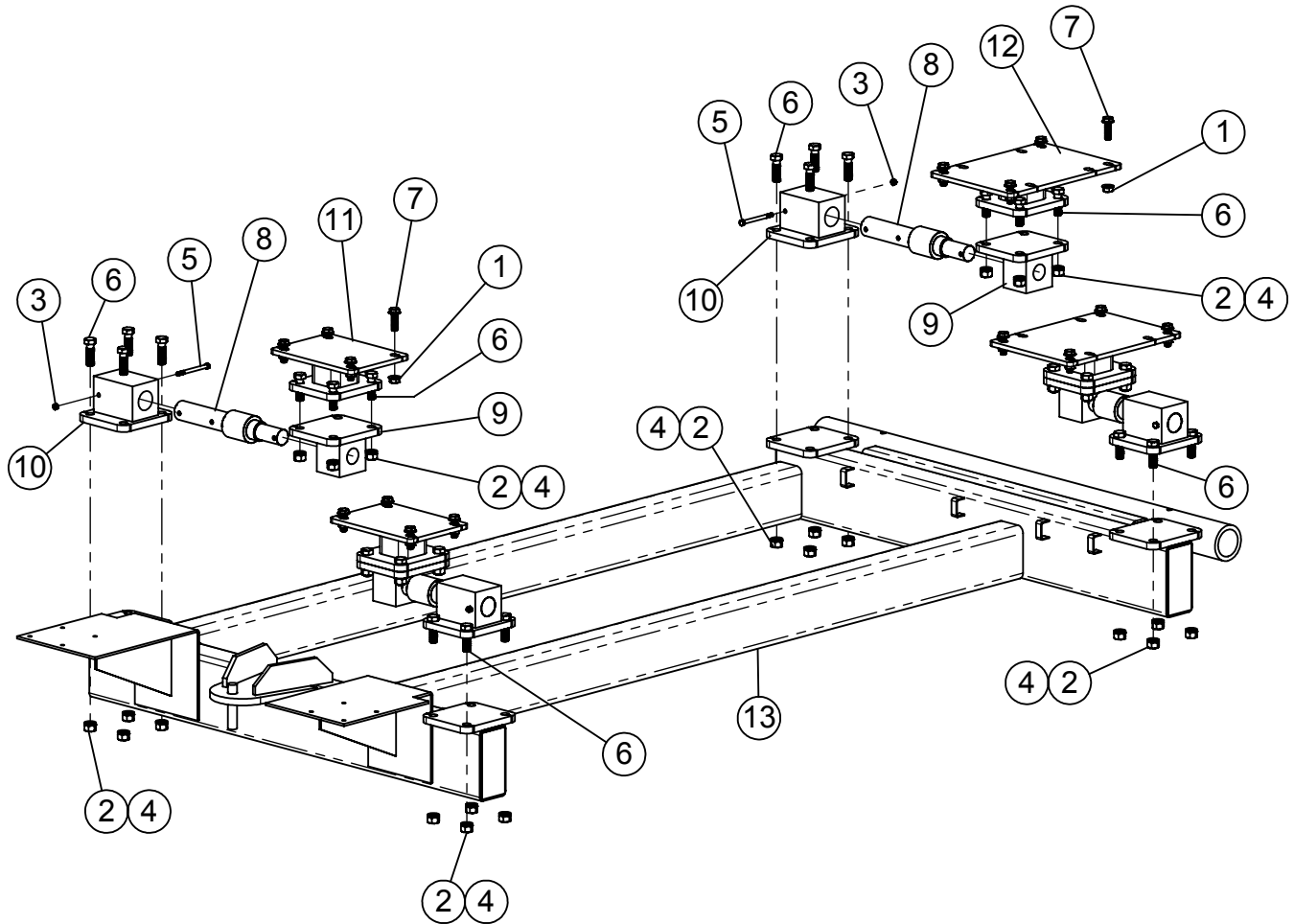

ITEM #	PART #	DESCRIPTION	QTY.
1	400115	HEX NUT, 5/8"-11 SER. FLANGE #5 PLTD	16
2	400212	HEX NUT 3/4"-10 #5 PLTD	32
3	400906	HEX NUT, 3/8"-16 CROWN LOC #5 PLTD	4
4	402012	SPRING LOCK WASHER 3/4" PLTD	32
5	405666	HHCS, 3/8"-16 x 4-1/2" #5 PLTD	4
6	405781	HHCS 3/4"-10 x 2-1/2" #5 PLTD	32
7	407923	HHCS 5/8"-11 x 2" SERRATED #5 PLTD.	16
8	450822	WEIGH BAR, 2-1/8"	4
9	860087	BAR END BLOCK WA, 2-1/8"	4
10	860088	BAR BLOCK WA, 2 1/8"	4
11	875473	HAYPRO STAT FRONT WEIGHBAR MOUNT WA	2
12	875474	HAYPRO STAT REAR WEIGHBAR MOUNT WA	2
13	875556	533/653 STATIONARY SCALE FRAME, LH DICCHARGE	1

533-16 OIL BATH DOOR GROUP

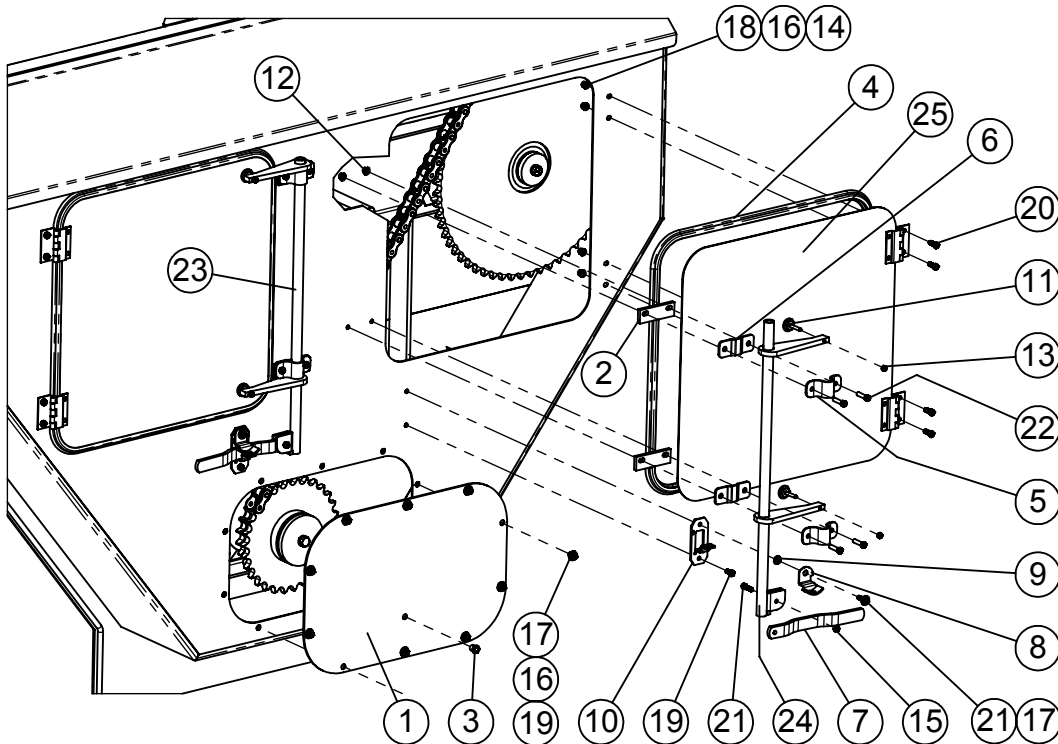

ITEM #	PART #	DESCRIPTION	QTY.
1	171307	LOWER OIL BATH DOOR- 17 1/2"x 26 1/2"	1
2	189503	CAM ROD SPACER	4
3	310720	Pipe Sight Plug, Pltd 3/8	1
4	351056	RUBBER BULB SEAL 5/32"	2
5	370316	CAM LOCK TOP PLATE	4
6	370317	CAM LOCK BOTTOM PLATE	4
7	370319	CAM LOCK HANDLE	2
8	370320	HANDLES CAM LOCK	2
9	370321	CAM LOCK BUSHING	2
10	370322	HANDLE STOP	2
11	370323	LEVELING PAD	4
12	400107	HEX NUT, 3/8"-16 SERRATED FLANGE #5 PLTD	12
13	400205	HEX NUT 5/16"-18 #5 PLTD	4
14	400206	HEX NUT 3/8"-16 #5 PLTD	8
15	400906	HEX NUT, 3/8"-16 CROWN LOC #5 PLTD	2
16	402006	WASHER SPRING LOCK 3/8" MED PLTD	18
17	402406	FLAT WASHER 3/8" PLTD	12
18	402506	FLAT WASHER 3/8" SAE PLTD	8
19	405652	HHCS 3/8"-16 x 3/4" #5 PLTD	12
20	405653	HHCS 3/8"-16 x 1" #5 PLTD	8
21	405654	HHCS 3/8"-16 x 1-1/4" #5 PLTD	4
22	405655	HHCS 3/8"-16 x 1 1/2" #5 PLTD	8
23	875363	L.H. CAM LOCK W.A.	1
24	875364	R.H. CAM LOCK W.A.	1
25	875366	533 - O. B. DOOR W.A.	2