



**FEED MIXER
524-15B**

**ASSEMBLY, OPERATION
AND PARTS MANUAL**

**ROTO-MIX
P.O. BOX 1724
2205 E. Wyatt Earp Blvd.
Dodge City, Kansas 67801
(620) 225-1142**

© ROTO-MIX 2006

SERIAL NUMBER _____

524-15 TABLE OF CONTENTS

PAGE NO.

WARRANTY-----	3
SCALES WARRANTY & SERVICE POLICY -----	4
OPERATOR QUALIFICATIONS -----	5
SAFETY INFORMATION -----	6-20
CHAIN TENSION & LOADING INSTRUCTIONS-----	21-23
LUBRICATION CHART -----	24
524-15 SPECIFICATIONS-----	25
PTO CHART -----	26
524-15 TRUCK DIMENSIONS -----	27
524-15 TRAILER DIMENSIONS -----	28
524-15 TRAILER DIMENSIONS W/CONVEYOR -----	29
524-15 STATIONARY DIMENSIONS-----	30
524-15 MOUNTING DIMENSIONS -----	31-32
524-15 PARTS TABLE OF CONTENTS-----	33



Limited Warranty Statement

ROTO-MIX LLC warrants to the original purchaser all products manufactured by it to be free from defects in material and workmanship under normal use and service.

ROTO-MIX's obligation under this warranty is limited to repairing or replacing, as the company may elect, free of charge and without charge for installation, at the place of business of a dealer or distributor authorized to handle the equipment covered by this warranty or at a ROTO-MIX facility, any parts that prove, in the company's judgment, to be defective in material or workmanship within one (1) year after delivery to the original purchaser, and still owned by the original purchaser. This warranty shall in no way make ROTO-MIX liable to anyone for personal injuries or damages, loss of time, or expense of any kind either direct or indirect resulting from part failure or defect. This warranty is subject to acts of God, fire and existing conditions of supply and demand, or production, or ability or inability to deliver, or for any other valid reason beyond the reasonable control of ROTO-MIX, to obtain materials, manufactured replacement parts, or make delivery thereof. No distributor, dealer, agent, or ROTO-MIX employee (other than the CEO or President in writing) is authorized to extend any other or further express or implied warranty or incur any additional obligation on ROTO-MIX's behalf in connection with the sale of this product.

If ROTO-MIX, or its duly authorized representative, shall find that such returned part or parts are defective and such defects, or defect, are included in and covered by said warranty, then such defective part or parts shall promptly be replaced without charge to the purchaser, F.O.B. the ROTO-MIX plant.

Product Registration - It is a condition of this warranty that the original purchaser must fill out the warranty card furnished by ROTO-MIX and that it be returned to ROTO-MIX within 10 days of purchase and be recorded in ROTO-MIX's owner file for this warranty to be valid. In the event an owner's card is not on file at the ROTO-MIX office, the warranty period will extend only from date equipment was picked up or shipped from the ROTO-MIX plant.

Maintenance - It is the customer's responsibility to maintain their equipment in accordance with the instructions provided in the Operator's Manual. ROTO-MIX recommends that you keep records and receipts; you may be asked to prove that maintenance instructions have been followed.

Operation - It is the customer's responsibility to operate the equipment only for the purpose for which it was designed and in accordance with all safety and operational recommendations contained in the Operators Manual. If a defect in materials or workmanship occurs, it is the customer's responsibility to cease operating the equipment until authorized repairs are made. **Damage, which occurs from continued operation, may not be covered by this warranty.**

What this Warranty Covers

This warranty covers failures caused by defects in materials or workmanship only.

This Warranty does not cover failures caused by:

- Improper operation
- Natural calamities
- Unauthorized modifications
- Unauthorized repairs
- Use of Non ROTO-MIX parts
- Neglected maintenance
- The use of PTO Shaft Adaptors
- Usage contrary to the intended purpose of the product

Warranty continues on the next page.

Limited Warranty Statement continued

This Warranty does not cover replacement of Wear or Maintenance Items including, but not limited to.

- Lubricants
- Filters
- Hoses
- Tires
- Augers
- Wipers
- Chains
- Idlers
- Batteries
- Blades
- Belts

This Warranty does not cover:

- Pickup and delivery of the equipment
- Service Calls or Travel Time to and from sites
- Rental of replacement equipment during repair period
- Products that have been declared a total loss and subsequently salvaged
- Overtime labor charges
- ROTO-MIX is not responsible and will not be liable for damage caused to persons or property, commercial loss, loss of time or production, loss of use by reason of the installation or use of ROTO-MIX products or their mechanical failure.

Right to Make Changes

ROTO-MIX reserves the right to make any changes to a ROTO-MIX product at any time without incurring any obligation with respect to any product previously ordered, sold or shipped, with or without notice.

Parts Warranty

ROTO-MIX warrants replacement parts against defects in materials or workmanship for a period of 90 days or the remainder of the product warranty, whichever is longer. Remedy for defective replacement parts for units that are beyond the original product warranty, will be limited to replacement of the failed part. Failures that are due to damage, improper installation, lack of maintenance or improper operation will not be covered.

ROTO-MIX 2205 East Wyatt Earp Blvd., Dodge City, KS 67801 (620) 225-1142 Fax: (620) 225-6370

SCALES WARRANTY & SERVICE POLICY

DIGI-STAR SCALE SYSTEMS

Digi-Star, LLC warrants for a period of one year from date of installation, to correct by repair or replacement, at Digi-Star's option, any defect in material or workmanship in any part of this product. In the event of replacement, Digi-Star's sole obligation shall be to provide replacement products or parts. F.O.B. Digi-Star, LLC, W5527 Hwy 106, Fort Atkinson, WI 53538 USA.

WEIGH-TRONIX SCALE SYSTEMS

WEIGH-TRONIX warrants for a period of one year from date of installation, to correct by repair or replacement, at Weigh-Tronix's option, any defect in material or workmanship in any part of this product. In the event of replacement, Weigh-Tronix's sole obligation shall be to provide replacement products or parts. F.O.B. Avery Weigh-Tronix, 1000 Armstrong Drive, Fairmont, MN 56031-1439 USA.

OPERATOR QUALIFICATIONS

Operation Of this mixer/feeder shall be limited to competent and experienced persons. In addition, anyone who will operate or work around a mixer/feeder must use good common sense. In order to be qualified, he or she must also know and meet all other qualifications, such as:

1. Some regulations specify that no one under the age of sixteen (16) may operate power machinery. It is your responsibility to know what these regulations are in your area and/or situation.
2. Current OSHA regulations state in part: At the time of initial assignment and at least annually thereafter, the employer shall instruct **EVERY** employee in the safe operation and servicing of all equipment with which the employee is, or will be involved.
3. Unqualified persons are to **STAY OUT OF THE WORK AREA.**
4. A person who has not read and understood all operating and safety instructions is not qualified to operate the machinery.

FAILURE TO READ THIS MIXER/FEEDER MANUAL AND ITS SAFETY INSTRUCTIONS IS A MISUSE OF THE EQUIPMENT.



SAFETY

TAKE NOTE! THIS SAFETY ALERT SYMBOL FOUND THROUGHOUT THIS MANUAL IS USED TO CALL YOUR ATTENTION TO INSTRUCTIONS INVOLVING YOUR PERSONAL SAFETY AND THE SAFETY OF OTHERS. FAILURE TO FOLLOW THESE INSTRUCTIONS CAN RESULT IN INJURY OR DEATH.



THIS SYMBOL MEANS

-ATTENTION!

-BECOME ALERT!

-YOUR SAFETY IS INVOLVED!

SIGNAL WORDS: Note the use of the signal words **DANGER**, **WARNING**, and **CAUTION** with the safety messages. The appropriate signal word for each has been selected using the following guidelines:

DANGER: Indicates an imminently hazardous situation that, if not avoided, will result in serious injury or death. This signal word is to be limited to the most extreme situations typically for machine components which, for functional purposes, cannot be guarded.

WARNING: Indicates a potentially hazardous situation that, if not avoided, will result in serious injury or death, and includes hazards that are exposed when guards are removed. It may also be used to alert against unsafe practices.

CAUTION: Indicates a potentially hazardous situation that, if not avoided, may result in minor or moderate injury. It may also be used to alert against unsafe practices.

If you have questions not answered in this manual or require additional copies or the manual is damaged, please contact your dealer or ROTO-MIX, 2205 E. Wyatt Earp, Dodge City, Kansas, 67801. (Telephone) 620-225-1142 (Fax) 620-225-6370

SAFETY FIRST

REMEMBER: The careful operator is the best operator. Most accidents are caused by human error. Certain precautions must be observed to prevent the possibility of injury or death.



DO NOT ALLOW PERSONNEL OTHER THAN THE QUALIFIED OPERATOR NEAR THE MACHINE.



NEVER START MACHINE UNTIL ALL GUARDS AND SAFETY SHIELDS ARE IN PLACE.



DO NOT CLEAN, ADJUST OR LUBRICATE THE MACHINE WHILE IT IS IN MOTION.



BEFORE STARTING TRACTOR ENGINE, BE SURE PTO SHIELDS TURN FREELY.



LOOSE OR FLOPPY CLOTHING SHOULD NOT BE WORN BY THE OPERATOR.

OPERATING PRECAUTIONS & INSTRUCTIONS:

- A. Check to see that no obstructions are present in the mixer prior to start up.
- B. Before loading, run the mixer empty and check all operations.
- C. Do not overload the mixer, as the mixing efficiency may be reduced and unit damage may occur. (See loading instructions).
- D. Remove all moisture drain plugs if the mixer is going to set in the rain or snow.
- E. Be sure all shields are in place before operation.
- F. Use common sense when operating.



EQUIPMENT SAFETY GUIDELINES

Safety of the operator is one of the main concerns in designing and developing a new piece of equipment. Designers and manufactures build in as many safety features as possible. However, every year many accidents occur which could have been avoided by a few seconds of thought and a more careful approach to handling equipment. You, the operator, can avoid many accidents by observing the following precautions in this section. To avoid personal injury, study the following precautions and insist those working with you, or for you, follow them.

In order to provide a better view, certain photographs or illustrations in this manual may show an assembly with a safety shield removed. However, equipment should never be operated in this condition. Keep all shields in place. If shield removal becomes necessary for repairs, replace the shield prior to use.

Replace any CAUTION, WARNING, DANGER or instruction safety decal that is not readable or is missing. Location of such decals are indicated in this manual.

Do not attempt to operate this equipment under the influence of drugs or alcohol.

Review the safety instructions with all users annually.

This equipment is dangerous to children and persons unfamiliar with its operation. The operator should be a responsible adult familiar with farm machinery and trained in this equipment's operations. Do not allow persons to operate or assemble this unit until they have read this manual and have developed a thorough understanding of the safety precautions and of how it works.

To prevent injury or death, use a tractor equipped with a Roll Over Protective System (ROPS). Do not paint over, remove or deface any safety signs or warning decals on your equipment. Observe all safety signs and practice the instructions on them.

Never exceed the limits of a piece of machinery. in its ability to do a job, or to do so safely, is in question - DON'T TRY IT.



LIGHTING AND MARKING

It is the responsibility of the customer to know the lighting and marking requirements of the local highway authorities and to install and maintain the equipment to provide compliance with the regulations. Add extra lights when transporting at night or during periods of limited visibility.



KEEP ALL SHIELDS IN PLACE

Do not operate mixer/feeder without safety shields in place.

Rotating parts can crush or dismember causing personal injury or death.

Disconnect PTO driveline before removing shields for adjustment or service.

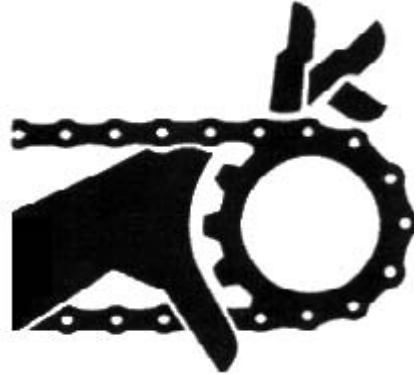

OPERATE MIXER/FEEDER SAFELY

Rotating parts can entangle or strike people, resulting in personal injury or death.

Never enter a mixer/feeder while in operation.

Operate the mixer/feeder from the operator's seat only.

Do not exceed load capacity of the mixer/feeder. (See loading instructions).

Reduce speed when turning or traveling on rough terrain.

Avoid traveling over loose fill, rocks, ditches or holes.

Keep transmissions in gear when traveling downhill.



KEEP RIDERS OFF MIXER/FEEDER

Keep riders off.

Riders are subject to injury such as being struck by foreign objects and being thrown off. Riders also obstruct the operator's view resulting in the machine being operated in an unsafe manner.





STAY CLEAR OF ROTATING DRIVELINES

Entanglement in rotating driveline can cause serious injury or death.

Keep tractor master shield and driveline shields in place at all times. Make sure rotating shields turn freely.

Wear close fitting clothing. Stop the engine and be sure PTO driveline is stopped before making adjustments, connections, or cleaning out PTO driven equipment .



PREVENT BATTERY EXPLOSIONS

Keep sparks, lighted matches, and open flame away from the top of battery. Battery gas can explode.

Never check battery charge by placing a metal object across the posts. Use a volt-meter or hydrometer.

Do not charge a frozen battery; it may explode. Warm battery to 16C (60F)



AVOID HIGH-PRESSURE FLUIDS

Escaping fluid under pressure can penetrate the skin causing serious injury or death.

Avoid the hazard relieving pressure before disconnecting hydraulic or other lines. Tighten all connections before applying pressure.

Search for leaks with a piece of cardboard. Protect hands and body from high pressure fluids.

If an accident occurs, see a doctor immediately. Any fluid injected into the skin must be surgically removed within a few hours or gangrene may result. Doctors unfamiliar with this type of injury should reference a knowledgeable medical source.





PREPARING TRACTOR FOR TRAILER MIXER

POSITIONING DRAWBAR

IMPORTANT: Drive components can be damaged from excessive speed. Under no circumstances should a feed mixer equipped with 540 RPM be operated by a tractor with 1000 RPM PTO.

Feed mixers are available with either 540 or 1000 RPM driveline. Match tractor PTO with the feed mixer driveline.

IMPORTANT: To prevent driveline damage, adjust tractor drawbar to recommended setting. Disengage tractor PTO before turning.

Remove clevis if equipped. Turn offset drawbar down.

Adjust drawbar length:

PTO SPEED	DIMENSION (A)
540 RPM	14" (256 mm)
1000 RPM (1-3/8" - 21 SPLINE)	16" (406 mm)
1000 RPM 91-3/4" - 20 SPLINE	20" (508 mm)

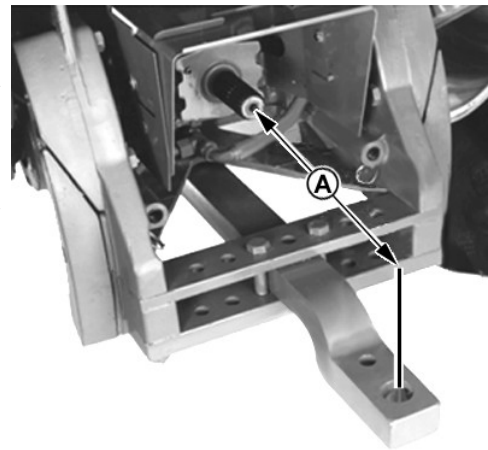

ADJUST TRAILER HITCH CLEVIS

Mixer should be approximately level when attached to tractor.

Adjust clevis by changing hole location on tongue.

Hitch Pin Size --- 1" x 7"

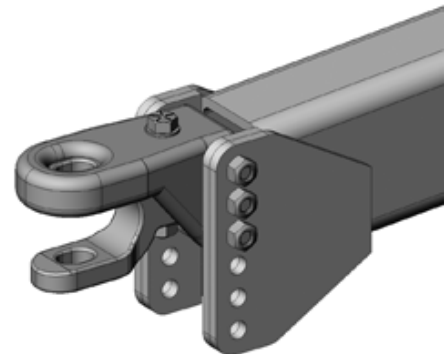

SAFETY SIGNS

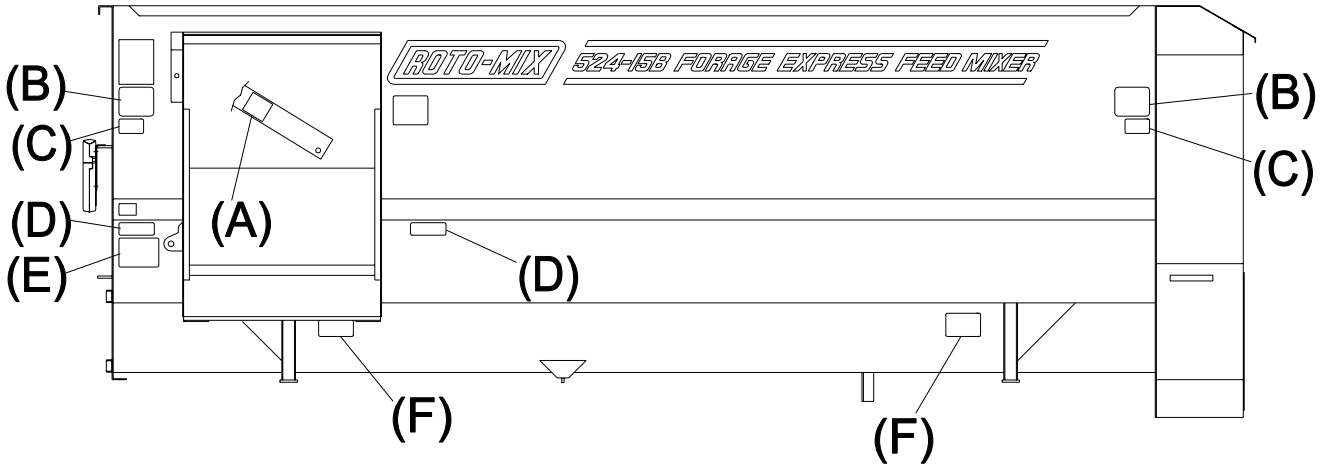

(A) 440833



(C) 440831



(E) 440819

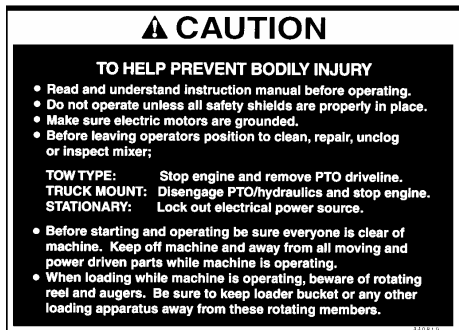

(B) 440827



(D) 440818



(F) 440826



SAFETY SIGNS

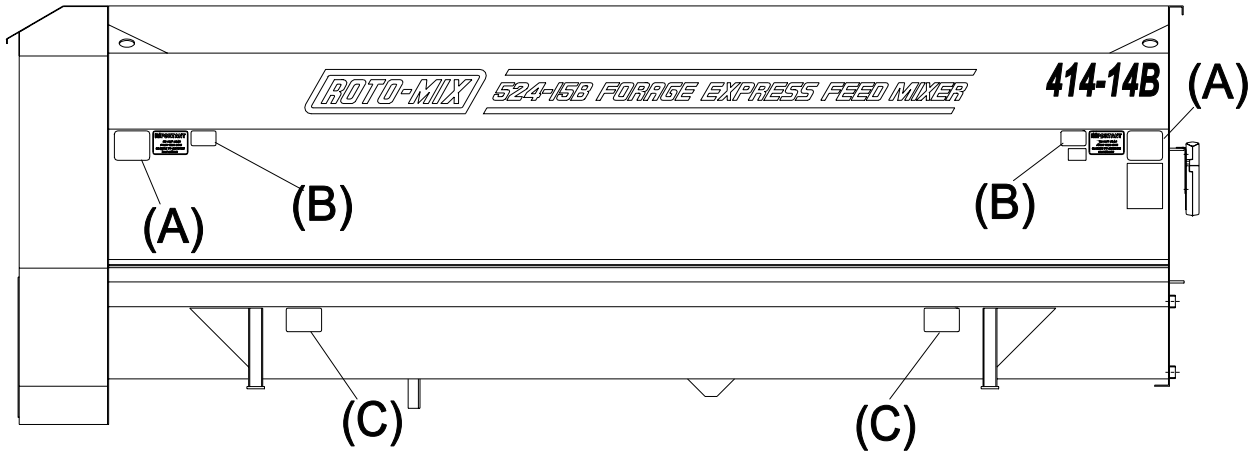

(B) 440831



(A) 440828



(C) 440826



SAFETY SIGNS

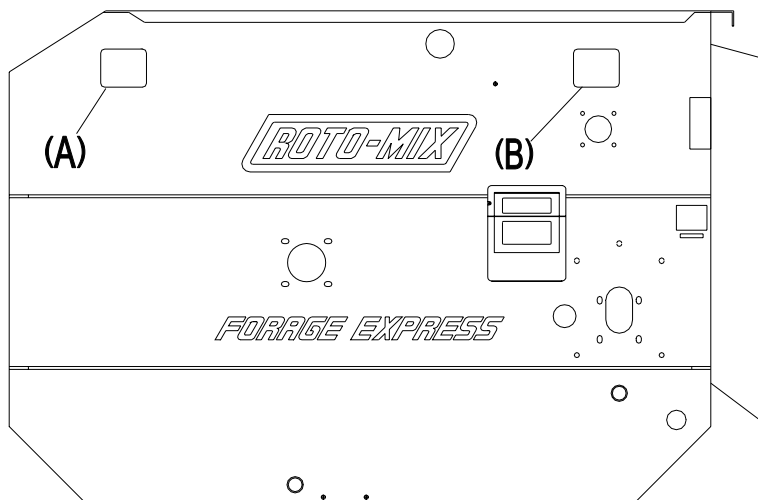

(A) 440828



(D) 440819

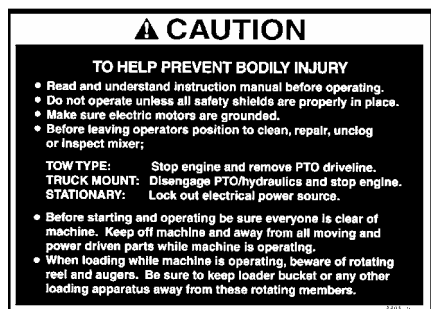

(B) 440827

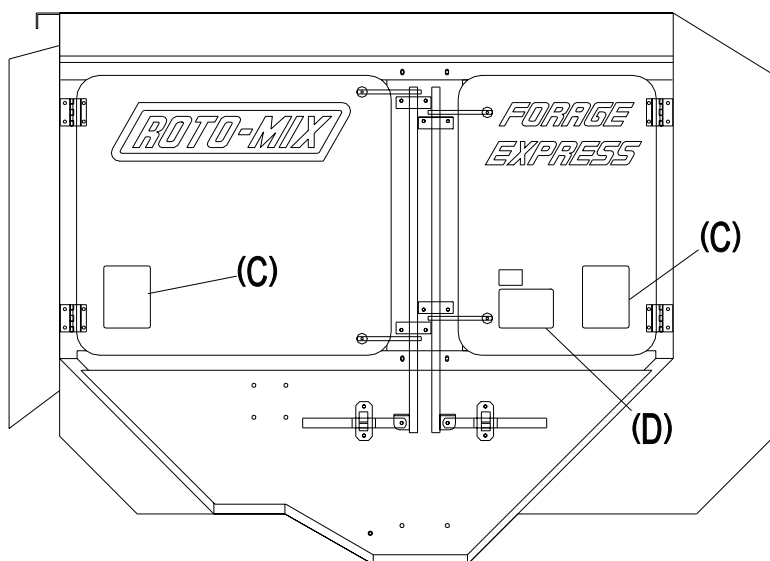

(C) 440822





SAFETY DECAL CARE



Keep safety decals and signs clean and legible at all times.

Replace safety decals and signs that are missing or have become illegible.

Replaced parts that displayed a safety sign should also display the current sign.

Safety decals or signs are available from your dealer or the ROTO-MIX manufacturing plant.

How to Install Safety Decals:

Be sure that the installation area is clean and dry.

Decide on the exact position before you remove the backing paper.

Remove the smallest portion of the split backing paper.

Align the decal over the specified area and carefully press the small portion with the exposed sticky backing in place.

Slowly peel back the remaining paper and carefully smooth the remaining portion of the decal in place.

Small air pockets can be pierced with a pin and smoothed out using the piece of decal backing paper.



REMEMBER

Your best assurance against accidents is a careful and responsible operator. If there is any portion of this manual or function you do not understand, contact your dealer or the ROTO-MIX plant.

BEFORE OPERATION:

Carefully study and understand this manual.

Do not wear loose-fitting clothing which may catch in moving parts.

Always wear protective clothing and substantial shoes.

Keep wheel lug nuts or bolts tightened to specified torque.

Assure that agricultural implement tires are inflated evenly.

Give the unit a visual inspection for any loose bolts, worn parts or cracked welds, and make necessary repairs. Follow the maintenance safety instructions included in this manual.

Be sure that there are no tools lying on or in the mixer/feeder.

Do not use the unit until you are sure that the area is clear, especially children and animals.

Because it is possible that this mixer/feeder may be used in dry areas or the presence of combustibles, special precautions should be taken to prevent fires and fire fighting equipment should be readily available.

Don't hurry the learning process or take the unit for granted. Ease into it and become familiar with your new mixer/feeder.

Practice operation of your mixer/feeder and its attachments. Completely familiarize yourself and other operators with its operation before using.

Securely attach to towing unit. Use a high strength, appropriately sized hitch pin with a mechanical retainer.

Do not allow anyone to stand between the tongue or hitch and the towing vehicle when backing up to the mixer/feeder.



DURING OPERATION:

Beware of bystanders, **particularly children!** Always look around to make sure that it is safe to start the engine of the towing vehicle or move the unit. This is particularly important with higher noise levels and quiet cabs, as you may not hear people shouting.

NO PASSENGERS ALLOWED - Do not carry passengers anywhere on, or in, the tractor or equipment, except as required for operation.

Keep hands and clothing clear of moving parts.

Do not clean, lubricate or adjust your mixer/feeder while it is moving.

Be especially observant of the operating area and terrain - watch for holes, rocks or other hidden hazards. Always inspect the area prior to operation.

Do not operate near the edge of drop-offs or banks.

Do not operate on steep slopes as overturn may result.

Operate up and down (not across) intermediate slopes. Avoid sudden starts and stops.

Pick the levellest possible route when transporting across fields. Avoid the edges of ditches or gullies and steep hillsides.

Be extra careful when working on inclines.

Periodically clear the equipment of brush, twigs or other materials to prevent buildup of dry combustible materials.

Maneuver the tractor or towing vehicle at safe speeds.

Avoid overhead wires or other obstacles. Contact with overhead lines could cause serious injury or death.

Avoid loose fill, rocks and holes; they can be dangerous for equipment operation or movement. Allow for unit length when making turns.

Do not walk or work under raised components or attachments unless securely positioned and blocked.

Keep all bystanders, pets and livestock clear of the work area.

Operate the towing vehicle from the operator's seat only.

Never stand alongside of the unit with engine running. Never attempt to start engine and/or operate machine while standing alongside of unit.



DURING OPERATION (CONT.)

Never leave running mixer/feeder unattended.

As a precaution, always recheck the hardware on mixer/feeder following every 100 hours of operation. Correct all problems. Follow the maintenance safety procedures.



FOLLOWING OPERATION:

Following operation, or when unhitching, stop the tractor or towing vehicle, set the brakes, disengage the PTO and all power drives, shut off the engine and remove the ignition keys.

Store the unit in an area away from human activity.

Do not park equipment where it will be exposed to livestock for long periods of time. Damage and livestock injury could result.

Do not permit children to play on or around the stored unit.

Make sure parked machine is on a hard, level surface and engage all safety devices.

Wheel chocks may be needed to prevent unit from rolling.



HIGHWAY AND TRANSPORT OPERATIONS:

Adopt safe driving practices:

Keep the brake pedals latched together at all times. **Never use independent braking with machine in tow as loss of control and/or upset of unit can result.**

Always drive at a safe speed relative to local conditions and ensure that your speed is low enough for an emergency stop to be safe and secure. Deep speed to a minimum.

Reduce speed prior to turns to avoid the risk of overturning.

Avoid sudden uphill turns on steep slopes.

Always keep the tractor or towing vehicle in gear to provide engine braking when going downhill. Do not coast.

Do not drink and drive.



HIGHWAY AND TRANSPORT OPERATIONS (CONT.):

Comply with state and local laws governing highway safety and movement of farm machinery on public roads.

Use approved accessory lighting flags and necessary warning devices to protect operators of other vehicles on the highway during daylight and nighttime transport.

The use of flashing amber lights is acceptable in most localities. However, some localities prohibit their use. Local laws should be checked for all highway lighting and marking requirements.

When driving the tractor and mixer/feeder on the road or highway under 20 MPH (40 KPH) at night or during the day, use flashing amber warning lights and a slow moving vehicle (SMV) identification emblem.

Plan your route to avoid heavy traffic.

Be a safe courteous driver. Always yield to oncoming traffic in all situations, including narrow bridges, intersections, etc.

Be observant of bridge loading ratings. Do not cross bridges rated lower than the gross weight at which you are operating.

Watch for obstructions overhead and to the side while transporting.

Always operate mixer/feeder in a position to provide maximum visibility at all times. Make allowances for increased length and weight of the mixer/feeder when making turns, stopping the unit, etc.



PERFORMING MAINTENANCE:

Good maintenance is your responsibility. Poor maintenance is an invitation to trouble.

Make sure there is plenty of ventilation. Never operate the engine of the towing vehicle in a closed building. The exhaust fumes may cause asphyxiation.

Before working on the mixer/feeder, stop the towing vehicle, set the brakes, disengage the PTO and all power drives, shut off the engine and remove the ignition keys.

Be certain all moving parts on attachments have come to a complete stop before attempting to perform maintenance.

Always use a safety support and block the wheels. Never use a jack to support the machine.



PERFORMING MAINTENANCE (CONT.):

Always use the proper tools or equipment for the job at hand.

Use extreme caution when making adjustments.

Never use our hands to locate hydraulic leaks on attachments. Use a small piece of cardboard or wood. Hydraulic fluid escaping under pressure can penetrate the skin.

When disconnecting hydraulic lines, shut off hydraulic supply and relieve all hydraulic pressure.

Openings in the skin and minor cuts are susceptible to infection from hydraulic fluid. If injured by escaping hydraulic fluid, see a doctor at once. Gangrene can result. Without immediate treatment, serious infection and reactions can occur.

Replace all shields and guards after servicing and before moving.

After servicing, be sure all tools, parts and service equipment are removed.

Do not allow grease or oil to build up on any step or platform.

Never replace hex bolts with less than grade five (5) bolts unless otherwise specified.

Where replacement parts are necessary for periodic maintenance and servicing, genuine factory replacement parts must be used to restore your equipment to original specifications. ROTO-MIX will not claim responsibility for use of unapproved parts and/or accessories and other damages as a result of their use.

If equipment has been altered in any way from original design, ROTO-MIX does not accept any liability for injury or warranty.

A fire extinguisher and first aid kit should be kept readily accessible while performing maintenance on this mixer/feeder.

READ THE FOLLOWING BEFORE WELDING ON THIS MIXER/FEEDER

When welding on your mixer/feeder, do not allow the current to flow through the ball bearings or the roller chains. Ground directly to the item being welded.

Always disconnect the scale instrumentation from the weigh bars or load cells and the power source. Be sure the current does not pass through weigh bars or load cells or scale indicator. The alternator should always be disconnected if the mixer/feeder is not disconnected from the towing vehicle.

CHAIN TENSION

All the single roller chain should be tightened to the point of .042" (1 mm) (dime) clearance is reached between the coils of the 1-1/4" idler tension springs and .068" (1.7 mm) (nickel) clearance is reached between the coils of the 1-3/4" idler tension springs.

LOADING INSTRUCTIONS & PRECAUTIONS

- A.** Do not add side board extensions to the mixer.
- B.** Do not overload the mixer. Mixer capacity can be reached by weight or volume. By volume, the rotor bars and wipers should always be visible at the peak of the rotor cycle. If the rotor is completely submerged under the mix, mixing efficiency may be reduced, spillage may occur, and damage to the mixer may result. Maximum capacity by weight can be calculated by multiplying 28 pounds times mixer cubic foot capacity.
- C.** Load molasses and/or liquid protein supplements first with mixer not running, then add one (1) commodity ingredient before starting the mixer. For the shortest mixing time and maximum mixing efficiency, these items should be added at the first of the loading process.
- D.** When adding minute supplements or medication in non-liquid form, these ingredients should be loaded in the middle of the loading sequence.
- E. RATIONS WITH GROUND HAY:**
 - 1. Load molasses (or liquids) first with the mixer not running.
 - 2. Load one (1) commodity ingredient and start mixer.
 - 3. Finish loading commodities, silage, or ground hay. Loading ground hay after mixing liquids with another commodity will prevent molasses hay balls.

NOTE: These procedures may not work on all rations. Loading sequences may be changed to give best possible mix.

ATTENTION:

- F.** Never load the mixer from the right side (side opposite the discharge) with a front end loader or payloader.

OPERATION:

Trailer mounted mixers can be furnished with single tractor controls or dual controls. Dual controls are standard unless specified.

1. Single controls operate as follows: Spout goes down first - door opens second. Door closes first - spout goes up second.
2. The disadvantage of the single control is that it does not let you adjust the spout height without first closing the door.

ROTO-HAY PROCESSOR

The ROTO-HAY PROCESSOR is designed for processing hay into the mixer. This eliminates the need for grinding hay, which saves the time and expense of grinding and can save up to 18% loss from wind and handling.

THE ROTO-HAY PROCESSOR MUST BE PROPERLY USED ALWAYS USE DRY HAY

Drain rain water out of mixer before use. 1" of rain in a 524-15 equals (72 gal) 586 lbs. of water which will increase the moisture in 1500 lbs. of dry hay (12%) to 37% moisture or 1000 lbs. of dry hay to 45% moisture.

The ROTO-HAY PROCESSOR will handle small amounts of damp hay, but this is done at your own risk. ROTO-MIX will not warranty bent or broken rotor tubes, bent or broken augers, or bent hay pans caused from misuse, wet hay, foreign objects, and/or overloading.

HAY PREPARATION:

1. **SMALL BALES** - (60 to 150 lbs., 2 or 3 wire) Remove twine or wire from bales and break bales apart by pushing into a pole with a front end loader.
2. **LARGE SQUARE BALES** - (3' x 4' x 8' or 4' x 4' x 8')
 - A. Position bale so you can get to end of bale with front end loader.
 - B. Remove twine or wrapping.
 - C. With front end loader, pull a 12" flake away from the bale so it can be picked up with loader bucket - or - by adding 3 or 4 teeth (12" long) to the top of your loader bucket, you can stab the end of the bale and pick up a 12" flake to lay on the mixer hay pan.
3. **ROUND BALES**
 - A. Remove twine or wrapping.
 - B. Cut bale with a ROTO-BALE CUTTER a minimum of 5 times to part the bale into a minimum of 12" chunks. More times may be desired for ease of handling.
 - C. Break bales apart by pushing into a pole with a front end loader so the hay can be loaded in quantities of approximately 200 lbs. at a time.

LOADING INSTRUCTIONS FOR HAY PROCESSOR

Load all commodities except liquids on the discharge (auger) side with the hay pan in the raised position. The raised hay pan does not affect the mixing action

1. If molasses and/or liquid protein is used, load on the rotor side of the mixer first with the mixer not running.
2. Load one (1) grain or dry commodity in a minimum amount equal to the amount of hay to be put into mixer with the mixer not running.
3. Start the mixer and run approximately one (1) minute before adding hay.
4. With the mixer running at a minimum rotor speed of 4 RPM, load prepared hay towards the front of the hay pan on discharge side of mixer. For best results, when loading with a tractor front end loader or payloader, each bucket load should not exceed 200 lbs at one time. Allow time for the hay to be processed into the mixer before loading another 200 lbs. Repeat until desired amount of hay is processed (DO NOT OVERLOAD). Let the mixer run until desired length of hay is reached.
5. Finish loading dry commodities.
6. Load wet feeds, such as silage, after all commodities and hay are in the mixer.
7. If water is to be added to the ration - **Do this last!**

MIXER INFORMATION

The mixer trailers are equipped with recapped tires with a new tread cap.

LUBRICATION CHART

DISENGAGE PTO & SHUT OFF POWER BEFORE LUBRICATING THE MACHINE.

LOOSE OR FLOPPY CLOTHING SHOULD NOT BE WORN BY THE OPERATOR.

OIL BATH: Fill the oil bath with 30 weight motor oil to sight plug level.

GREASE BANK: Grease every 100 hours.

FRONT END BEARINGS: Grease every 100 hours.

INPUT BEARINGS: One (1) on input shaft beneath mixer/feeder. Grease every 100 hours.

PTO SHAFTS & U-JOINTS: Grease every 10 to 20 hours.

GEARBOX: Prior to operation, remove the uppermost plug and replace with vent plug provided. After the first 100 hours of operation, drain the initial oil, preferably warm. Flush the gear case with an approved non-flammable, non-toxic solvent and refill with oil. Thereafter oil should be changed every 2500 hours or every 12 months, whichever occurs first. Fill the gearbox with 1-1/2 pints of (Mobil Delvac Synthetic Gear Oil 75W-90).



524-15 SPECIFICATIONS

Capacity (Cu. ft.)	520
Struck level capacity (Cu. ft.)	560
Top Auger Bearing (Front)	2-3/16" 4-Bolt
Top Auger Bearing (Rear).....	3" 4-Bolt
Bottom Auger Bearing (Front)	2-7/16" 4-Bolt
Bottom Auger Bearing (Rear)	3-1/2" 4-Bolt
Rotor Bearing (Front)	2-15/16" 4-Bolt
Rotor Bearing (Rear).....	4" 4-Bolt
Top Auger Sprockets	120 A 26H & 100 A 54
Bottom Auger Sprockets	120 A 48 & 120 B 13
Rotor Sprocket	120 A 100
Jackshaft Sprockets	100 B 17H & 80 B 48 - Trk & Trl 540 PTO 100 B 15H & 80 B 48 - 1000 PTO
Drive Sprockets.....	80 B 25H - Trk & Trl 540 PTO 80 B 15H - Trl 1000 PTO
Top Auger Flighting.....	3/8" x 20"OD RH 14" Pitch
Bottom Auger Flighting	1/2" x 20"OD RH & LH Full Pitch
Tub Bottom Construction	1/4" Steel
Auger Bottom Construction.....	1/4" Steel
Right Side Sheet Construction.....	7GA (3/16") Steel
Left Side Sheet Construction	7GA (3/16") Steel
Front End Sheet Construction.....	1/4" Steel
Rear End Sheet Construction	1/4" Steel

PTO CHART

524-15

	PTO (% ENGINE SPEED)	GEARBOX (RATIO)	INPUT SPROCKET	JACKSHAFT SPROCKET
DIESEL AUTO TRANS	80-85 250 FT./LB MIN. Engine Rotation	3:1	25 Tooth	17 Tooth 48 Tooth

FOR OTHER ENGINE OR TRANSMISSION APPLICATIONS CONSULT FACTORY

1000 TRACTOR DRIVE (OPTIONAL)			15 Tooth	15 Tooth 48 Tooth
--	--	--	----------	----------------------

540 TRACTOR DRIVE (STANDARD)			25 Tooth	17 Tooth 48 Tooth
---	--	--	----------	----------------------

STATIONARY	BELT RATIO 30 HP 5V-2 Groove 16" & 5V-3 Groove 9.25" 2 Belts 5V-1060 25HP 5V-2 Groove 16" & 5V-3 Groove 9.25" 2 Belts 5V-1060
-------------------	--

NOTE: IF OPTIONAL HAY PROCESSOR IS INSTALLED A 30HP MOTOR IS REQUIRED.

524-15 TRUCK DIMENSIONS

HEIGHT DIMENSIONS BASED ON 38" TRUCK
FRAME WITH 20" SPOUT STANDARD

APPROXIMATE WEIGHT
 524-15 ON TRUCK 10,800 LB.
 WITH HAY PROCESSOR 11,550 LB.

	17" SPOUT	20" SPOUT
A	45-1/2"	43-1/2"
B	42-1/2"	40-1/2"
C	18"	20-1/2"
D	22"	24-1/2"

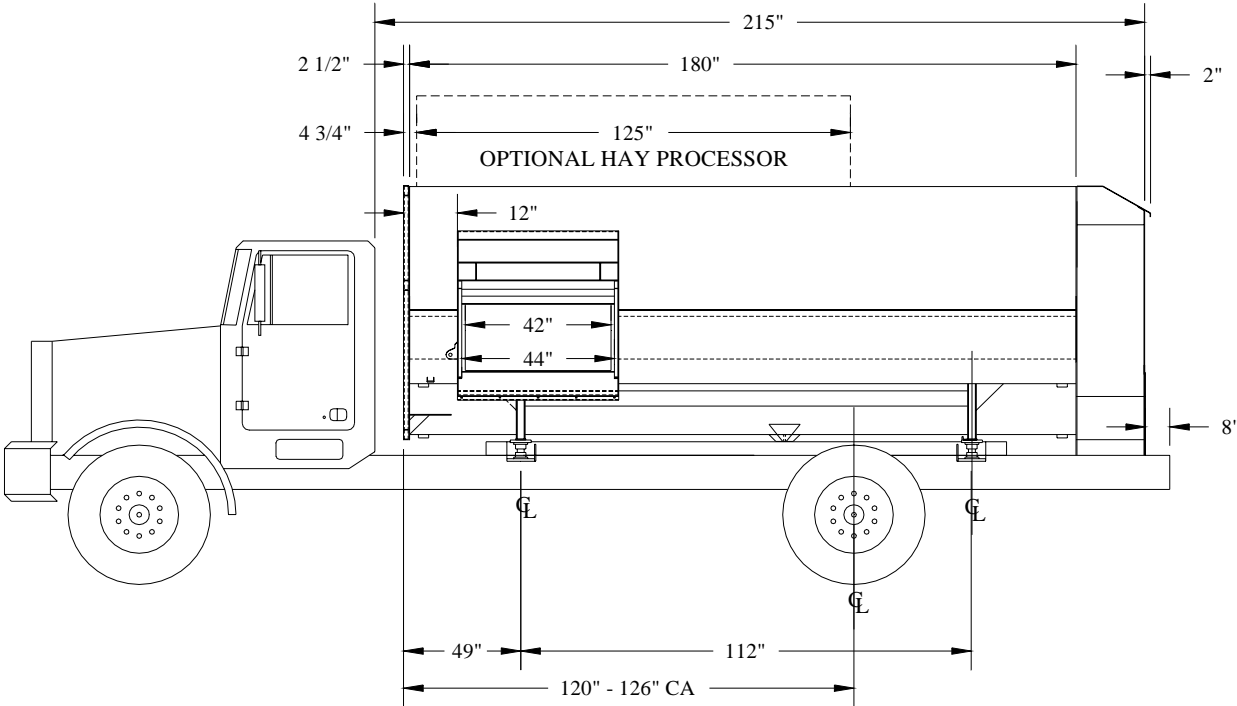
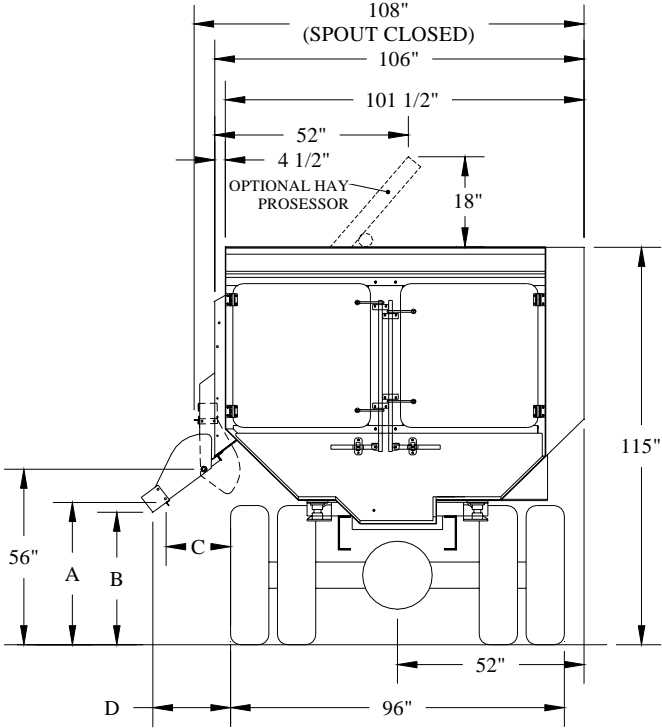

All Dimensions & Specifications are Approximate and Subject to Change Without Notice

524-15 TRAILER DIMENSIONS

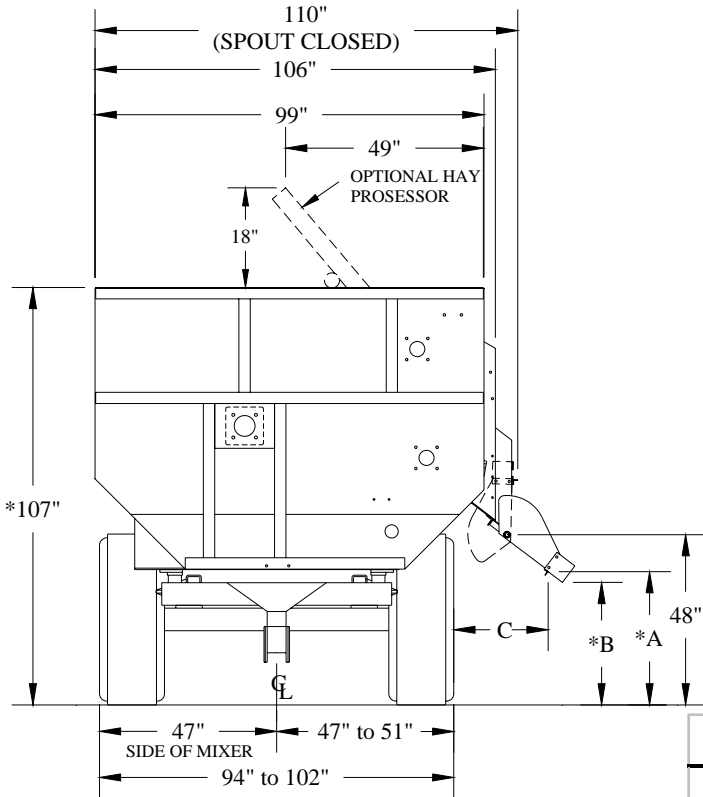

**HEIGHT DIMENSIONS ARE
BASED ON 44" O.D. TIRES
17" SPOUT STANDARD**

APPROXIMATE WEIGHT
524-15 ON TRAILER 12,500 lbs
W/HAY PROCESSOR..... 13,250 lbs

*INCREASE DIMENSIONS BY 4"
WHEN OPTIONAL RISER
BLOCKS ARE INSTALLED.

	17" SPOUT	20" SPOUT
A	37-1/2"	35-1/2"
B	34-1/2"	32-1/2"
C	16" - 20"	18-1/2" - 22-1/2"
D	20" - 24"	22-1/2" - 26-1/2"

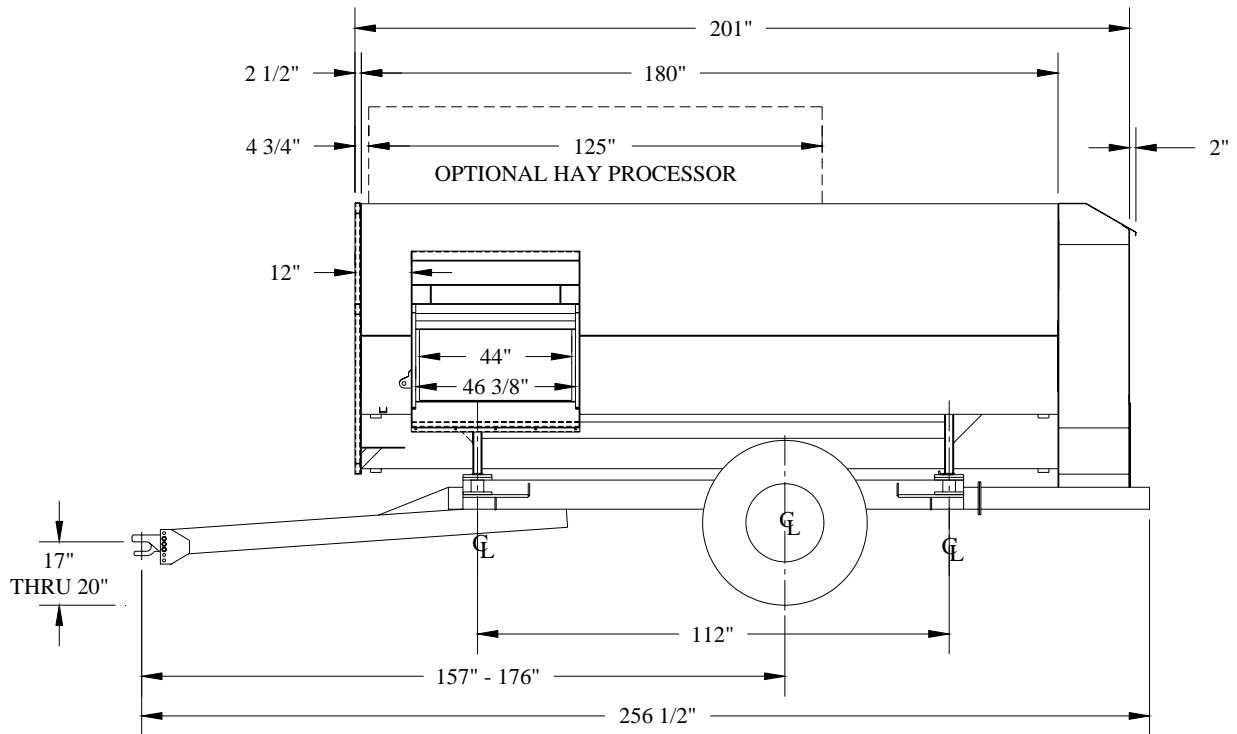

All Dimensions & Specifications are Approximate and Subject to Change Without Notice

524-15 TRAILER DIMENSIONS (WITH CONVEYOR)

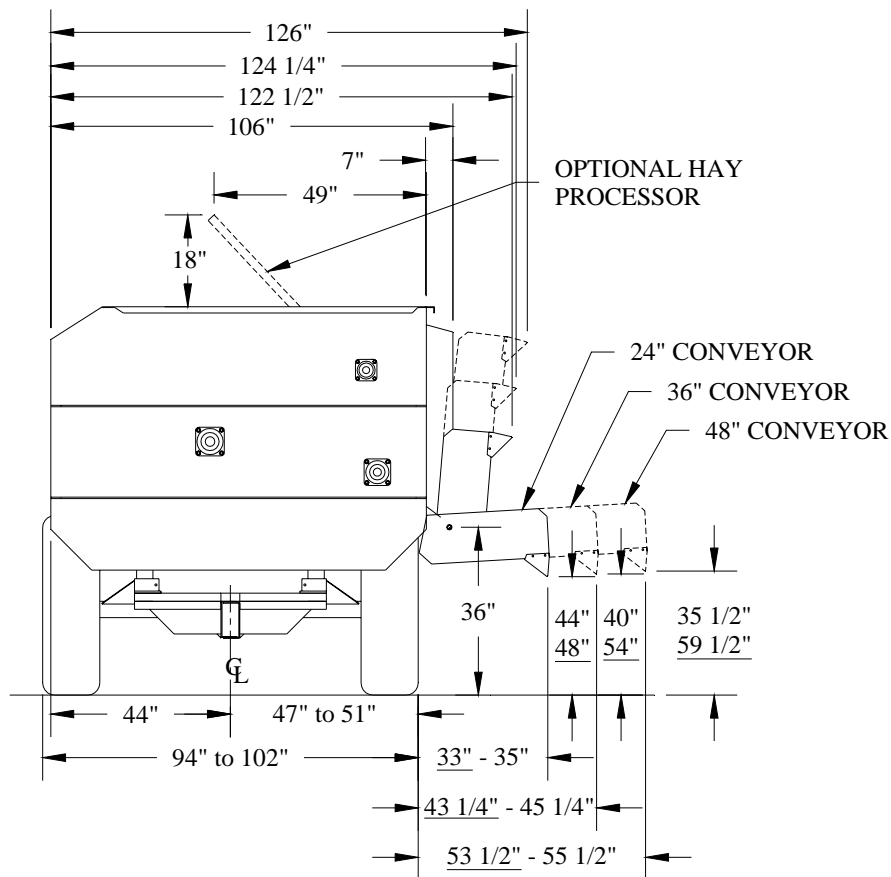

**NOTE: UNDERLINED DIMENSIONS ARE WITH
CONVEYOR SET AT ITS MAXIMUM
OPERATING ANGLE OF 30 DEGREES**

All Dimensions & Specifications are Approximate and Subject to Change Without Notice

524-15 STATIONARY DIMENSIONS

APPROXIMATE WEIGHT, LESS MOTOR
 524-15 STATIONARY..... 10,500 LB.
 WITH HAY PROCESSOR..... 11,250 LB.

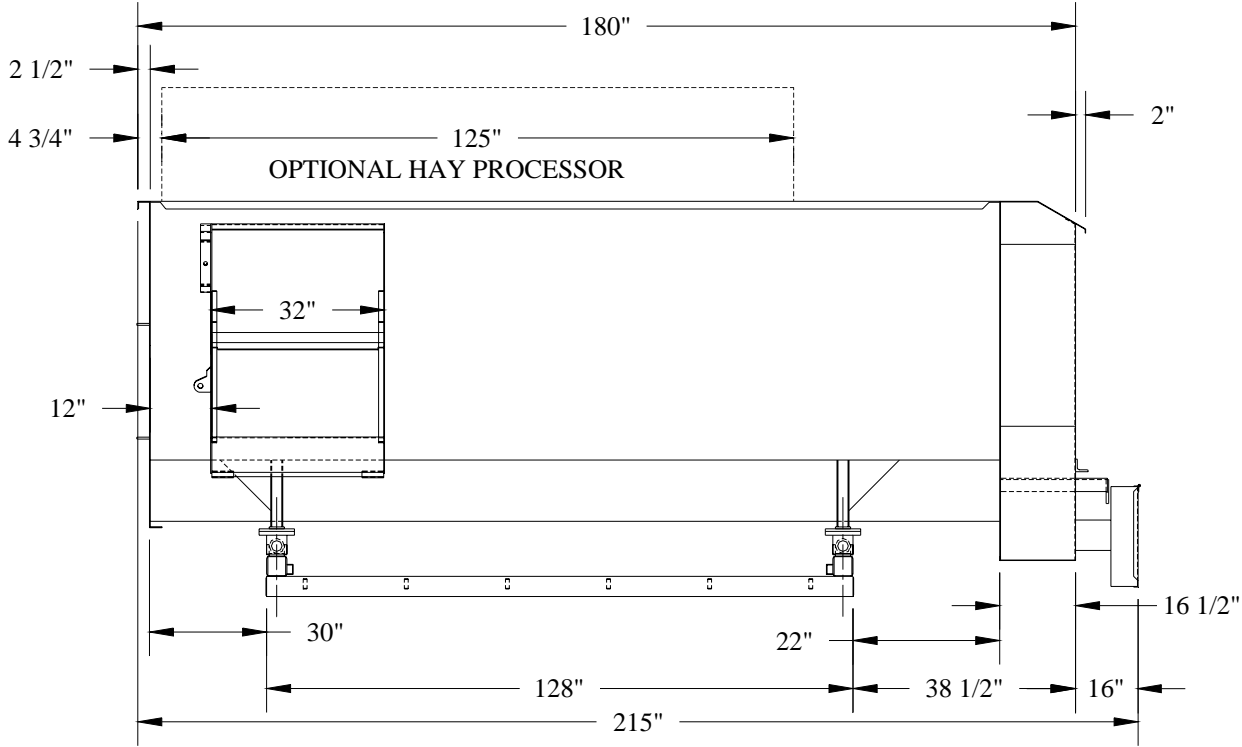
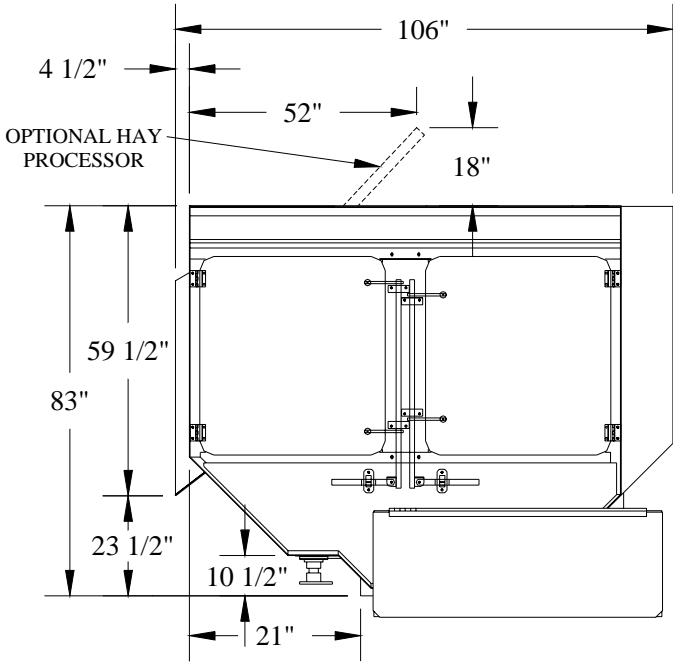

All Dimensions & Specifications are Approximate and Subject to Change Without Notice

524-15 MOUNTING DIMENSIONS

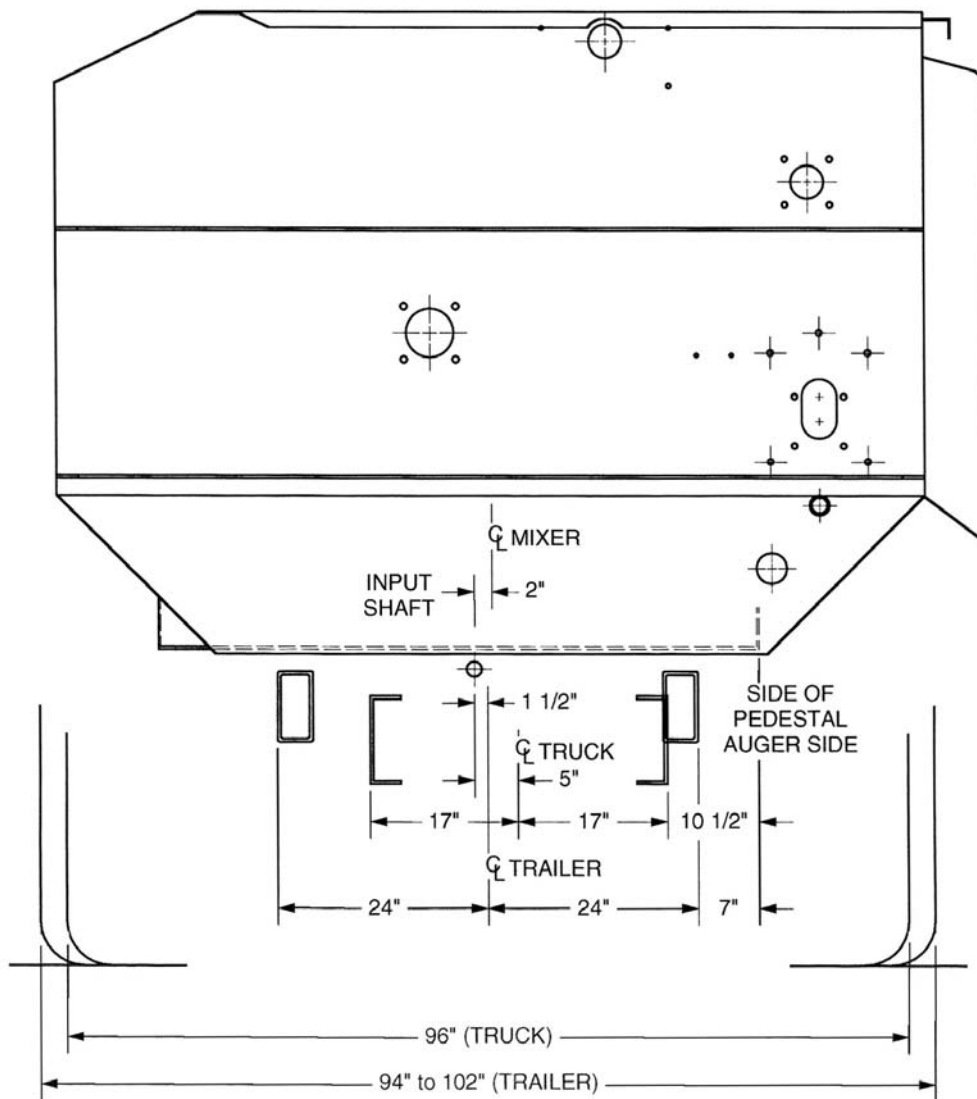

All Dimensions & Specifications are Approximate and Subject to Change Without Notice

524-15 MOUNTING DIMENSIONS

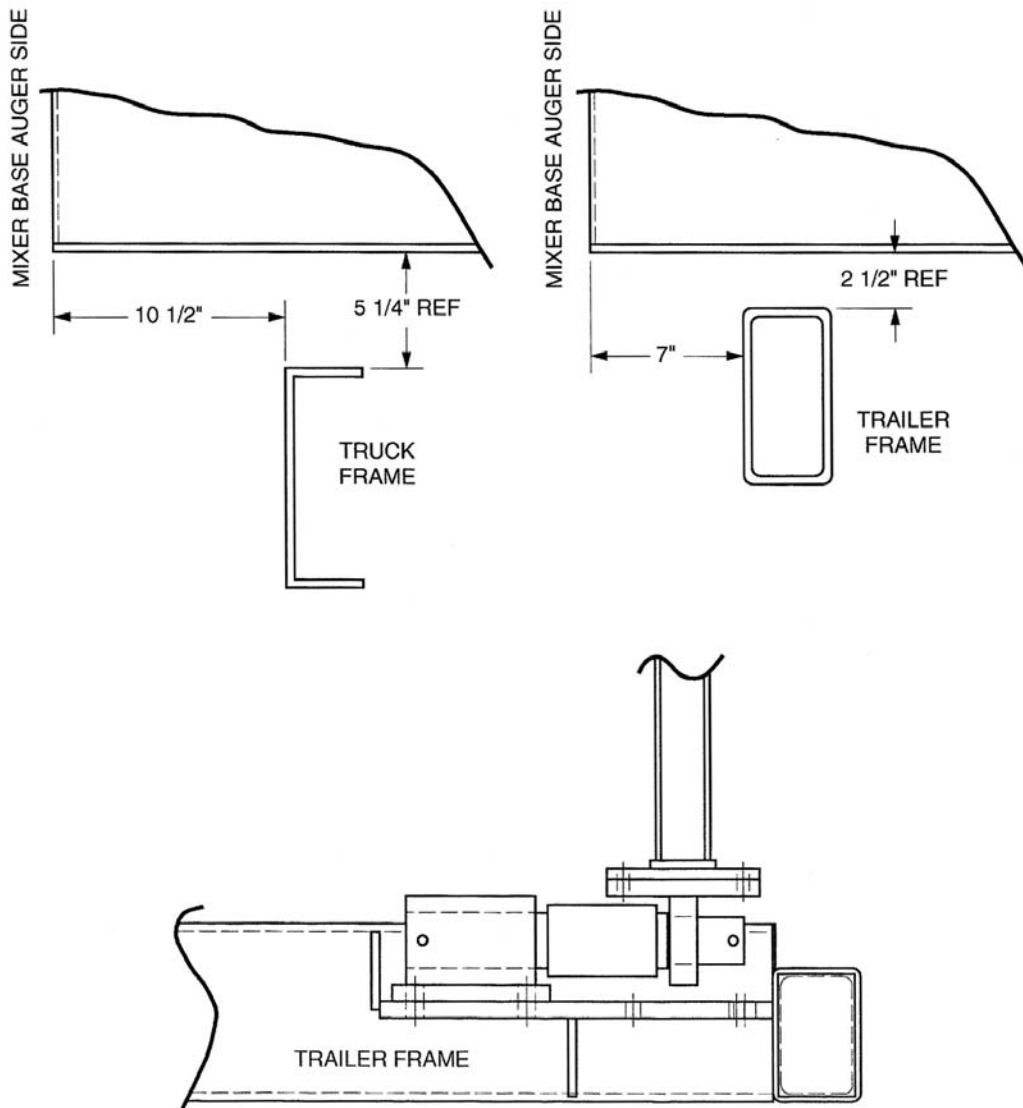

All Dimensions & Specifications are Approximate and Subject to Change Without Notice

PARTS PAGES

TABLE OF CONTENTS

	PAGE NO.
WIRING SCHEMATIC FOR STRAIGHT DOOR	34
JOYSTICK ASSEMBLY	35
MV5 DOUBLE HYDRAULIC VALVE ASSEMBLY	36
12V DOUBLE HYDRAULIC VALVE ASSEMBLY	37
HYDRAULIC PUMP, TRUCK	38
OIL RESERVOIR ASSEMBLY	39
HYDRAULIC SCHEMATIC FOR STRAIGHT DOOR.....	40
STATIONARY HYDRAULIC ASSEMBLY	41
DISCHARGE DOOR ASSEMBLY	42
DISCHARGE DOOR HAND WHEEL ASSEMBLY	43
17" SPOUT ASSEMBLY	44
20" SPOUT ASSEMBLY	45
SPOUT MAGNET ASSEMBLY	46
SPOUT RUBBER.....	47
CHAIN CONVEYOR ASSEMBLY	48-49
CHAIN CONVEYOR HYDRAULIC ASSEMBLY	50
CONVEYOR HYDRAULIC ASSEMBLY (2 CYLINDER).....	51
SCALE INDICATOR ASSEMBLY	52
OIL BATH DOOR ASSEMBLY	53
LUBRICATION ASSEMBLY (OIL BATH).....	54
STAGGERED ROTOR ASSEMBLY	55
3 ARM ROTOR ASSEMBLY	56
5 ARM ROTOR ASSEMBLY	57
TOP & BOTTOM AUGER ASSEMBLY.....	58
FRONT END BEARING ASSEMBLY	59
DRIVE ASSEMBLY.....	60-63
STATIONARY DRIVE ASSEMBLY	64-65
DRIVE LINE GEARBOX ASSEMBLY	66
TRUCK DRIVELINE ASSEMBLY	67
TRUCK DRIVESHAFT ASSEMBLY.....	68
TRAILER DRIVELINE ASSEMBLY.....	69
TRAILER DRIVESHAFT ASSEMBLY	70
TRAILER LOADCELL SCALE ASSEMBLY.....	71
TRAILER WEIGH BAR ASSEMBLY	72
TRUCK LOADCELL SCALE FRAME ASSEMBLY.....	73
TRUCK WEIGH BAR SCALE FRAME ASSEMBLY	74
STATIONARY LOAD CELL SCALE FRAME ASSEMBLY	75
TRAILER ASSEMBLY	76
HUB & SPINDLE ASSEMBLY	77
ROTO-HAY PROCESSOR ASSEMBLY (HYDRAULIC OPTION).....	78
ROTO-HAY PROCESSOR ASSEMBLY	79
ROTO-HAY PROCESSOR ASSEMBLY (CABLE OPTION).....	80
BOTTOM AUGER FLOAT ASSEMBLY	81
FENDERS & MUD FLAPS	82

WIRING SCHEMATIC FOR STRAIGHT DOOR

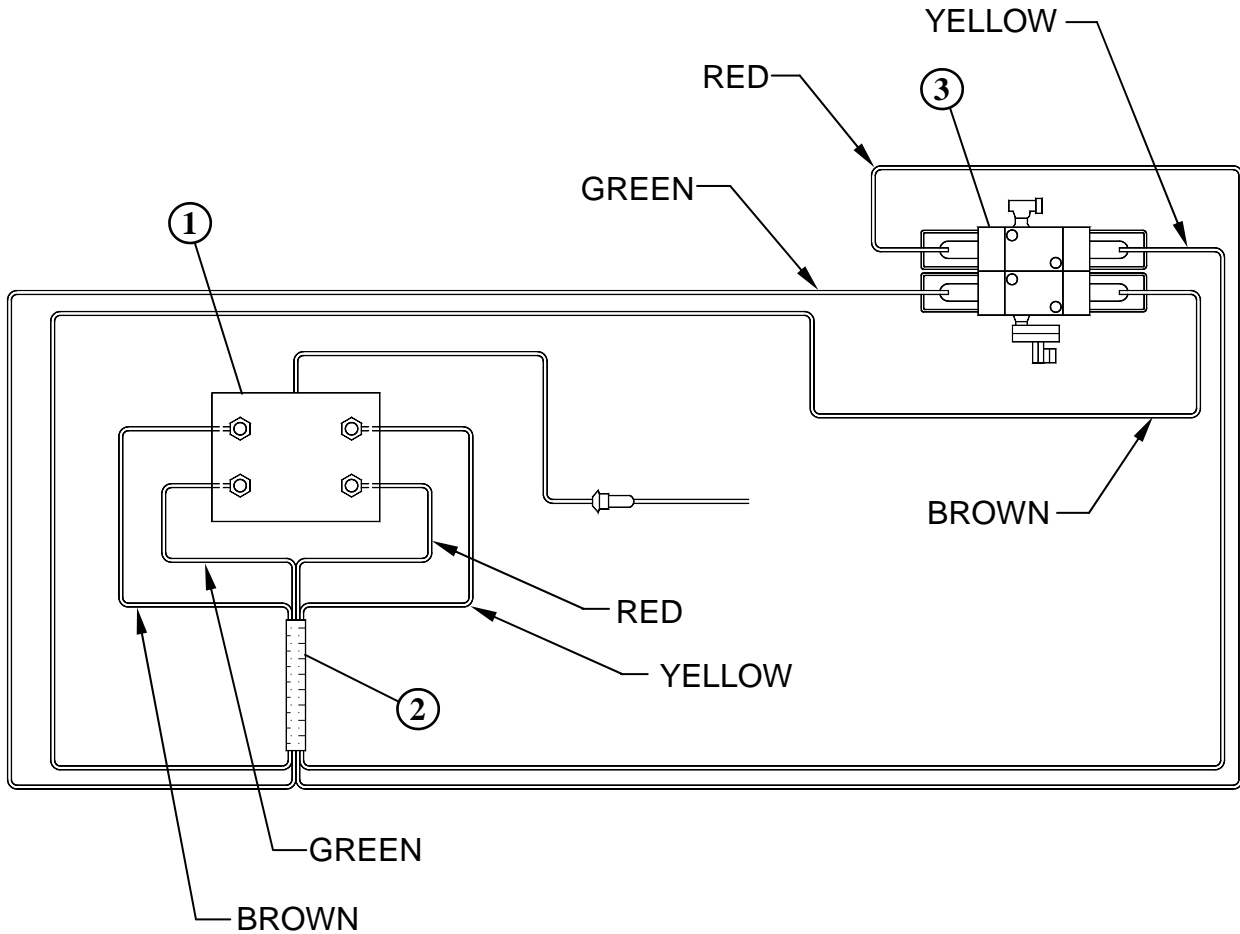

REF. NO	PART NO.	DESCRIPTION	QTY.
1			
A	780080	PUSH BUTTON SWITCH PANEL	
B	780081	JOYSTICK PANEL	1
2	781055	TRUCK TO MIXER WIRE ASSEMBLY	1
3	780123	HYDRAULIC CONTROL VALVE.....	1

JOYSTICK ASSEMBLY

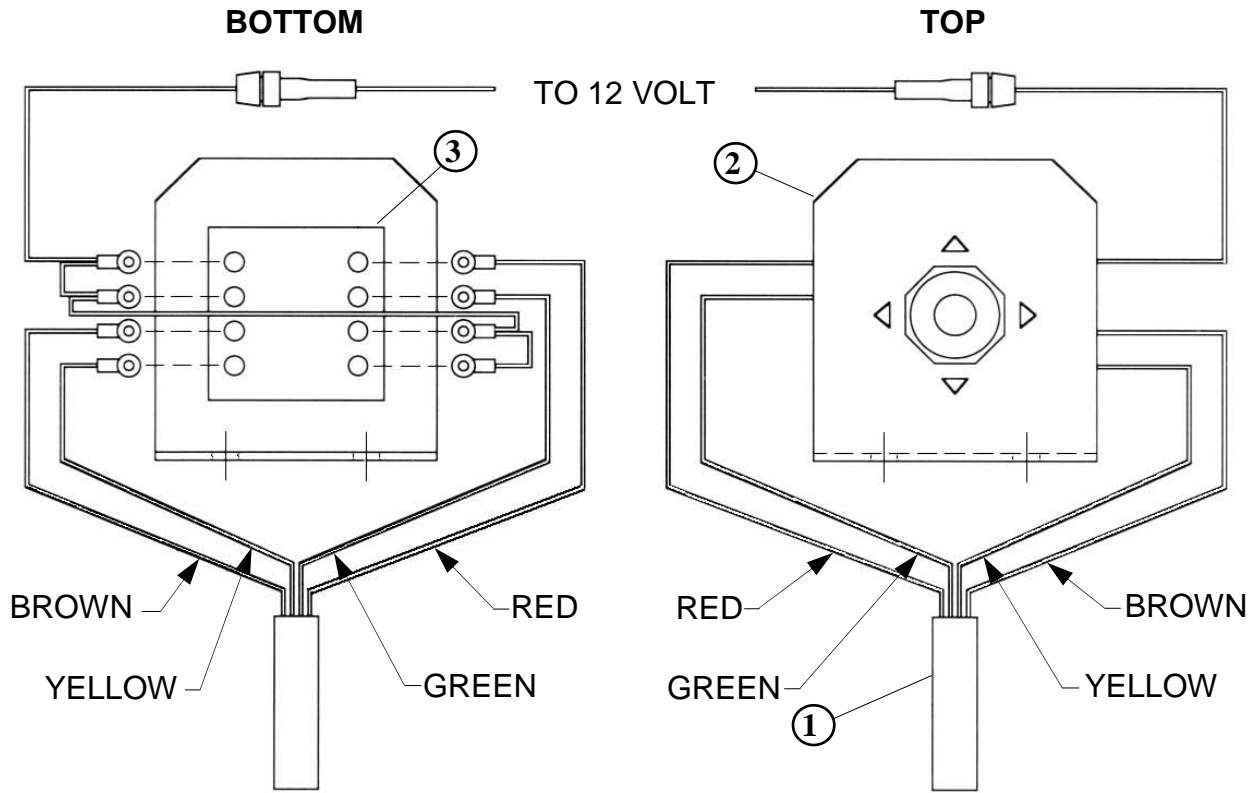

REF. NO	PART NO.	DESCRIPTION	QTY.
1	781056	SWITCH WIRE ASSEMBLY	1
2	185575	JOYSTICK BRACKET	1
3	357705	JOYSTICK SWITCH.....	1

MV5 DOUBLE HYDRAULIC ASSEMBLY (780123 OLD STYLE)

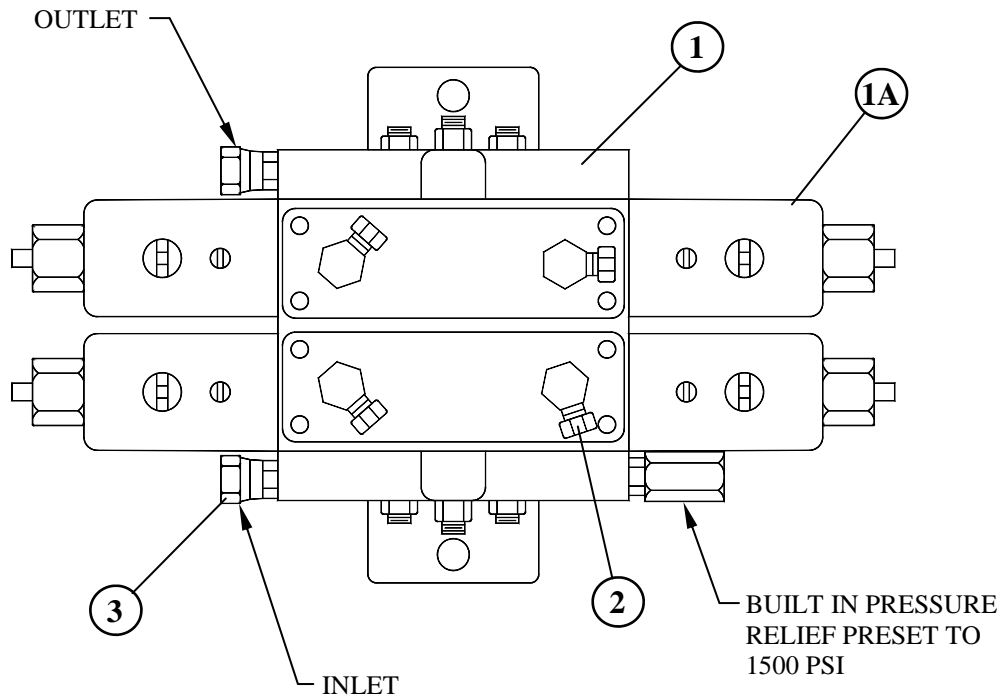

REF. NO	PART NO.	DESCRIPTION	QTY.
1	362209	HYDRAULIC VALVE 12V DOUBLE	1
1A	362206	12V SING MV5 HYD VLV MVSR 1500-10-50-12-TD.....	2
2	368030	FITTING, 9/16" MOR x 3/8" FPSW 90°	4
3	368115	FITTING, 9/16" MOR x 3/8" FPSW STRT	2

12V DOUBLE HYDRAULIC ASSEMBLY (780123 NEW STYLE)

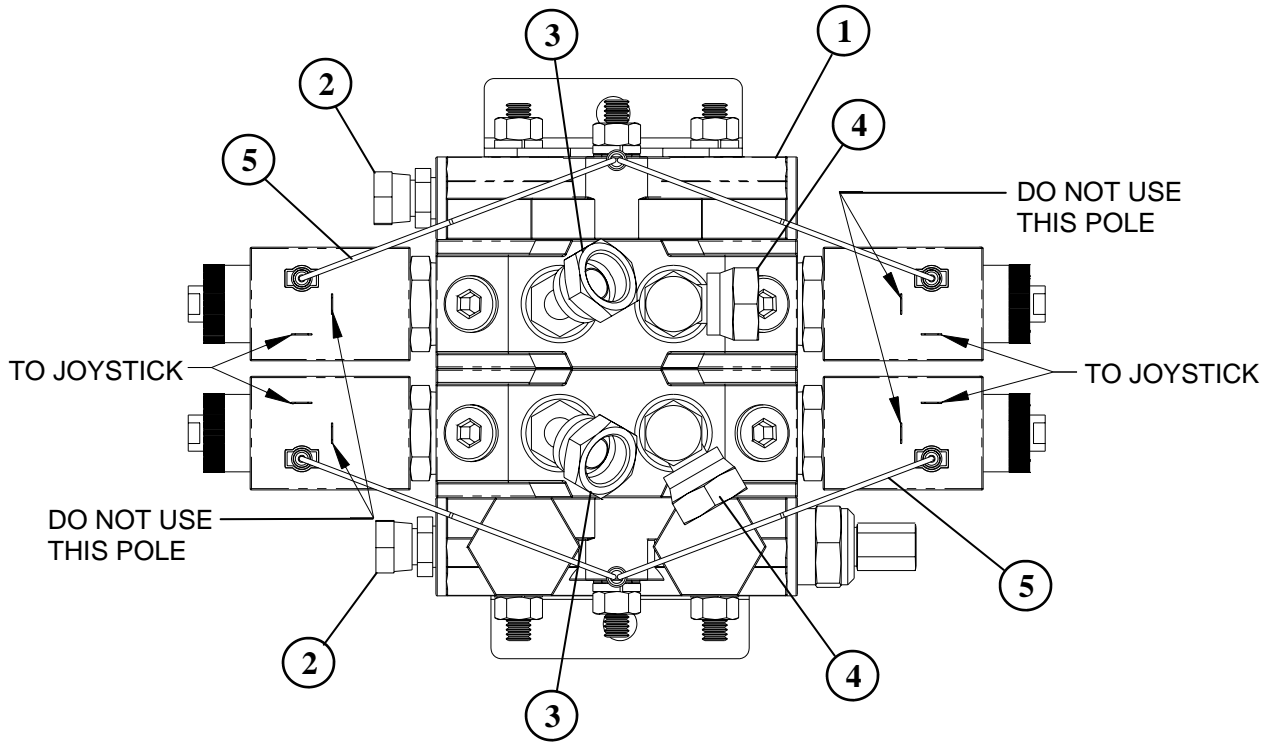

REF. NO	PART NO.	DESCRIPTION	QTY.
1	362209	HYDRAULIC VALVE 12V DOUBLE.....	1
2	368115	FITTING, 9/16" MOR x 3/8" FPS.....	2
3	368024	FITTING, 45° SWIVEL 9/16" MOR x 3/8" FPS.....	2
4	368030	FITTING, 90° SWIVEL 9/16" MOR x 3/8" FPS.....	2
5	781057	SOLENOID GROUND WIRE, 12 VOLT	2

HYDRAULIC PUMP, TRUCK (780064)

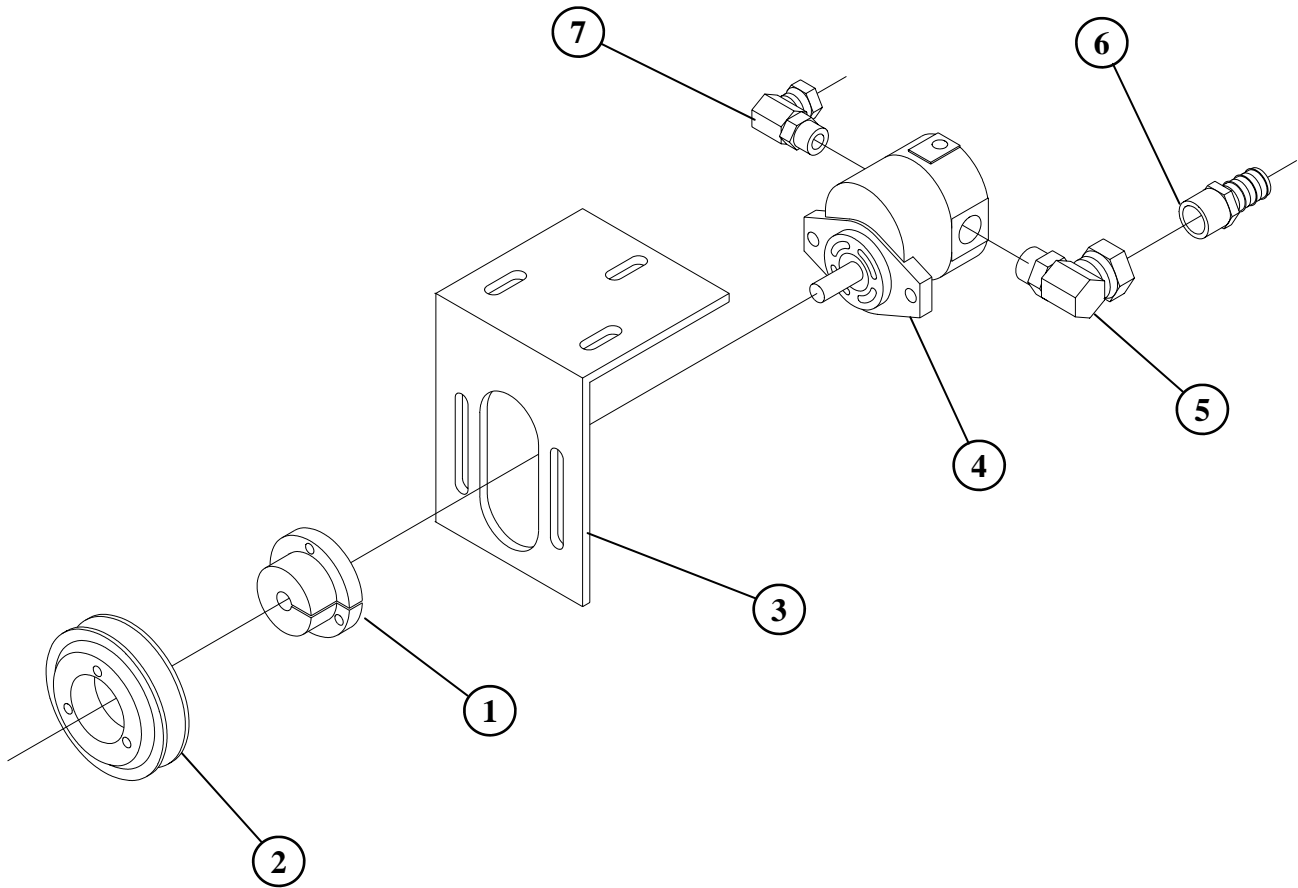

REF. NO	PART NO.	DESCRIPTION	QTY.
1	336008	BUSHING, SH1/2" QD.....	1
2	324040	SHEAVE, 1B 4.0" V-BELT.....	1
3	189053	HYDRAULIC PUMP BRACKET.....	1
4	362017	HYDRAULIC PUMP (D17AA2A).....	1
5	368050	FITTING, 7/8" MOR x 3/4" FPSW 90°.....	1
6	368512	FITTING, 3/4" MP x 3/4" PUSH LOCK BARB.....	1
7	368040	FITTING, 3/4" MOR x 3/8" FPSW 90°.....	1

OIL RESERVOIR ASSEMBLY (780205)

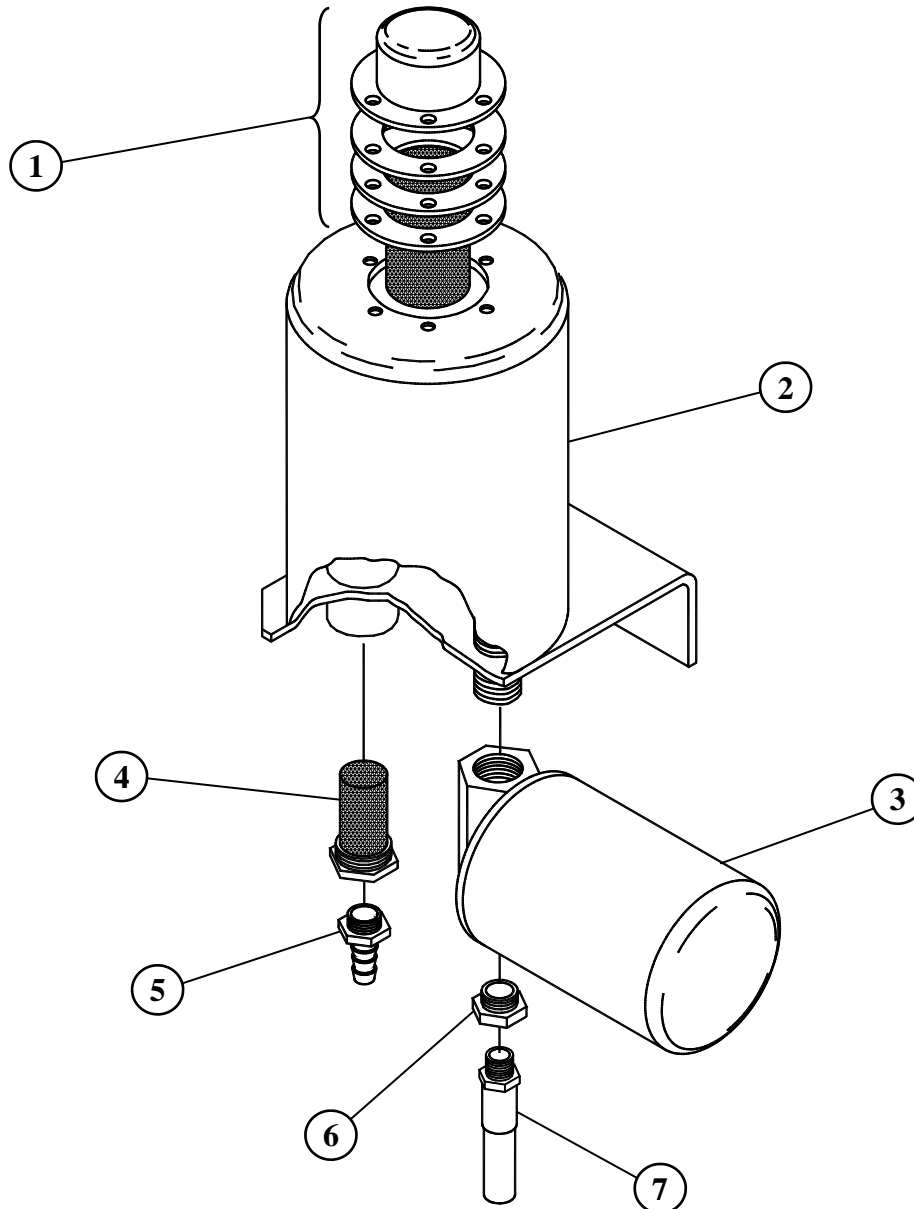

REF. NO	PART NO.	DESCRIPTION	QTY.
1	362550	FILLER CAP.....	1
2	870477	OIL RESERVOIR WELDMENT.....	1
3	352400	OIL FILTER ASSEMBLY.....	1
A	362403	FILTER HEAD	
B	352440	FILTER ELEMENT	
4	362504	SUCTION SCREEN.....	1
5	368512	FITTING, 3/4" MP x 3/4" PUSH LOCK BARB.....	1
6	368665	FITTING, 3/4" x 3/8" REDUCER.....	1
7	781059	HYD HOSE ASSEMBLY, 3/8" x 20" x 3/8" ENDS.....	1

HYDRAULIC SCHEMATIC FOR STRAIGHT DOOR

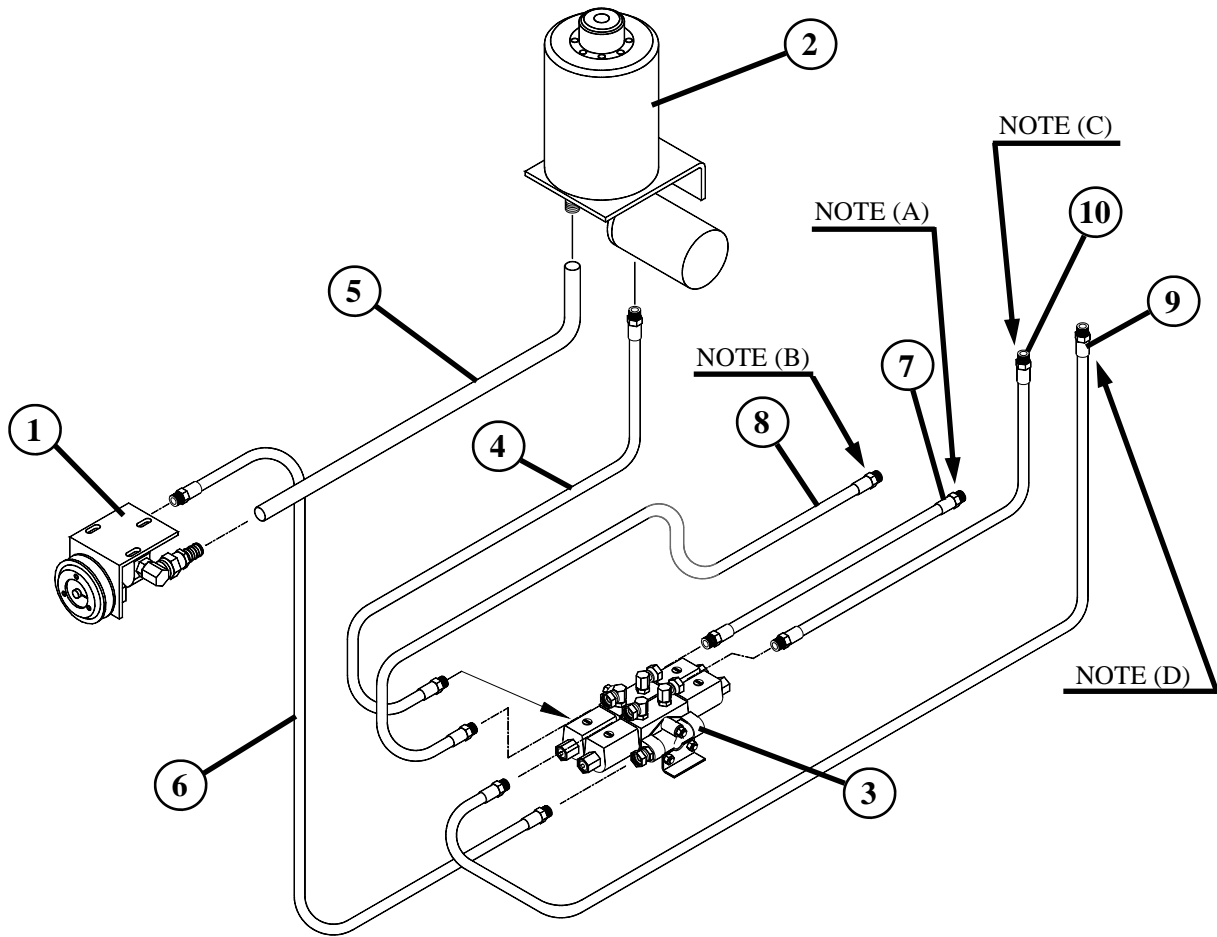

NOTE A: CONNECT TO SPOUT CYLINDER BASE

NOTE B: CONNECT TO SPOUT CYLINDER ROD END

NOTE C: CONNECT TO DOOR CYLINDER BASE

NOTE D: CONNECT TO DOOR CYLINDER ROD END

REF. NO	PART NO.	DESCRIPTION	QTY.
1	780064	HYDRAULIC PUMP ASSEMBLY	1
2	780205	RESERVOIR ASSEMBLY	1
3	780123	HYDRAULIC VALVE ASSEMBLY	1
4	781059	HYD. HOSE ASSY. 3/8" x 20" w/3/8" MP ENDS	1
5	184291	HYD. HOSE ASSY. 3/4" x 144" (SUCTION LINE).....	1
6	781073	HYD. HOSE ASSY. 3/8" x 144" w/3/8" MP ENDS	1
7	781066	HYD. HOSE ASSY. w/3/8" MP & 1/4" MP ENDS	1
8	781069	HYD. HOSE ASSY. w/3/8" MP & 1/4" MP ENDS	1
9	781061	HYD. HOSE ASSY. w/3/8" MP ENDS	1
10	781098	HYD. HOSE ASSY. w/3/8" MP ENDS	1

STATIONARY HYDRAULIC ASSEMBLY

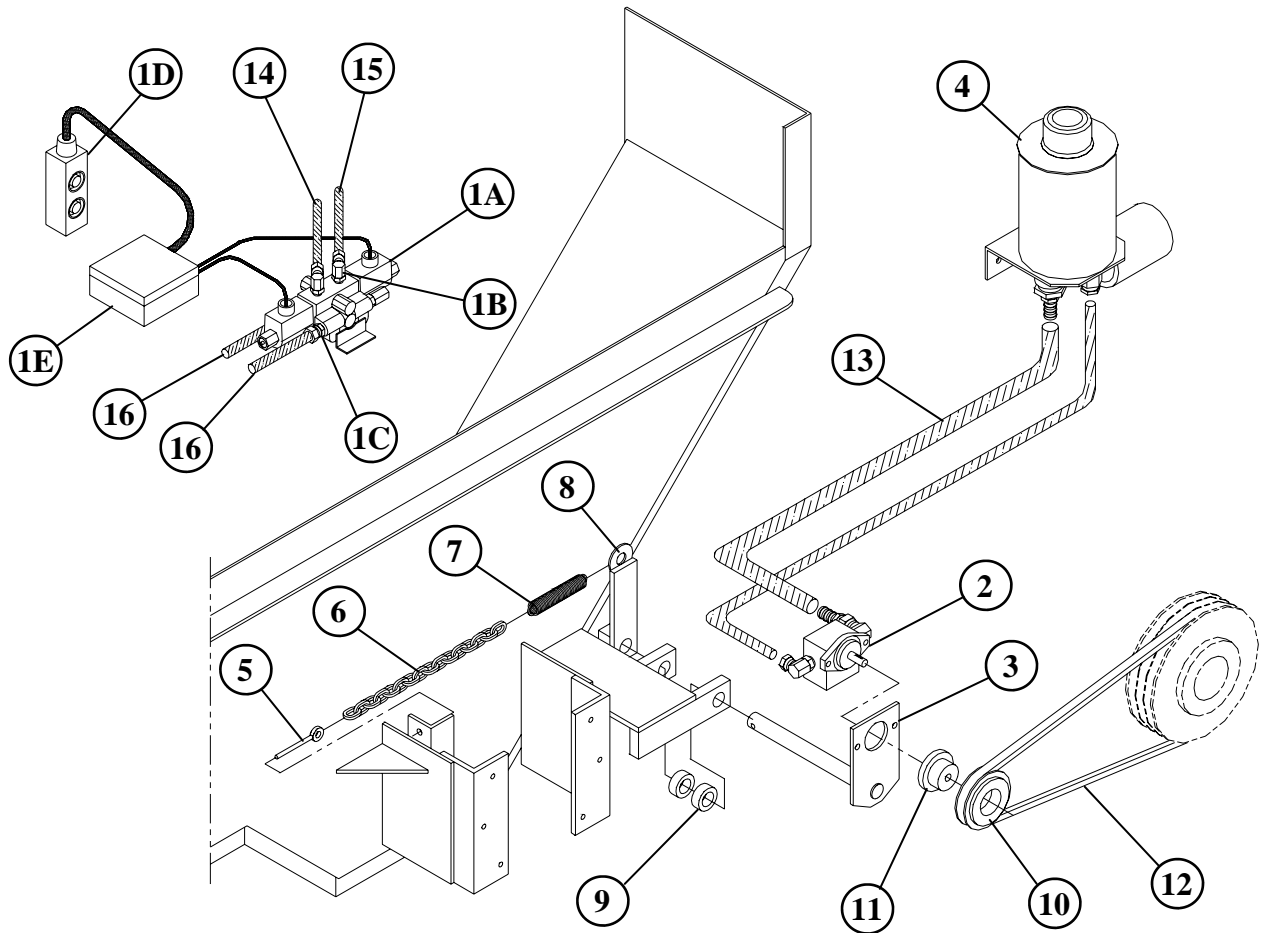

REF. NO	PART NO.	DESCRIPTION	QTY.
1	781004	HYDRAULIC VALVE ASSEMBLY.....	1
A	352205	SINGLE HYDRAULIC VALVE, 120V	1
B	368030	FITTING, 9/16" MOR x 3/8" FPSW 90°	2
C	368115	FITTING, 9/16" MOR x 3/8" FPSW STRT	2
D	357700	PENDANT SWITCH WH-4052.....	1
E	453717	WEATHER PROOF BOX	1
2	781113	STATIONARY HYDRAULIC PUMP ASSEMBLY	1
3	872138	PUMP SWING ARM WELDMENT	1
4	781005	OIL RESERVOIR ASSEMBLY	1
5	410852	EYEBOLT, 3/8" X 8"	1
6	185488	2/0 PASSING LINK CHAIN x 18"	1
7	410008	PULL SPRING, 1-1/4" x 5-1/4"	1
8	872136	PUMP LEVER ARM WELDMENT.....	1
9	412416	1" SET COLLAR.....	2
10	324040	BELT SHEAVE, 1B x 4.0" SH	1
11	336008	BUSHING, SH 1/2" QD	1
12	325060	V-BELT, B60	1
13	189088	SUCTION HOSE, 3/4" x 94"	1
14	781075	HYD HOSE ASSEMBLY, 3/8" x 180" x 3/8" MP ENDS.....	1
15	781077	HYD HOSE ASSEMBLY, 3/8" x 192" x 3/8" MP ENDS.....	1
16	781099	HYD HOSE ASSEMBLY, 3/8" x 120" x 3/8" MP ENDS.....	2

524-15 DISCHARGE DOOR ASSEMBLY

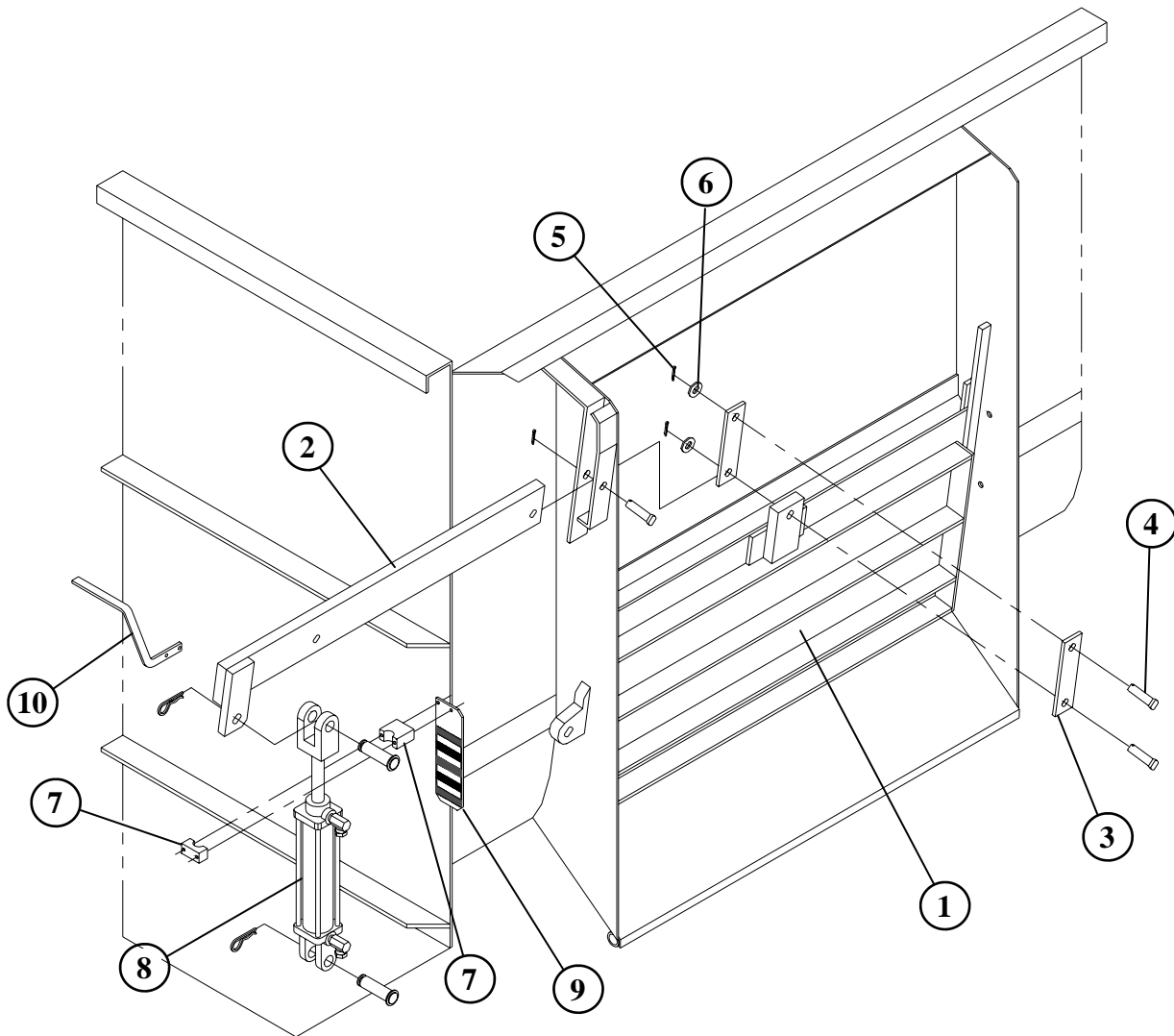

REF. NO	PART NO.	DESCRIPTION	QTY.
1	850140	DISCHARGE DOOR WELDMENT	1
2	850138	DOOR LEVER ARM WELDMENT	1
3	150049	DOOR ARM.....	2
4	404351	CLEVIS PIN 3/4" X 2-1/2".....	3
5	404003	COTTER PIN 5/32" X 1 1/4"	3
6	402512	FLAT WASHER 3/4" SAE.....	3
7	184267	DOOR CYLINDER MARKER CLAMP	1
8	780109	HYDRAULIC CYLINDER 2" X 8" (WITH FITTINGS)	1
A	364055	HYDRAULIC CYLINDER 2" X 8" (CYLINDER ONLY)	1
B	364954	HYDRAULIC CYLINDER ROD 2" X 8" X 1 1/16"	1
C	364400	HYDRAULIC CYLINDER 2" REPAIR KIT	1
9	184259	DOOR CYLINDER MARKER PLATE (TRUCK)	1
10	150385	DOOR MARKER BAR (TRAILER)	1

524-15 HAND WHEEL ASSEMBLY

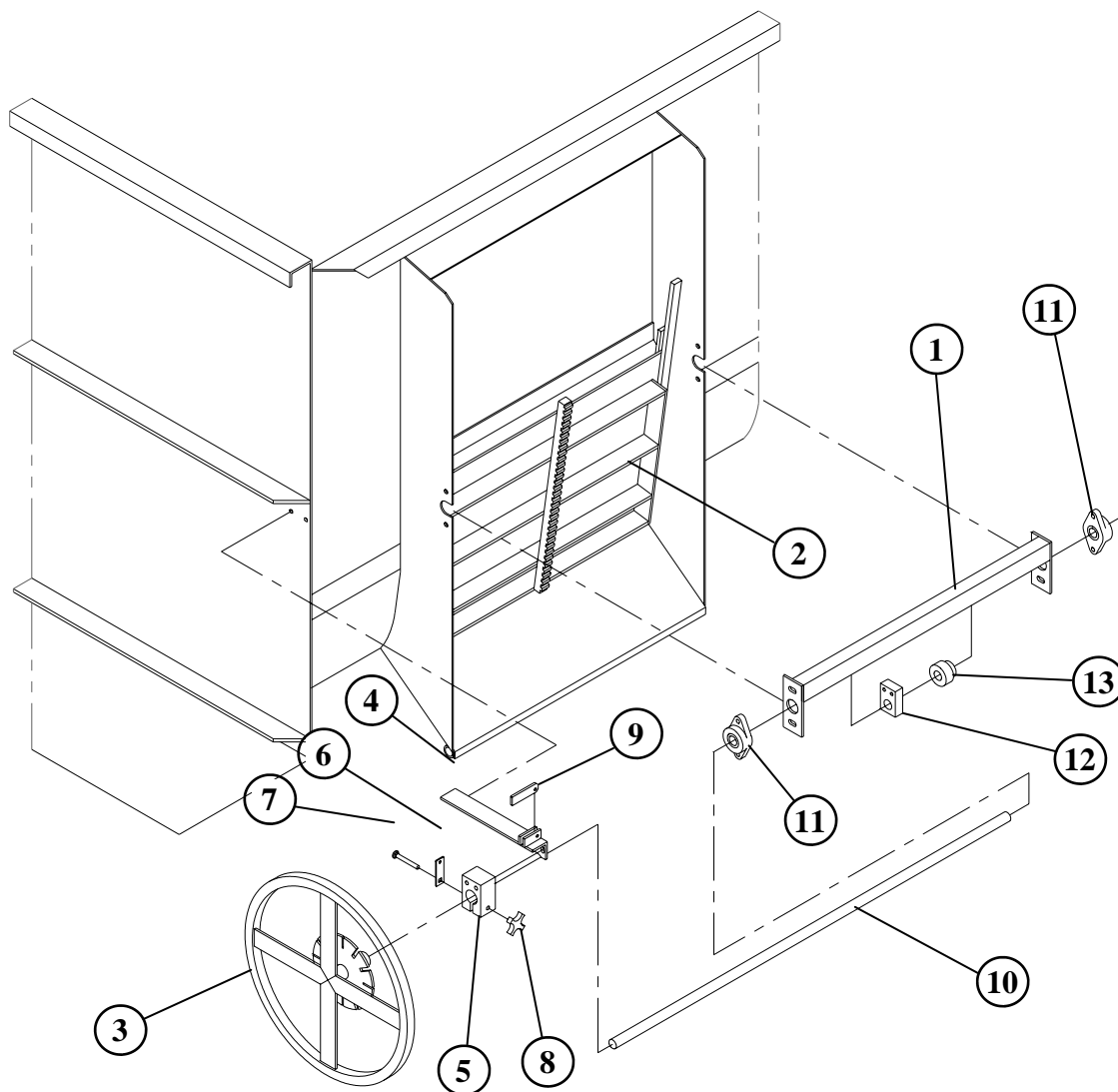

REF. NO	PART NO.	DESCRIPTION	QTY.
1	850079	HAND WHEEL FRAME WELDMENT	1
2	850145	524 STATIONARY DOOR WELDMENT	1
3	872030	HAND WHEEL WELDMENT.....	1
4	872349	BEARING BRAKE MOUNT WELDMENT	1
5	189105	BEARING BRAKE BLOCK UHMW	1
6	189106	HAND KNOB BOLT SUPPORT	1
7	407047	CARRIAGE BOLT 3/8"-16 X 3"	1
8	410305	HAND KNOB	1
9	189112	BRAKE ARM	1
10	150387	HAND WHEEL SHAFT.....	1
11	340216	FLANGE BEARING VCJT 1" 2-BOLT	2
12	150244	HAND WHEEL BEARING BLOCK UHMW.....	1
13	185114	GEAR S1020 X 1" BORE.....	1

17" SPOUT ASSEMBLY

#75004417" SPOUT ASSY WITH MAGNET

#75004517" SPOUT ASSY NO MAGNET

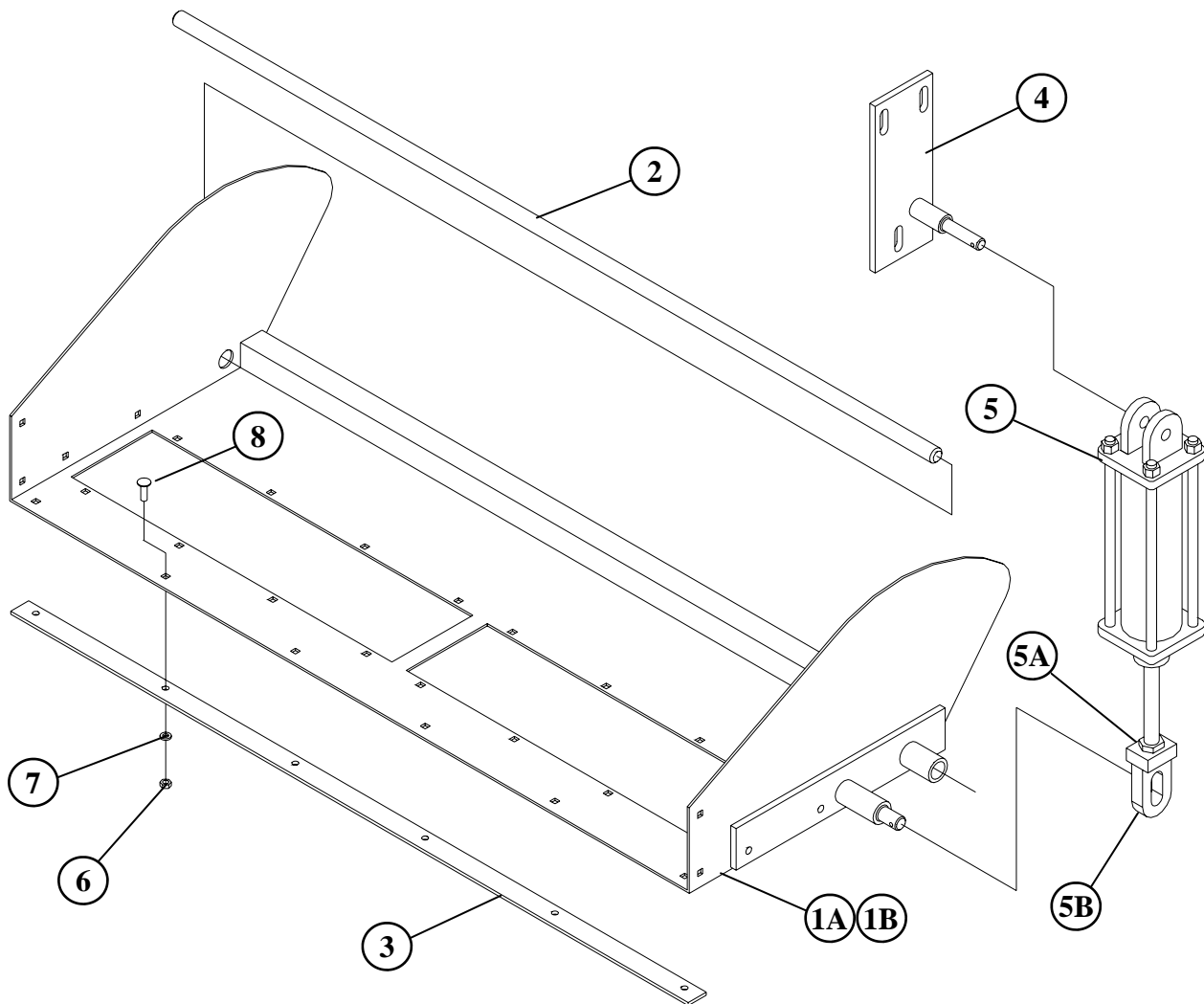

REF. NO	PART NO.	DESCRIPTION	QTY.
1A	850106	17" SPOUT WELDMENT WITH MAGNET	1
1B	850107	17" SPOUT WELDMENT NO MAGNET	1
2	150383	SPOUT PIVOT TUBE	1
3	183152	SPOUT BACK-UP ANGLE	1
4	850050	SPOUT CYLINDER TOP BRACKET WELDMENT	1
5	750019	SPOUT CYLINDER ASSEMBLY 1-1/2" x 8"	1
5A	400712	HEX JAM NUT 3/4"-16	1
5B	850053	SPOUT CYLINDER LUG.....	1
6	400205	HEX NUT 5/16"-18.....	10
7	402005	SPLIT LOCKWASHER 5/16"	10
8	407021	CARRIAGE BOLT 5/16"-18 x 1"	10

20" SPOUT ASSEMBLY

#75005420" SPOUT ASSY WITH MAGNET

#75005520" SPOUT ASSY NO MAGNET

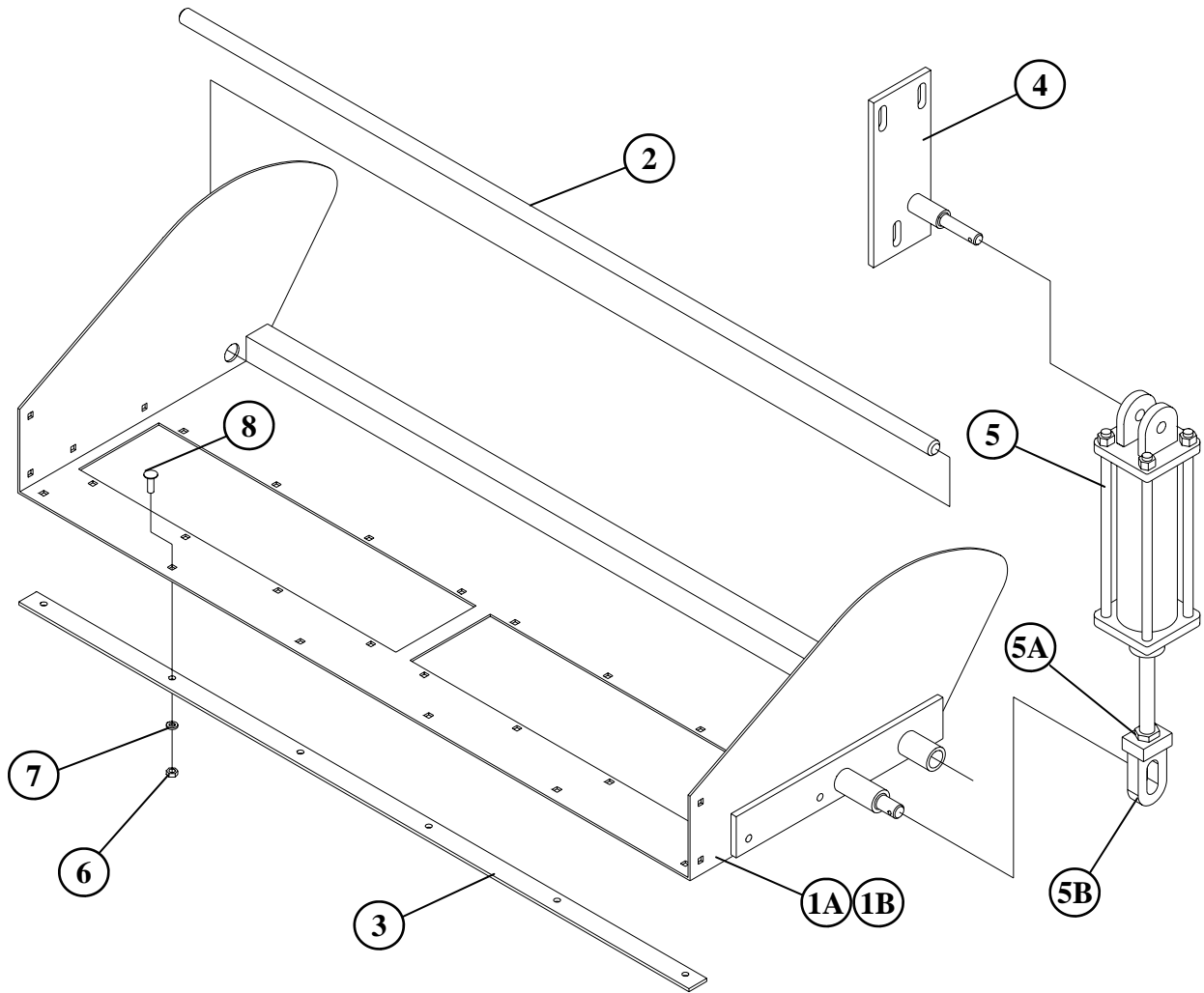

REF. NO	PART NO.	DESCRIPTION	QTY.
1A	850093	20" SPOUT WELDMENT WITH MAGNET.....	1
1B	850094	20" SPOUT WELDMENT NO MAGNET	1
2	150383	SPOUT PIVOT TUBE.....	1
3	183152	SPOUT BACK-UP ANGLE	1
4	850050	SPOUT CYLINDER TOP BRACKET WELDMENT	1
5	750019	SPOUT CYLINDER ASSEMBLY 1-1/2" x 8"	1
5A	400712	HEX JAM NUT 3/4"-16	1
5B	850053	SPOUT CYLINDER LUG	1
6	400205	HEX NUT 5/16"-18	10
7	402005	SPLIT LOCKWASHER 5/16"	10
8	407021	CARRIAGE BOLT 5/16"-18 x 1"	10

SPOUT MAGNET ASSEMBLY

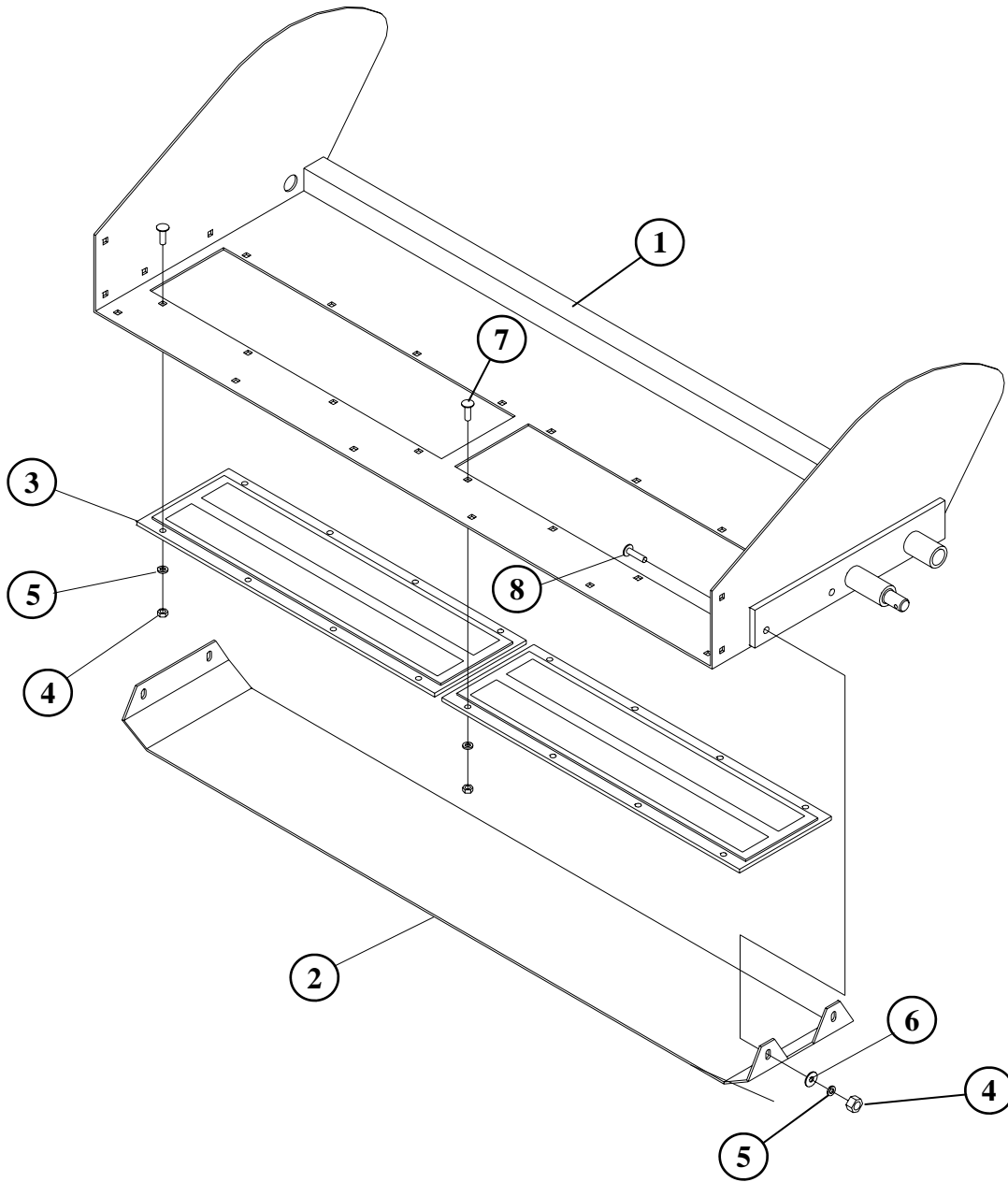

REF. NO	PART NO.	DESCRIPTION	QTY.
1A	850106	17" SPOUT WELDMENT.....	1
1B	850093	20" SPOUT WELDMENT.....	1
2	150299	SPOUT MAGNET GUARD.....	1
3	357005	ARCO PLATE MAGNET AM 2200.....	2
4	400205	HEX NUT, 5/16"-18.....	20
5	402005	LOCKWASHER, 5/16".....	20
6	402405	FLAT WASHER USS, 5/16".....	4
7	407021	CARRIAGE BOLT, 5/16"-18 x 1".....	18
8	407022	CARRIAGE BOLT, 5/16"-18 x 1-1/4".....	2

SPOUT RUBBER

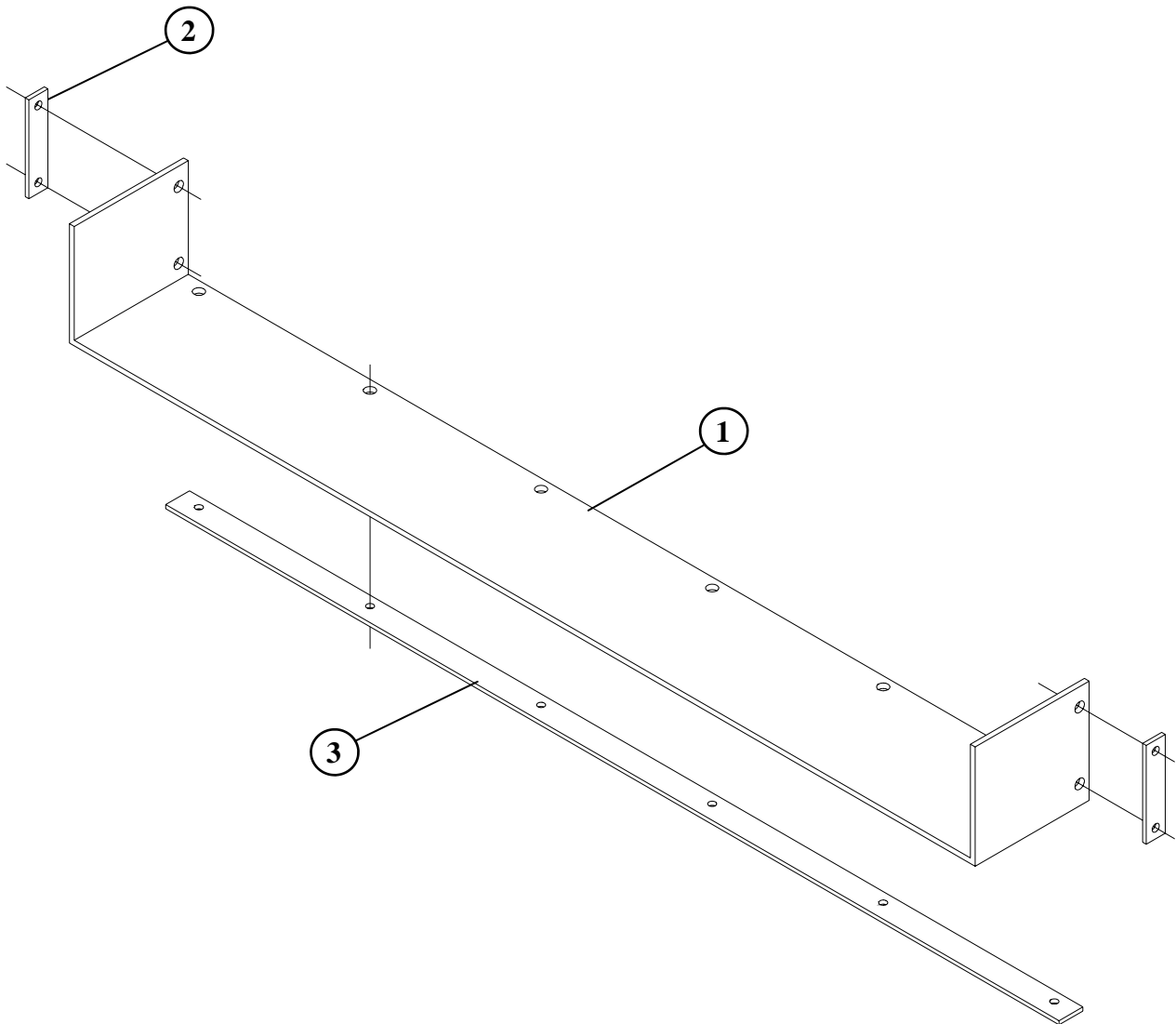

REF. NO	PART NO.	DESCRIPTION	QTY.
1			
A	150384	SPOUT RUBBER (17" SPOUT)	1
B	150403	SPOUT RUBBER (20" SPOUT)	1
2	150150	SPOUT RUBBER END PLATE	2
3	183152	SPOUT BACK-UP ANGLE	1

CHAIN CONVEYOR ASSEMBLY

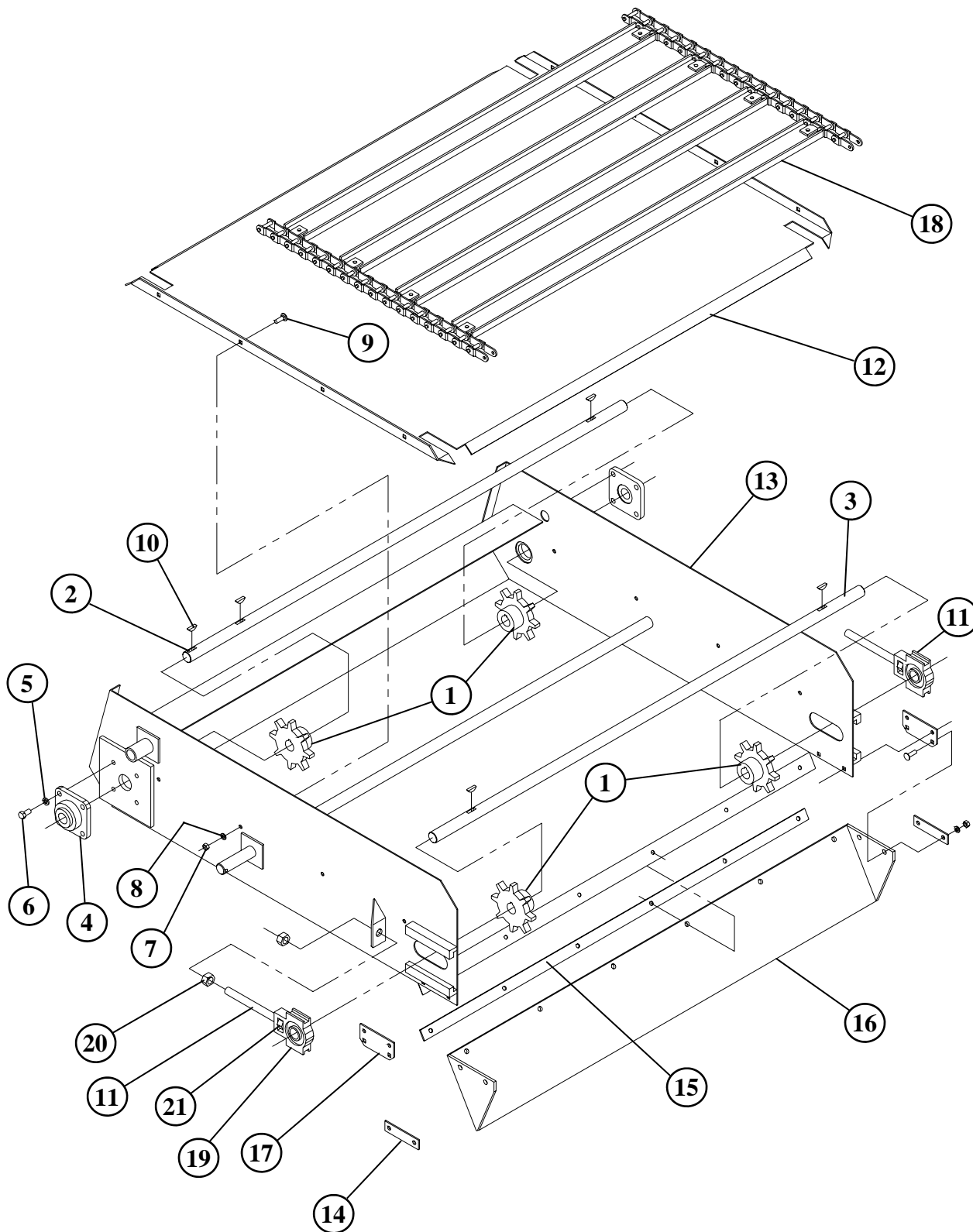

CHAIN CONVEYOR ASSEMBLY

#781414 24”L x 48”W CONVEYOR ASSEMBLY
#781464 36”L x 48”W CONVEYOR ASSEMBLY
#781465 48”L x 48”W CONVEYOR ASSEMBLY

REF. NO	PART NO.	DESCRIPTION	QTY.
1	160025	8 TOOTH #55 SPROCKET x 1”ID	4
2	188427	48”W CONVEYOR DRIVE SHAFT	1
3	188428	48”W CONVEYOR IDLER SHAFT.....	1
4	340316	RCJC 1” 4-BOLT FLANGE BEARING	2
5	402006	SPLIT LOCKWASHER, 3/8”	8
6	405652	HHCS, 3/8”-16 x 3/4”	8
7	400205	HEX NUT, 5/16”-18	20
8	402005	SPLIT LOCKWASHER, 5/16”	20
9	407021	CARRIAGE BOLT, 5/16”-18 x 1”	20
10	409916	WOODRUFF KEY, 1/4” x 1”.....	4
11	188390	CONVEYOR TAKE-UP BOLT.....	2
12	874126	24”L x 48”W CONVEYOR PAN WELDMENT	
	874004	36”L x 48”W CONVEYOR PAN WELDMENT	
	874122	48”L x 48W CONVEYOR PAN WELDMENT	1
13	874128	24”L x 48”W CONVEYOR WELDMENT	
	874136	36”L x 48”W CONVEYOR WELDMENT	
	874124	48”L x 48”W CONVEYOR WELDMENT	1
14	188304	CONVEYOR SPOUT RUBBER BAR - 4”	2
15	188384	CONVEYOR SPOUT RUBBER BAR - 45-3/4”	1
16	188432	48”W CONVEYOR SPOUT RUBBER.....	1
17	188418	CONVEYOR SPOUT RUBBER SIDE BAR	2
18	874127	24”L x 48”W CONV. C55 CHAIN WELDMENT	
	874154	36”L x 48”W CONV. C55 CHAIN WELDMENT	
	874153	48”L x 48”W CONV. C55 CHAIN WELDMENT	1
19	341323	TAKE-UP BEARING, 1”	2
20	400210	HEX NUT, 5/8”-11	6
21	400810	UNILOCK, 5/8”-11	2
22	760000	TAKE-UP BEARING ASSY (INCLUDES 11, 19 & 21).....	2

CHAIN CONVEYOR HYDRAULIC ASSEMBLY

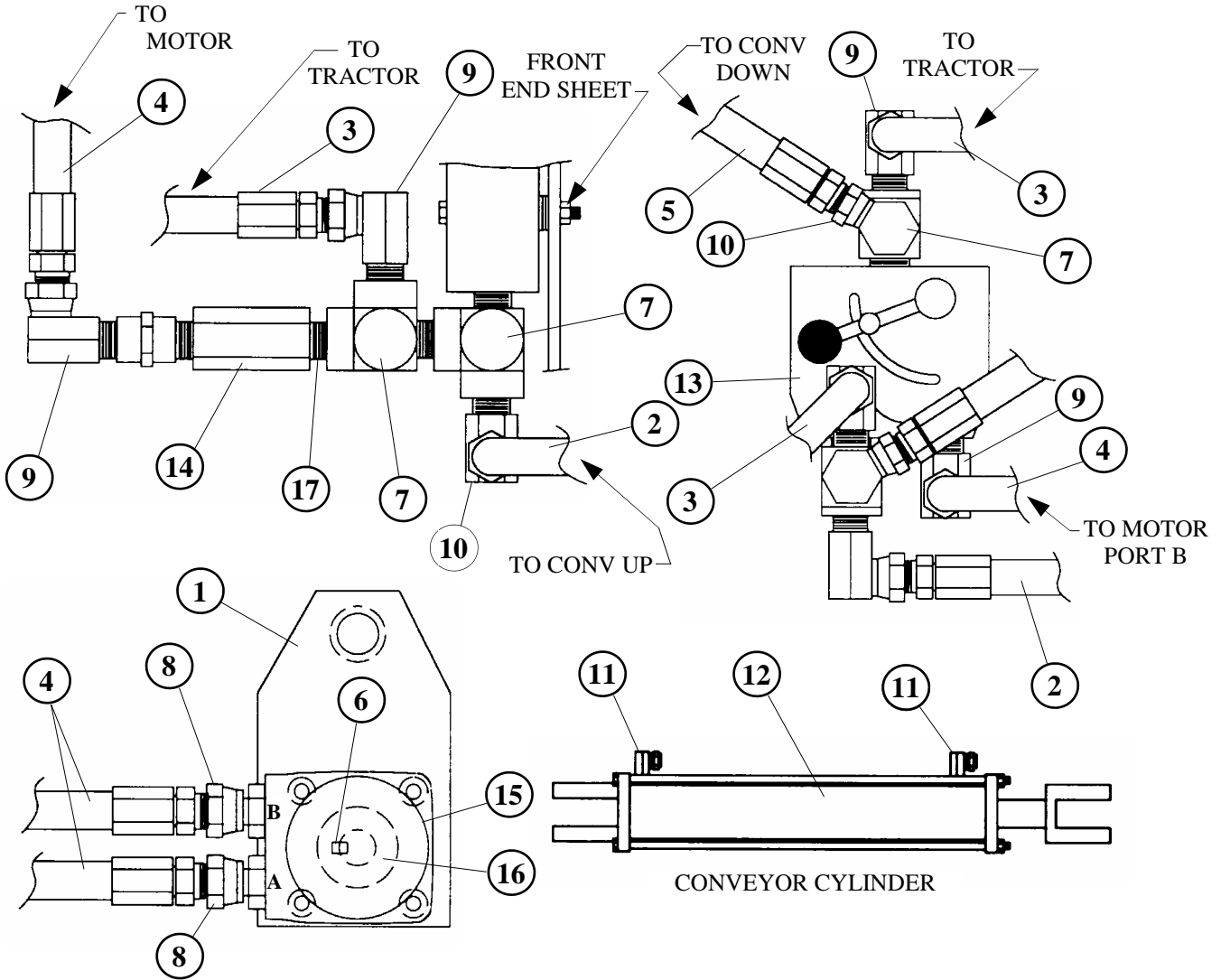

REF. NO	PART NO.	DESCRIPTION	QTY.
1	874071	CONVEYOR MOTOR PLATE WELDMENT	1
2	781329	HYD. HOSE ASSY 3/8" X 125" (3/8"MP ENDS)	1
3	781328	HYD. HOSE ASSY 1/2" X 128" (1/2"MP ENDS)	2
4	781327	HYD. HOSE ASSY 1/2" X 56" (1/2"MP ENDS)	2
5	781236	HYD. HOSE ASSY 3/8" X 112" (3/8"MP ENDS)	1
6	409916	WOODRUFF KEY 1/4" X 1"	1
7	368608	FITTING, 1/2"MP X 1/2"FP X 1/2"FP TEE	3
8	368118	FITTING, 7/8"MOR X 1/2"FPSW	2
9	368031	FITTING, 1/2"MP X 1/2"FPSW 90°	4
10	368028	FITTING, 1/2" X 3/8"FPSW	2
11	368007	FITTING, 3/8"MP X 3/8"FPSW 90° .109" ORFICE	2
12	364060	HYDRAULIC CYLINDER 2" X 16"	1
13	362283	HYDRAULIC FLOW CONTROL VALVE.....	1
14	362240	BALL CHECK VALVE 1/2"FP X 1/2"FP	1
15	360009	HYDRAULIC MOTOR, 9.7 CI	1
16	332654	KEY, 1"ID X 2"OD X 3"LTB CPLG W/1/4"	1
17	310805	CLOSE NIPPLE, 1/2"	1

CONVEYOR HYDRAULIC ASSEMBLY (TWO CYLINDERS)

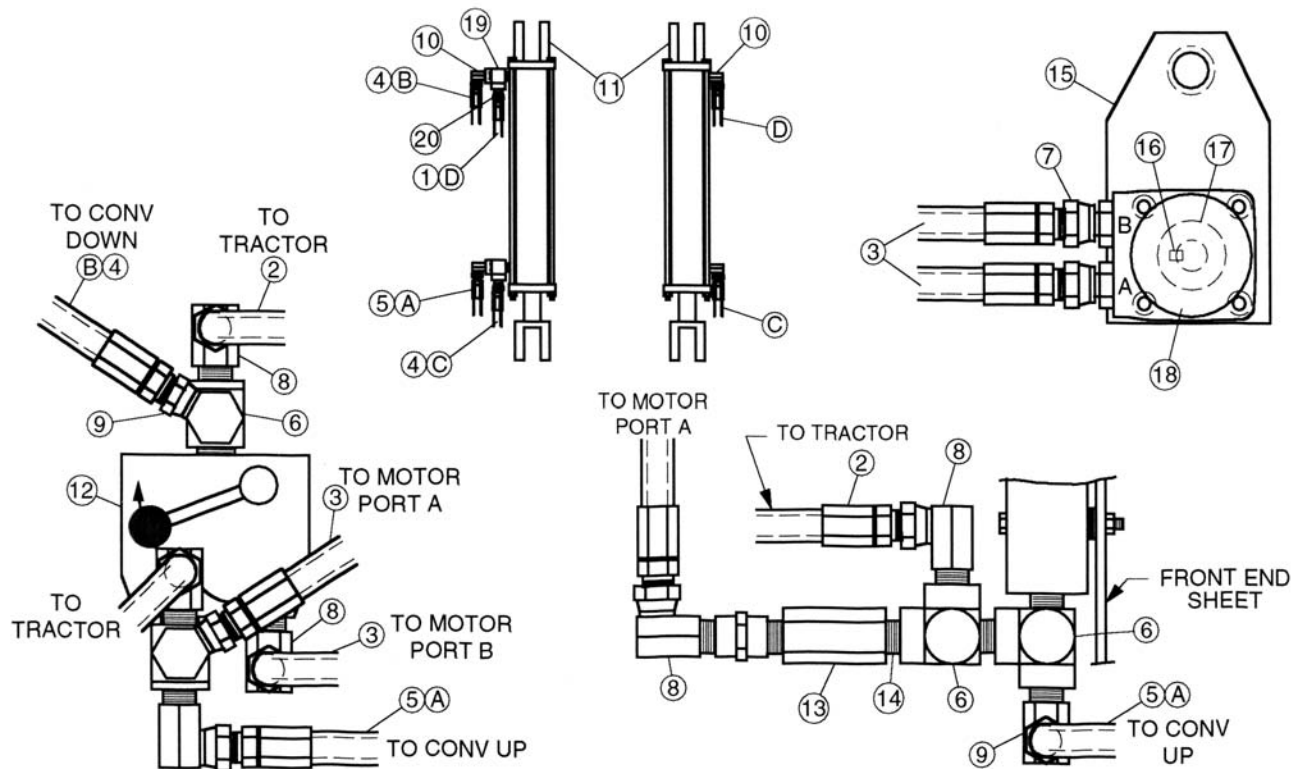

REF. NO	PART NO.	DESCRIPTION	QTY.
1	781355	HYD HOSE ASSY 3/8" x 105" (3/8" MP ENDS).....	1
2	781328	HYD. HOSE ASSY 1/2" x 128" (1/2"MP ENDS).....	2
3	781337	HYD. HOSE ASSY 1/2" x 80" (1/2"MP ENDS).....	2
4	781356	HYD. HOSE ASSY 3/8" x 81" (3/8"MP ENDS).....	2
5	781067	HYD. HOSE ASSY 3/8" x 60" (3/8"MP ENDS).....	1
6	368608	SERVICE TEE, 1/2"MP x 1/2"FP x 1/2"FP.....	3
7	368118	STRT. ADAPTER, 7/8"MOR x 1/2"FPS.....	2
8	368031	FITTING, 1/2"MP x 1/2"FPSW 90°.....	4
9	368028	FITTING, 1/2" x 3/8"FPSW 90°.....	2
10	368007	FITTING, 3/8"MP x 3/8"FPSW 90° .109" ORFICE.....	4
11	364060	HYDRAULIC CYLINDER 2" x 16" - 26-1/4" CC.....	1
12	362283	HYDRAULIC FLOW CONTROL VALVE.....	1
13	362240	BALL CHECK VALVE 1/2"FP x 1/2"FP.....	1
14	310805	CLOSE NIPPLE, 1/2".....	1
15	874071	CONVEYOR MOTOR PLATE WELDMENT.....	1
16	409916	WOODRUFF KEY, 1/4" x 1".....	1
17	332654	MOTOR COUPLING, 1"ID x 2"OD x 3"LTB, W1/4" KEY..	1
18	360009	HYDRAULIC MOTOR, 9.7 CI.....	1
19	368607	SERVICE TEE, 3/8"MP x 3/8"FP x 3/8"FP.....	2
20	368110	STRT. ADAPTER, 3/8"MP x 3/8"FPSW.....	2

524-15 SCALE INDICATOR ASSEMBLY

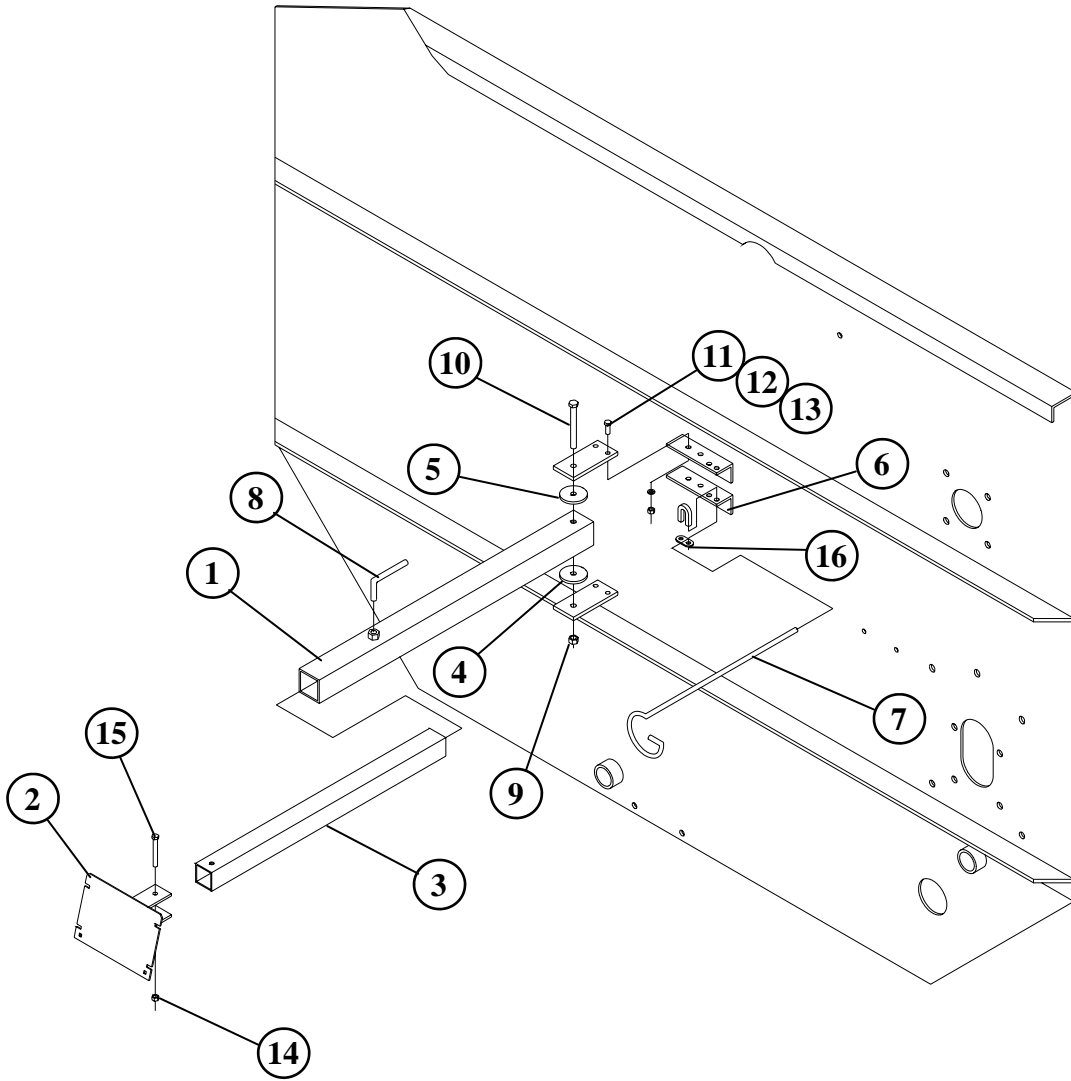

REF. NO	PART NO.	DESCRIPTION	QTY.
1	872125	TRAILER SCALE ARM WELDMENT	1
2	872126	TRAILER SCALE INDICATOR WELDMENT.....	1
3	185490	TRAILER SCALE INDICATOR TUBE.....	1
4	185491	HINGE PLATE.....	2
5	185493	HINGE WASHER.....	2
6	185303	TRAILER SCALE ARM ANGLE.....	2
7	184283	HOSE CARRIER	1
8	185492	LOCKING HANDLE 1/2".....	1
9	401108	HEX LOCKNUT, 1/2".....	1
10	405714	HHCS, 1/2" x 4-1/2"	1
11	400206	HEX NUT, 3/8".....	4
12	402006	LOCKWASHER, 3/8"	4
13	405653	HHCS, 3/8" x 1".....	4
14	400906	HEX LOCKNUT, 3/8".....	4
15	405661	HHCS, 3/8" x 3".....	1
16	412205	CABLE CLAMP, 3/8"	1

524-15 OIL BATH DOOR ASSEMBLY

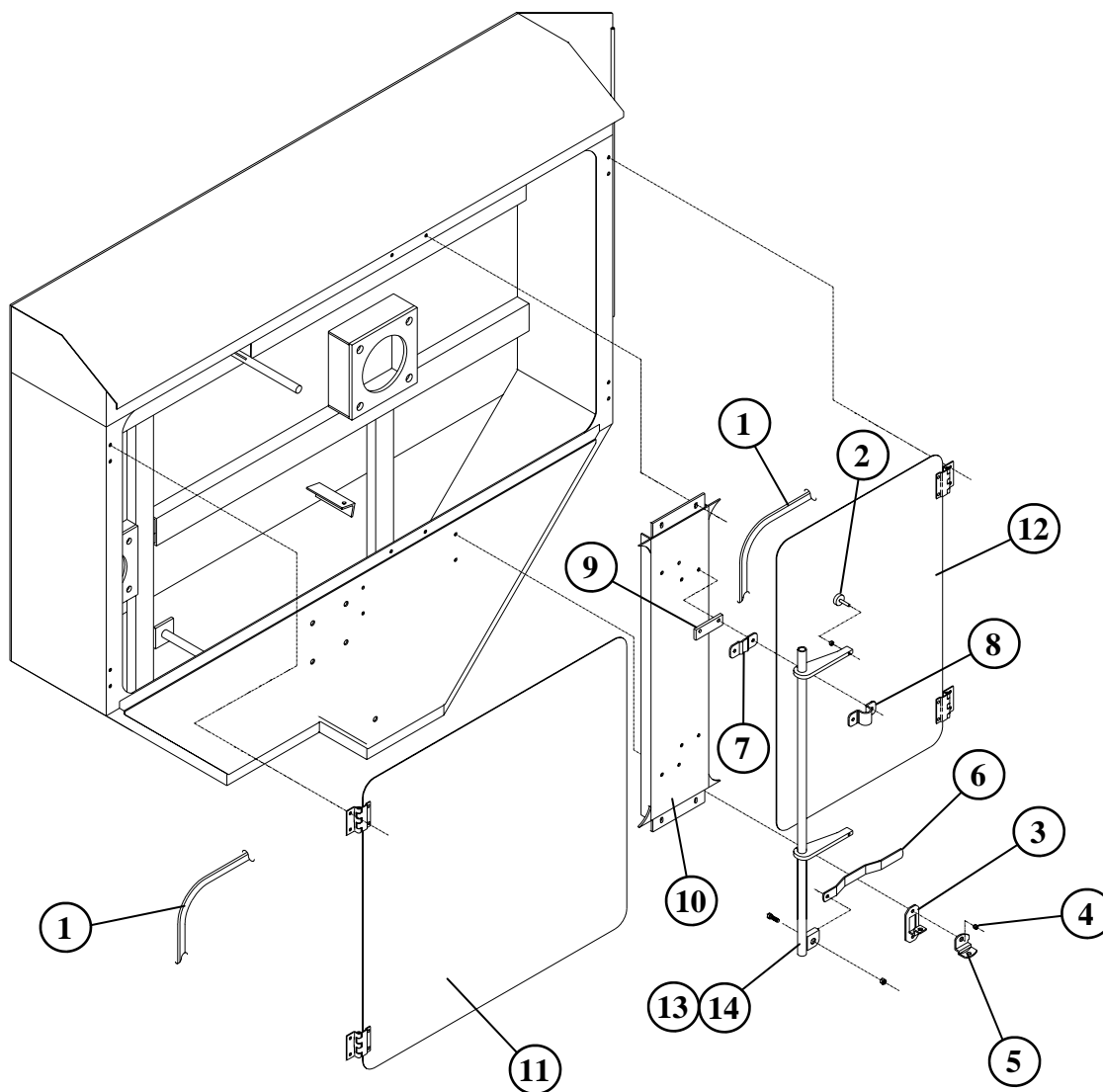

REF. NO	PART NO.	DESCRIPTION	QTY.
1	351056	RUBBER BULB SEAL, 5/32"	27'
2	370323	LEVELING PAD	4
3	370322	HANDLE STOP.....	2
4	370321	CAM LOCK BUSHING	2
5	370320	HANDLE CAM LOCK.....	2
6	370319	CAM LOCK HANDLE.....	2
7	370317	CAM LOCK BOTTOM PLATE.....	4
8	370316	CAM LOCK TOP PLATE	4
9	189503	CAM LOCK SPACER.....	4
10	872639	OIL BATH CENTER CHANNEL.....	1
11	850585	524 LARGE OIL BATH DOOR.....	1
12	850586	514 SMALL OIL BATH DOOR.....	1
13	850575	CAM ROD, LEFT DOOR.....	1
14	850574	CAM ROD, RIGHT DOOR.....	1

524-15 LUBRICATION ASSEMBLY

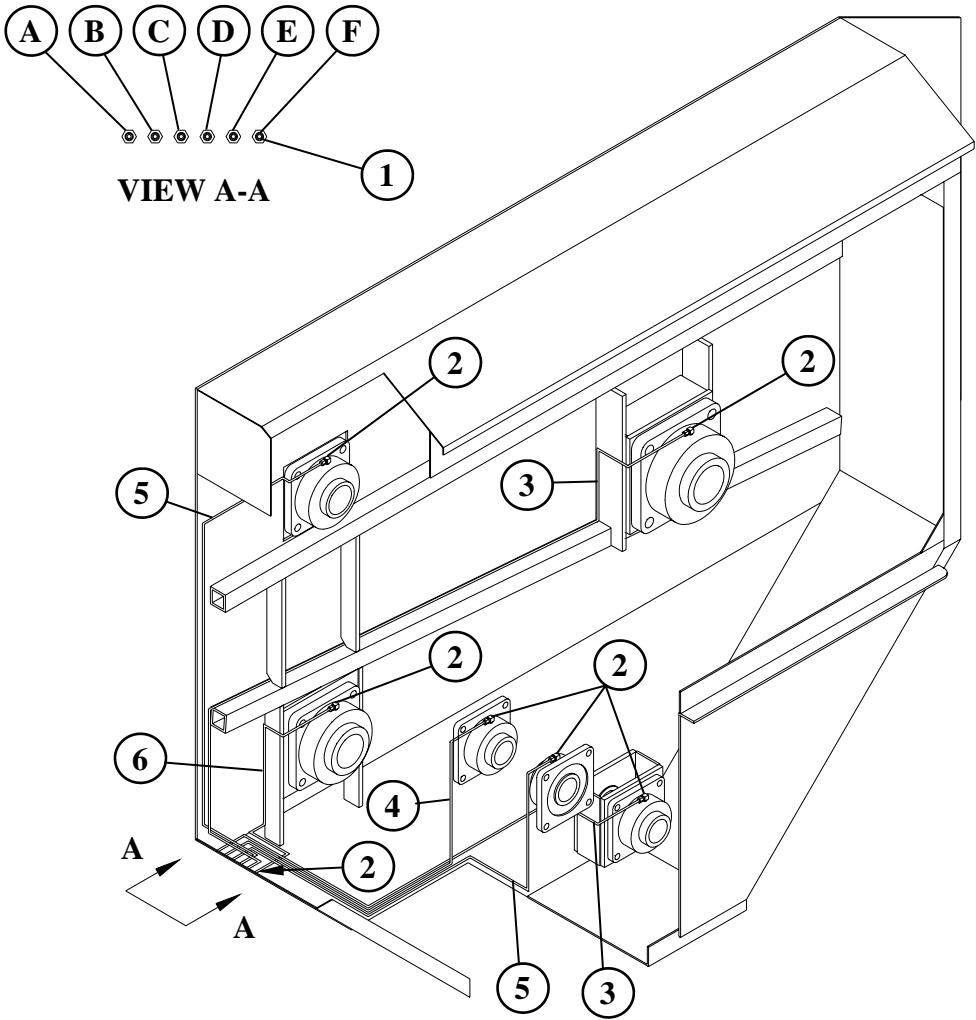

REF. NO	PART NO.	DESCRIPTION	QTY.
1	310750	1/8" PTF GREASE ZERK	6
2	356001	1/8" NFPT x 3/16" COMP. 90°.....	12
3	150212	3/16" COPPER GREASE LINE X 69".....	2
A		INPUT SHAFT BEARING	
E		ROTOR BEARING	
4	185044	3/16" COPPER GREASE LINE X 39".....	1
B		FRONT JACKSHAFT BEARING	
5	185341	3/16" COPPER GREASE LINE X 48".....	2
C		REAR JACKSHAFT BEARING	
D		TOP AUGER BEARING	
6	150211	3/16" COPPER GREASE LINE X 18".....	1
F		BOTTOM AUGER BEARING	

524-15 STAGGERED ROTOR ASSEMBLY

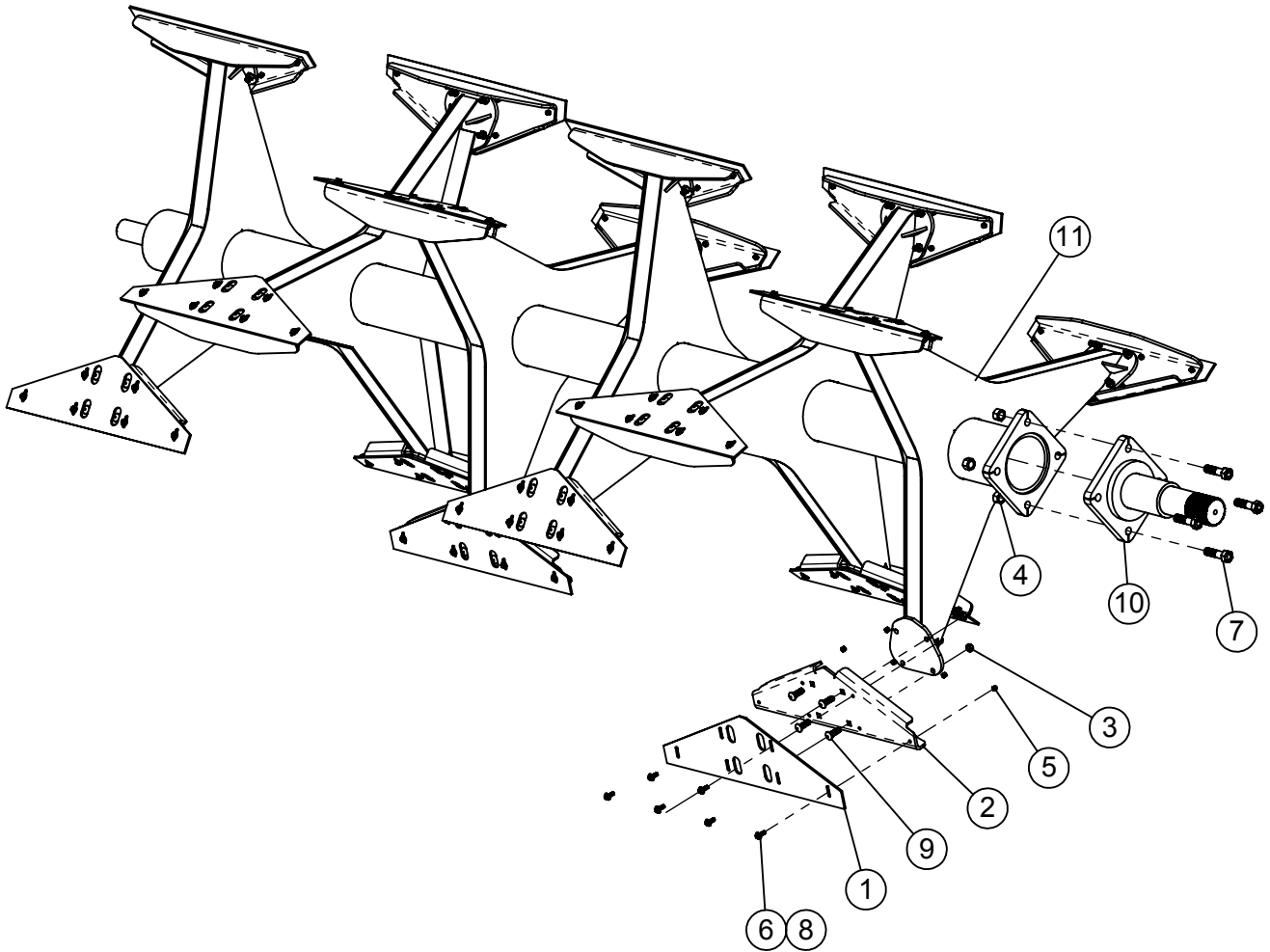

ITEM #	PART #	DESCRIPTION	QTY.
1	190339P	PLASTIC WIPER	18
2	190770	WIPER CHANNEL 5/8 BOLTS	18
3	400910	HEX CROWN LOCKNUT 5/8"-11 #9 PLTD	72
4	400916	HEX CROWN LOCKNUT, 1"-8 #5 PLTD	4
5	401106	HEX NUT, 3/8"-16 NYLOC #5 PLTD	108
6	402806	FLAT WASHER 3/8" #9 BOWMALLOY	108
7	406528	HHCS 1"-8 x 3-3/4" #8 PLTD	4
8	406906	HHCS 3/8"-16 x 1-1/4" #9 BOWMALLOY	108
9	407130	CHCS 5/8"-11 x 2" #8 PLTD	72
10	850544	524 ROTOR SHAFT FLANGE WA	1
11	872947	524-15 STAGGERED ROTOR WA	1

**3 ARM ROTOR ASSEMBLY
(FROM SERIAL #890573481 TO PRESENT)**

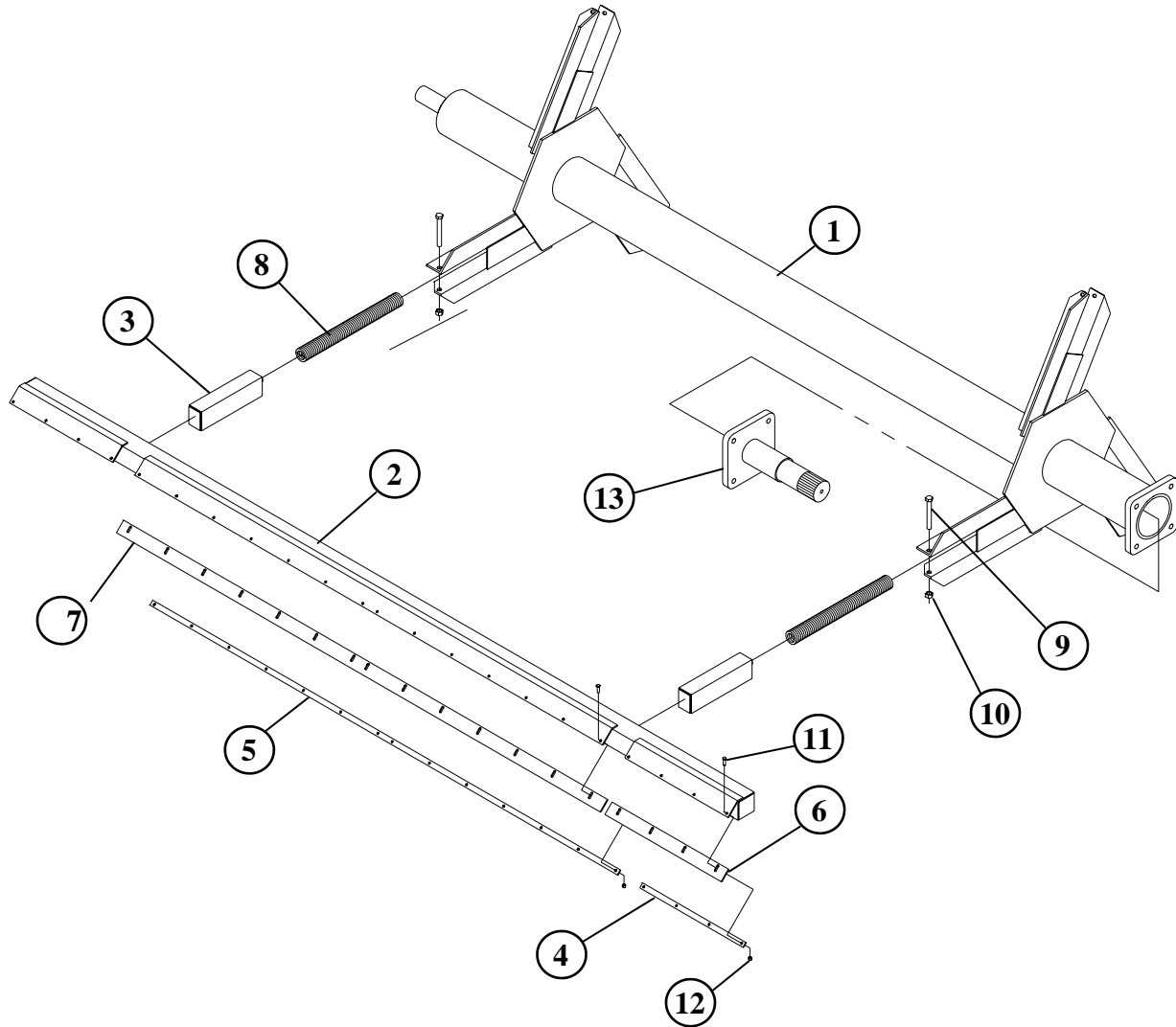

REF. NO	PART NO.	DESCRIPTION	QTY.
1	850122	524 3-ARM ROTOR WELDMENT	1
2	850125	524 WIPER TUBE WELDMENT	3
3	850007	ROTOR SPRING COVER WELDMENT	6
4	150344	END WIPER STRAP	6
5	150343	CENTER WIPER STRAP.....	3
6	150346	END PLASTIC WIPER	6
7	150345	CENTER PLASTIC WIPER.....	3
8	410005	2 1/2" X 24" X .410" COMPRESSION SPRING.....	6
9	406489	3/4"-10 x 6" HHCS	6
10	400912	3/4"-10 HEX CTR LOCKNUT.....	6
11	401106	3/8"-16 NYLOCK HEX NUT.....	66
12	405654	3/8"-16 x 1-1/4" HHCS	66
13	850544	ROTOR SHAFT FLANGE WELDMENT	1
14	750030	WIPER ASSEMBLY (INCLUDES #'s 2,4,5,6,7,11& 12)	3

**5 ARM ROTOR ASSEMBLY
(FROM SERIAL #890573481 TO PRESENT)**

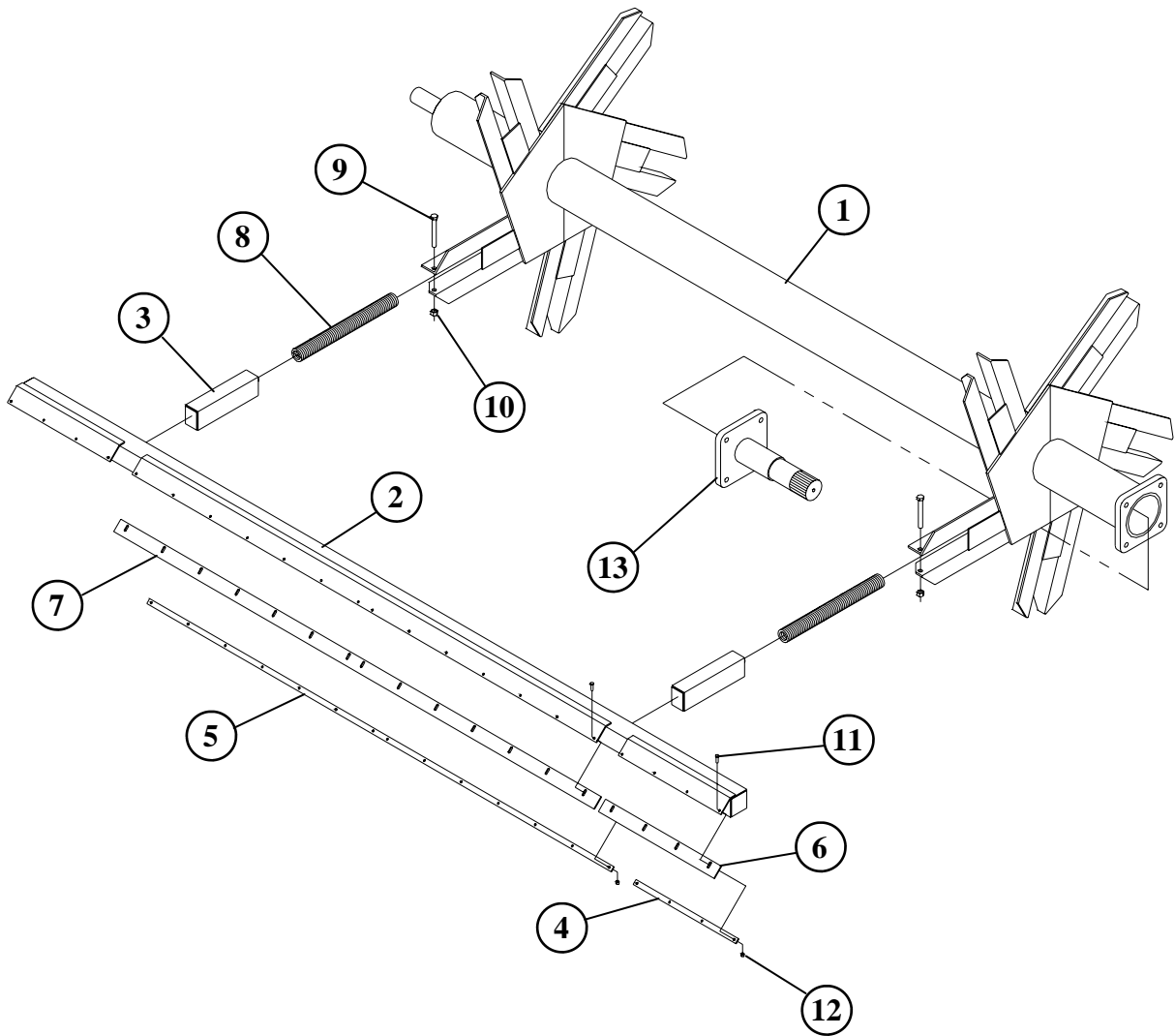

REF. NO	PART NO.	DESCRIPTION	QTY.
1	850248	524 5-ARM ROTOR WELDMENT	1
2	850125	524 WIPER TUBE WELDMENT	5
3	850007	ROTOR SPRING COVER WELDMENT	10
4	150344	END WIPER STRAP	10
5	189343	CENTER WIPER STRAP.....	5
6	150346	END PLASTIC WIPER	10
7	150345	CENTER PLASTIC WIPER.....	5
8	410005	2 1/2" x 24" X .410" COMPRESSION SPRING	10
9	406489	5/8"-10 x 6" HHCS	10
10	400912	3/4"-10 HEX CTR LOCKNUT.....	10
11	401106	3/8"-16 NYLOCK HEX NUT.....	110
12	405654	3/8"-16 x 1-1/4" HHCS.....	110
13	850544	ROTOR SHAFT FLANGE WELDMENT	1
14	750030	WIPER ASSEMBLY (INCLUDES #'s 2,4,5,6,7,11 &12).....	5

**524 TOP & BOTTOM AUGER ASSEMBLIES
(FROM SERIAL #890573481 TO PRESENT)**

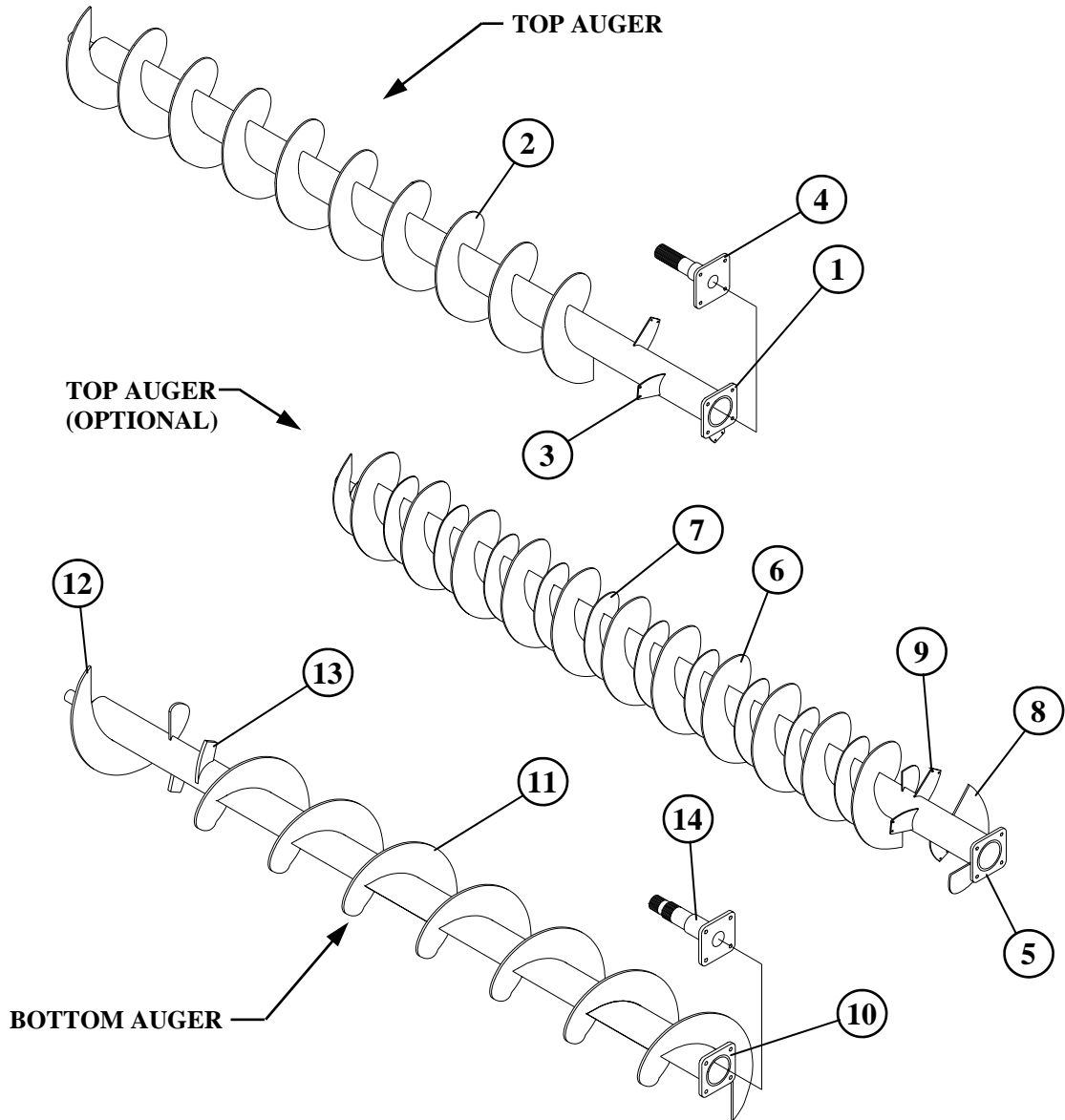

REF. NO	PART NO.	DESCRIPTION	QTY.
1	850131	TOP AUGER 3/8" FLIGHT WELDMENT	1
2	382026	FLIGHT RH 20"OD x 6 5/8"ID x 3/8" x 14" PITCH	9-1/2
3	150126	TOP AUGER PADDLE	3
4	850542	TOP AUGER SHAFT FLANGE WELDMENT	1
5	850131B	TOP AUGER DOUBLE FLIGHT WELDMENT	1
6	382026	FLIGHT RH 20"OD x 6-5/8"ID x 3/8" x 14" PITCH	11
7	381625	FLIGHT RH 16"OD x 6-5/8"ID x 1/4" x 14" PITCH	11
8	382023	FLIGHT LH 20"OD x 6-5/8"ID x 3/8" x 20" PITCH	1/2
9	150126	TOP AUGER PADDLE	3
10	850127	BOTTOM AUGER 1/2" FLIGHT WELDMENT	1
11	382021	FLIGHT LH 20"OD x 6-5/8"ID x 1/2" x 20" PITCH	7
12	382020	FLIGHT RH 20"OD x 6-5/8"ID x 1/2" x 20" PITCH	1
13	150411	20" AUGER KICKER	2
14	850543	BOTTOM AUGER SHAFT FLANGE WELDMENT	1

**524 FRONT END ASSEMBLY
(FROM SERIAL #890573481 TO PRESENT)**

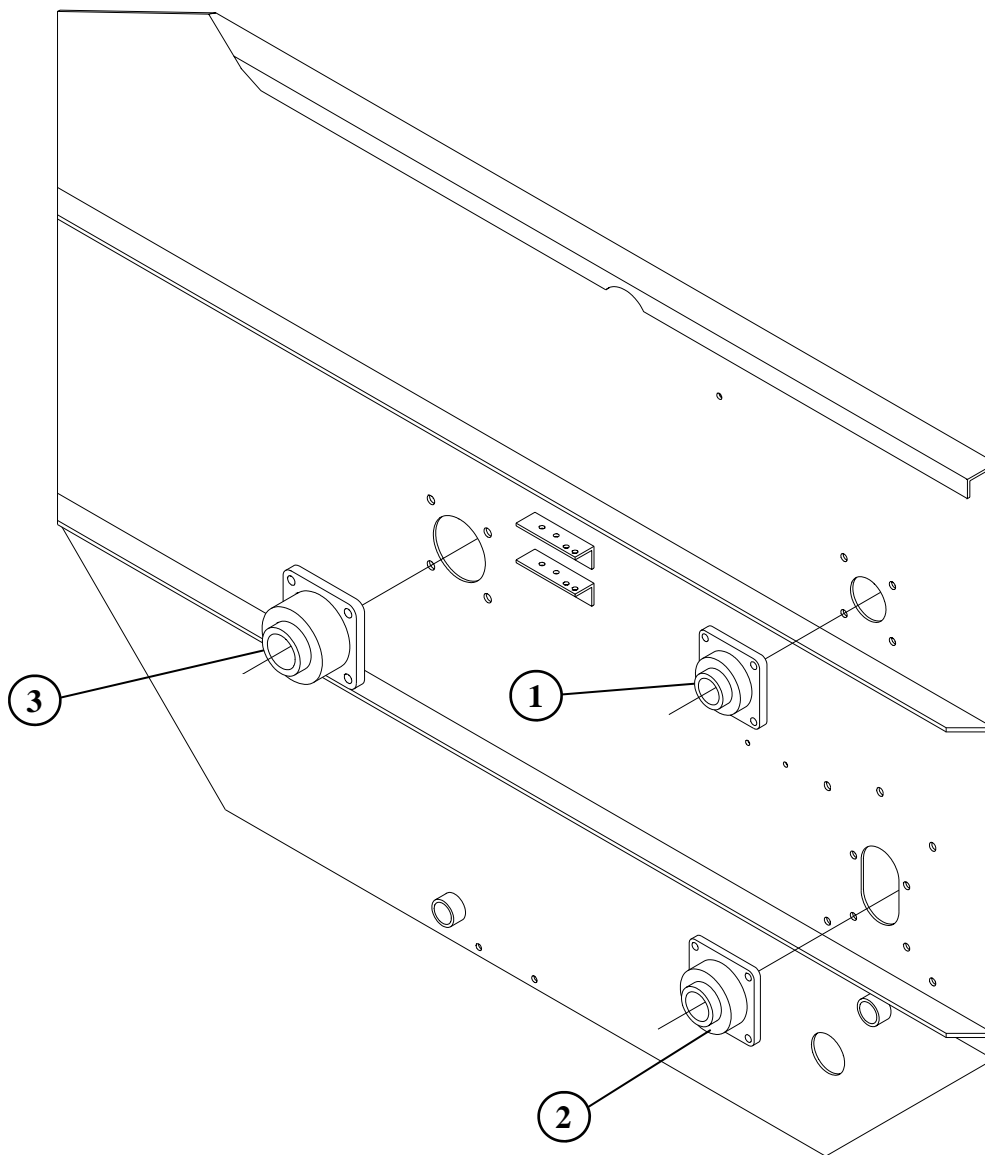

REF. NO	PART NO.	DESCRIPTION	QTY.
1	340436	LB F3Y235N 2-3/16" 4-BOLT FLANGE BEARING	1
2	340437	LB F3Y239N 2-7/16" 4-BOLT FLANGE BEARING	1
3	340446	LB F247 2-15/16" 4-BOLT FLANGE BEARING	1

524 DRIVE ASSEMBLY (FROM SERIAL #890573481 TO PRESENT)

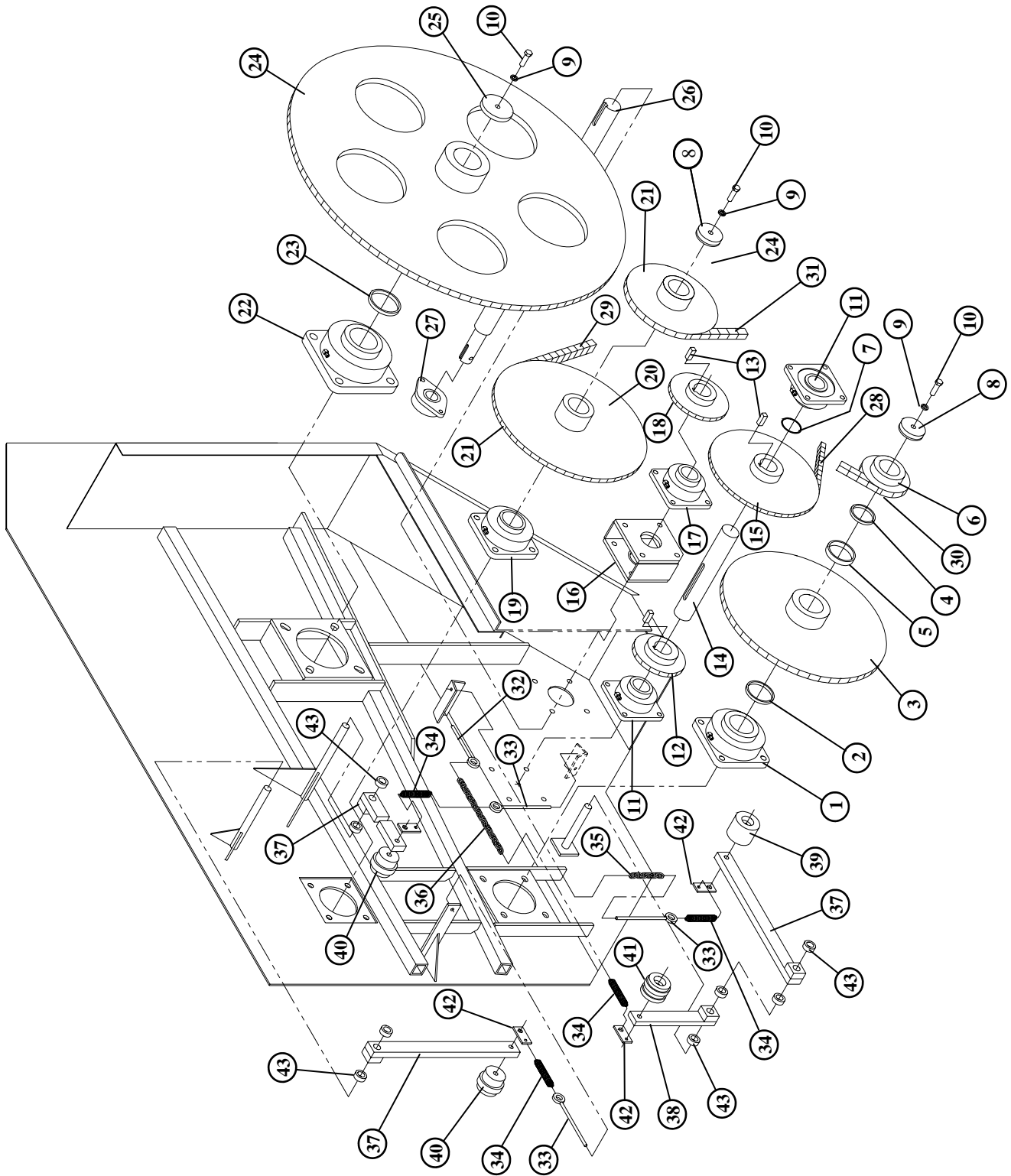

524 DRIVE ASSEMBLY (FROM SERIAL #890573481 TO PRESENT)

REF#	PART#	DESCRIPTION	QTY.
20	850521	#100 B 54 SPRKT WELDMENT	1
21	850520	#120 B 26 SPROCKET WELDMENT	1
22	340564	4" MSF 64 BEARING	1
23	185321	4" SHAFT SPACER 1/2	1
24	850518	#120 B 100 SPROCKET WELDMENT	1
25	185329	4-1/2" RETAINER	1
26	150369	524 INPUT SHAFT	1
27	340228	VCJT 1-3/4" 2-BOLT FLANGE BRG	1
28	320884	#80 RC x 84 PITCHES	1
29	321111	#100 RC x 111 PITCHES	1
30	321225	#120 RC x 125 PITCHES	1
31	321275	#120 RC x 75 PITCHES	1
32	410851	3/8" x 6" EYEBOLT	1
33	410852	3/8" x 8" EYEBOLT	3
34	410012	1-3/4" x 7" PULL SPRING	4
35	185487	2/0 PASSING LINK CHAIN x 3	1
36	185488	2/0 PASSING LINK CHAIN x 18	1
37	872252	IDLER ARM WELDMENT 23-3/4	3
38	872254	IDLER ARM WELDMENT 13	1
39	185582	IDLER BLOCK 3-1/2"OD UHMW	1
40	185621	#120 IDLER BLOCK UHMW	2
41	187159	#100 IDLER BLOCK UHMW	1
42	187157	PULL TAB	4
43	412416	1" SET COLLAR	8

REF#	PART#	DESCRIPTION	QTY.
1	340556	3-1/2" MSF 56 4-BOLT FLANGE BRG	1
2	189545	3-1/2" SHAFT SPACER-13/32	1
3	850519	#120 B 48 SPROCKET WELDMENT	1
4	189546	3" SHAFT SPACER-3/8	1
5	185319	3-1/2" SHAFT SPACER-1/2	1
6	331213	#120 B 13H SPROCKET	1
7	150599	2-1/2" SHAFT SPACER-1/16	1
8	850129	3-1/2" RETAINER WELDMENT	2
9	402010	5/8" LOCK WASHER	3
10	405754	5/8" x 2" HHCS	3
11	340438	2-7/16" RCJ 4-BOLT FLANGE BRG	2
12	331002	#100 B 17H SPRKT - 540 PTO TRK & TRL	1
13	331001	#100 B 15H SPRKT - 1000 PTO TRL	1
14	189104	5/8" SQ. KEY x 1-3/4	3
15	150363	JACKSHAFT	1
16	330849	#80 B 48 SPROCKET	1
17	781037	2-7/16" SEAL PLATE ASSEMBLY	1
A	355039	2-7/16" SEAL CR-24287	2
18	340439	2-7/16" RCJC 4-BOLT FLANGE BRG	1
19	330825	#80 B 25H SPRKT - 540 PTO TRK & TRL	1
20	330805	#80 B 15H SPRKT - 1000 PTO TRL	1
21	342048	3" REX MB 2300 BEARING 4-BOLT	1

524 DRIVE ASSEMBLY (BEFORE SERIAL #890573481)

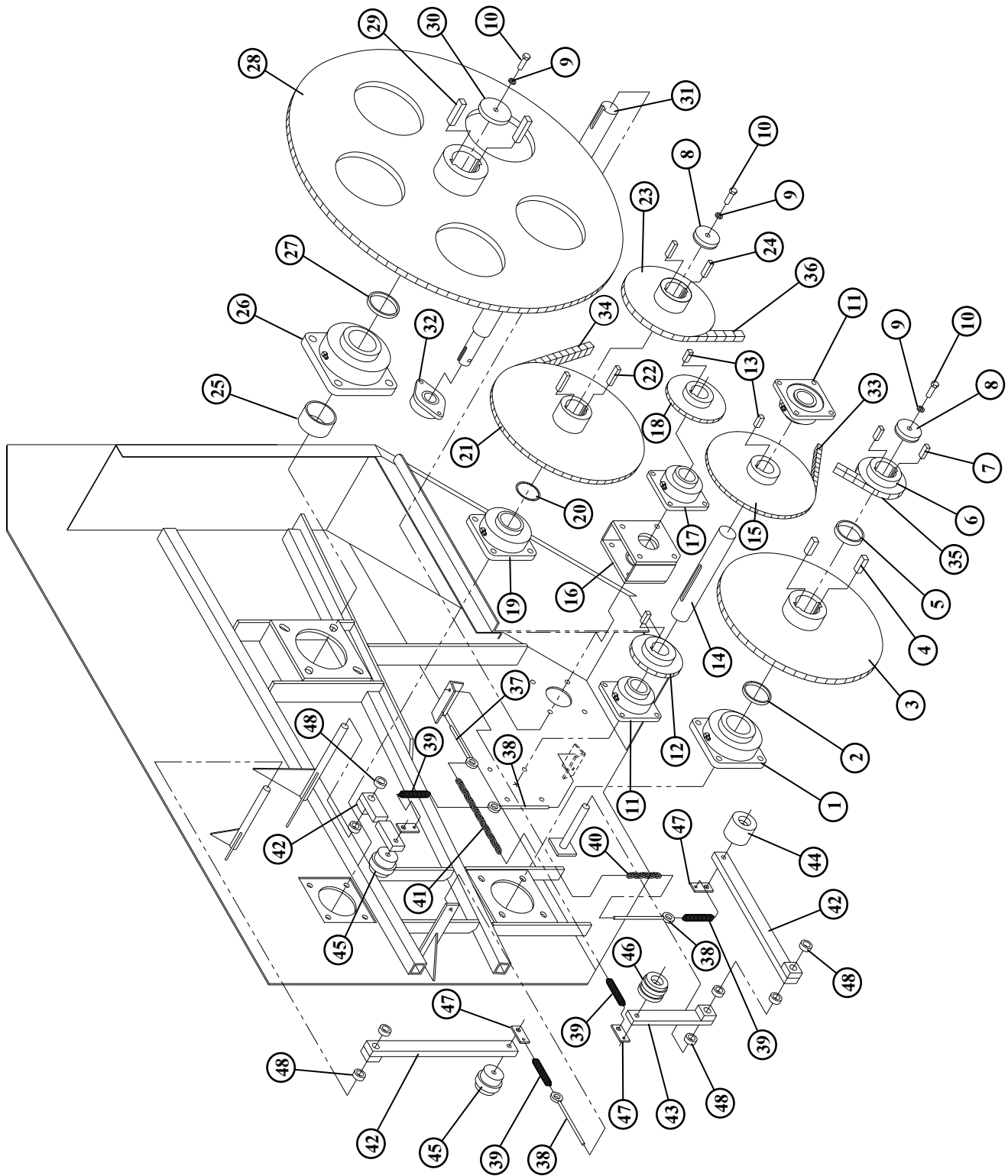

524 DRIVE ASSEMBLY (BEFORE SERIAL #890573481)

REF#	PART#	DESCRIPTION	QTY.	REF#	PART#	DESCRIPTION	QTY.
1	340556	3-1/2" MSF 56 4-BOLT FLANGE BRG	1	23	850134	#120 B 26 SPROCKET WELDMNT	1
2	150353	3-1/2" SHAFT SPACER-7/16	1	24	150079	1/2" x 3/4" RECT. KEY x 2-1/2	2
3	850130	#120 B 48 SPROCKET WELDMNT	1	25	150347	4" SHAFT SPACER 2-3/8	1
4	150373	3/4" x 7/8" RECT. KEY x 2-1/2	2	26	340564	4" MSF 64 BEARING	1
5	150354	3-1/2" SHAFT SPACER-23/321	1	27	185321	4" SHAFT SPACER 1/2	1
6	150358	#120 B 13H SPROCKET	1	28	850126	#120 B 100 SPROCKET WELDMNT	1
7	150356	1/2" x 3/4" RECT. KEY x 2	2	29	185285	3/4" x 1" RECT. KEY x 4	2
8	850129	3-1/2" RETAINER WELDMNT	2	30	185329	4-1/2" RETAINER	1
9	402010	5/8" LOCKWASHER	3	31	150369	524 INPUT SHAFT	1
10	405754	5/8" x 2" HHCS	3	32	340228	VCJT 1-3/4" 2-BOLT FLANGE BRG	1
11	340438	2-7/16" RCJ 4-BOLT FLANGE BRG	2	33	320884	#80 RC x 84 PITCHES	1
12	331002	#100 B 17H SPRKT - 540 PTO TRK & TRL	1	34	321111	#100 RC x 111 PITCHES	1
13	331001	#100 B 15H SPROCKET - 1000 PTO TRL ...	1	35	321225	#120 RC x 125 PITCHES	1
14	189104	5/8" SQ. KEY x 1-3/4	3	36	321275	#120 RC x 75 PITCHES	1
15	150363	JACKSHAFT	1	37	410851	3/8" x 6" EYEBOLT	1
16	330849	#80 B 48 SPROCKET	1	38	410852	3/8" x 8" EYEBOLT	3
17	781037	2-7/16" SEAL PLATE ASSEMBLY	1	39	410012	1-3/4" x 7" PULL SPRING	4
18	355039	2-7/16" SEAL CR-24287	2	40	185487	2/0 PASSING LINK CHAIN x 3	1
19	340439	2-7/16" RCJC 4-BOLT FLANGE BRG	1	41	185488	2/0 PASSING LINK CHAIN x 18	1
20	330825	#80 B 25H SPRKT - 540 PTO TRK & TRL	1	42	872252	IDLER ARM WELDMNT 23-3/4	3
21	330805	#80 B 15H SPROCKET - 1000 PTO TRL	1	43	872254	IDLER ARM WELDMNT 13	1
22	340548	3" MSF 48 BEARING	1	44	185582	IDLER BLOCK 3-1/2"OD UHMW	1
23	150033	3" SHAFT SPACER 1/32	1	45	185621	#120 IDLER BLOCK UHMW	2
24	850135	#100 B 54 SPROCKET WELDMNT	1	46	187159	#100 IDLER BLOCK UHMW	1
25	150517	1/2" x 3/4" RECT. KEY x 3	2	47	187157	PULL TAB	4
				48	412416	1" SET COLLAR	8

524 STATIONARY DRIVE ASSEMBLY

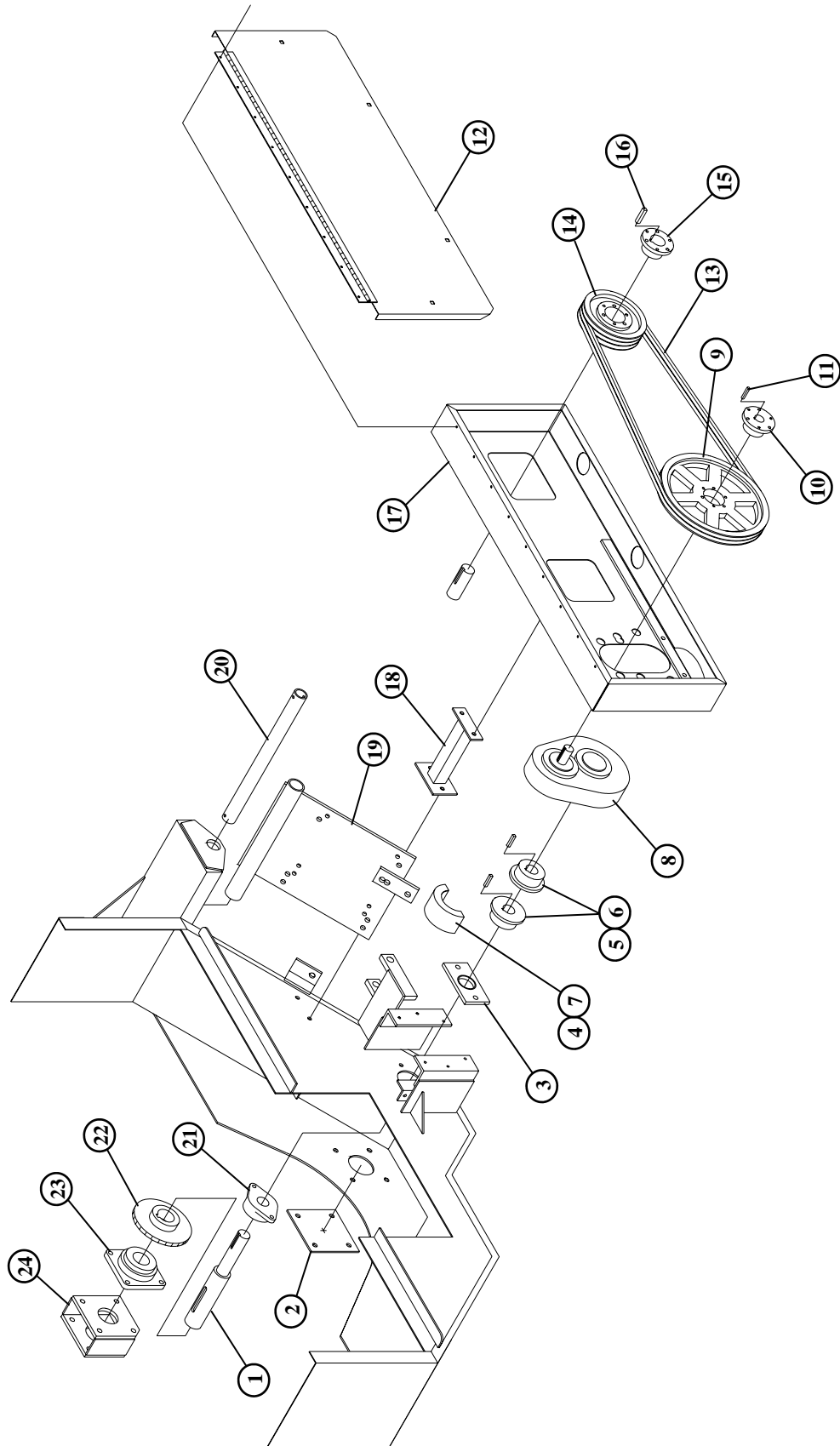

524 STATIONARY DRIVE ASSEMBLY

REF. NO	PART NO.	DESCRIPTION	QTY.
1	150395	524 ELECTRIC INPUT SHAFT - 17	1
2	185641	COVER PLATE	1
3	780015	1-3/4" SEAL PLATE ASSEMBLY	1
A	355028	1-3/4" GREASE SEAL	2
4	320720	#60-2 RC x 20 PITCHES COMP	1
5	332612	60 B 20 x 1-3/4" CHAIN COUPLING SPROCKET	2
6	185480	3/8" SQ. KEY x 2"	2
7	332614	6020 CHAIN COUPLING COVER	1
8	344023	3:1 HUB CITY GEARBOX	1
9	324016	5V-2 GROOVE 16.0" SF BELT SHEAVE	1
10	336022	SF 1-3/8" QD BUSHING	1
11	185484	5/16" SQ. KEY x 2"	1
12	781001	ELEC. BELT SHIELD DOOR ASSEMBLY	1
13	325106	5V-1060 V-BELT	2
14	324009	5V-3 GROOVE 9.25" SF BELT SHEAVE	1
15	336031	1-7/8" SQ BUSHING	1
16	185485	1/2" SQ. KEY x 2-1/2"	1
17	850149	524 ELEC BELT SHIELD WELDMENT	1
18	872003	ELEC. BELT SHIELD SUPPORT WELDMENT	1
19	850147	524 ELEC. MOTOR BASE WELDMENT 25-50	1
20	185087	ELEC. MOTOR PIVOT PIPE 24"	1
21	340228	VCJT 1-3/4" 2-BOLT FLANGE BEARING	1
22	330825	80 B 25H RC SPROCKET	1
23	340439	RCJC 2-7/16" 4-BOLT FLANGE BEARING	1
24	781037	INPUT BEARING MOUNT & SEAL ASSEMBLY	1
A	355039	CR-24287 2-7/16" ID SEAL	2

524 200 SERIES 3:1 GEARBOX ASSEMBLY (#344023)

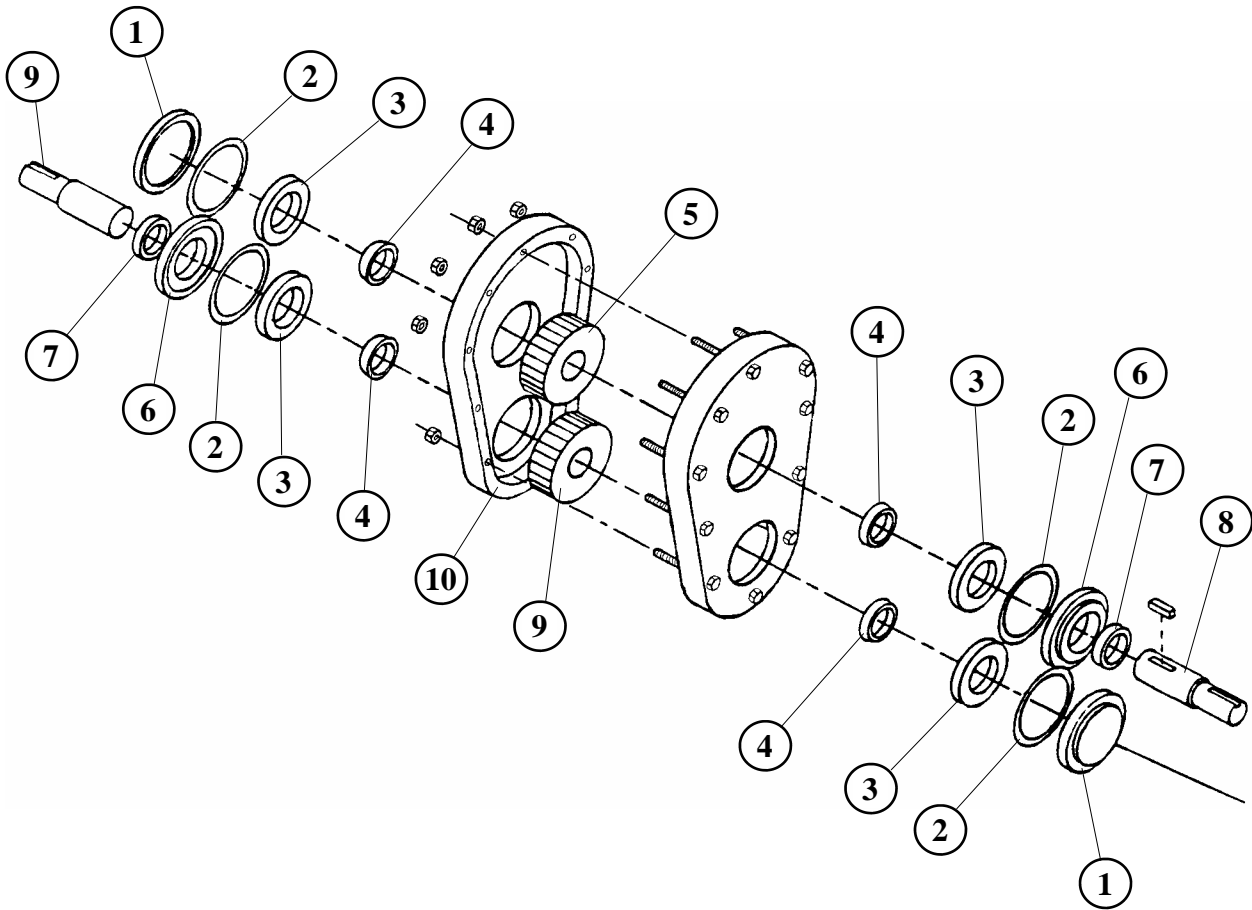

REF. NO	PART NO.	DESCRIPTION	QTY.
1	344214	CLOSED END CAP.....	2
2	344215	END CAP GASKET	4
3	344211	BOX BEARING CUP 18620	4
4	344210	GEARBOX BEARING 1-3/4" T-18690	4
5	344220	3:1 LOW SPEED GEAR.....	1
6	344213	OPEN END CAP 02-23-00166-400.....	2
7	344209	GEARBOX SEAL 1 3/4" CR 18039.....	2
8	344223	LOW SPEED SHAFT 1 3/4"	1
9	344219	3:1 1-3/8" HIGH SPEED SHAFT & GEAR COMPLETE.....	1
10	344212	CENTER CASE GASKET 02-23-00919-200.....	1

524 TRUCK DRIVELINE ASSEMBLY

ITEMS 1 & 5 ARE CUT TO LENGTH
AND WELDED AT INSTALLATION.

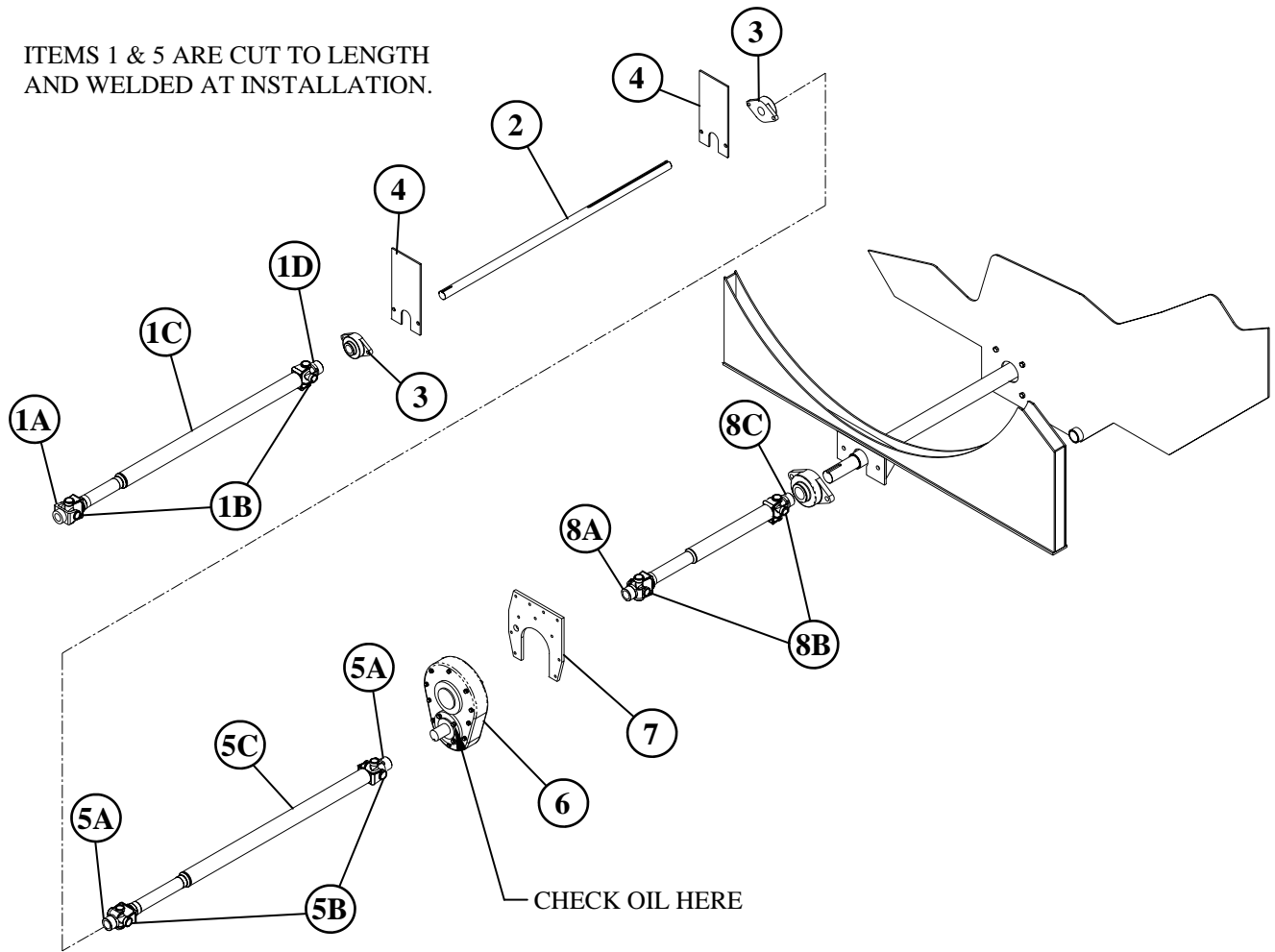

REF. NO	PART NO.	DESCRIPTION	QTY.
1	780486	1280 DRIVESHAFT ASSY. 1-1/4" x 1-3/8"	1
A	338420	1-1/4" SPICER YOKE.....	1
B	338435	SPICER 1280 CROSS KIT.....	2
C	338053	SPICER DRIVESHAFT SPLINE TUBE ASSY	1
D	338422	1-3/8" SPICER YOKE.....	1
2	183327	TRUCK JACKSHAFT 1-3/8".....	1
3	340221	1-3/8" FX3W222E 2-BOLT FLANGE BEARING	2
4	183319	TRUCK JACKSHAFT BRACKET	2
5	780494	1280 DRIVESHAFT ASSY 1-3/8" x 1-3/8"	1
A	338422	1-3/8" SPICER YOKE.....	2
B	338435	SPICER 1280 CROSS KIT.....	2
C	338053	SPICER DRIVESHAFT SPLINE TUBE ASSY	1
6	344023	3:1 HUB CITY GEARBOX.....	1
7	183251	GEARBOX PLATE	1
8	338042	W-2400 385560 DRIVESHAFT	1
A	338449	W-2400 YOKE 1-3/4" RB, 1/2 SET SCREW	1
B	338443	W-2400 312410 CROSS KIT	2
C	338451	W-2400 1-3/4" RB YOKE, SET SCREW & BOLT	1

524 TRUCK W-2400 DRIVESHAFT ASSEMBLY (#385560)

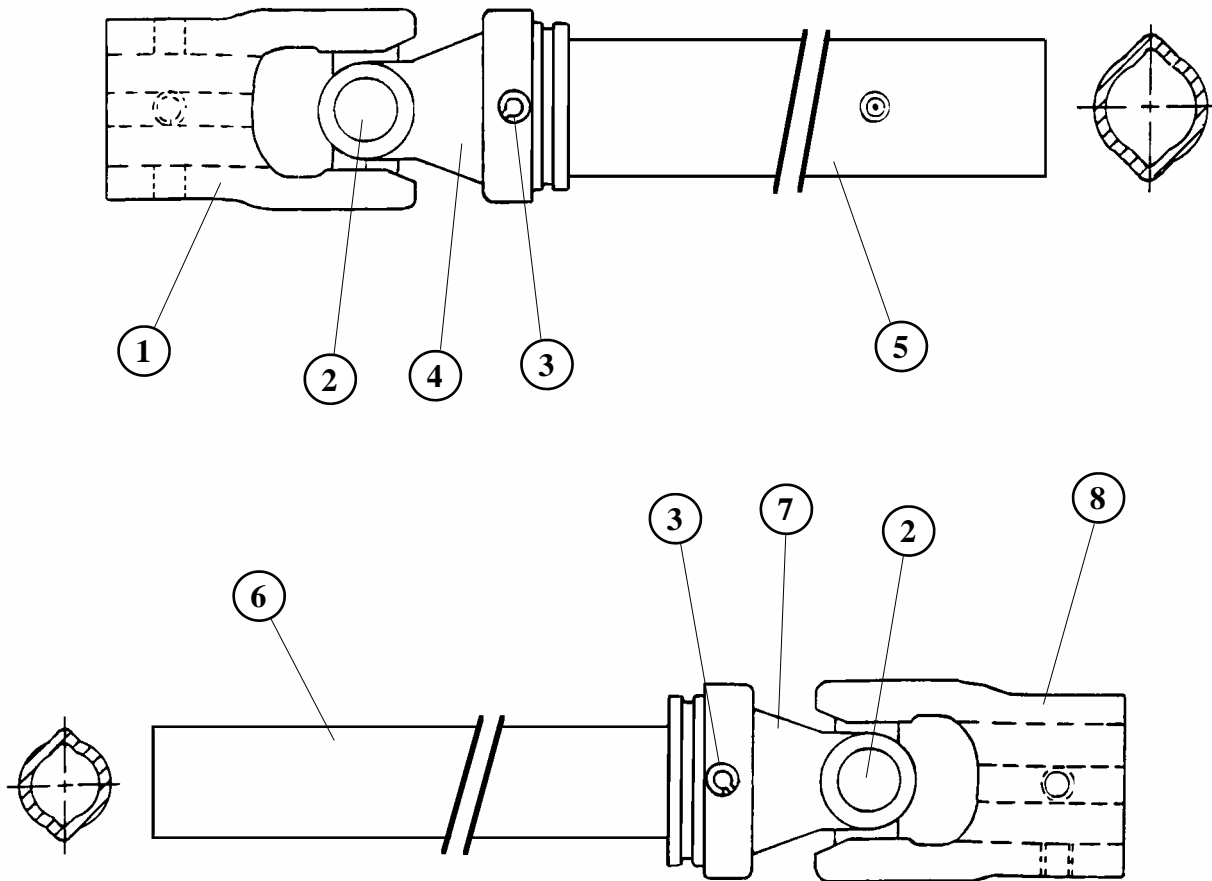

REF. NO	PART NO.	DESCRIPTION	QTY.
1	338451	W-2400 YOKE 1-3/4"RB 3/8" KEYWAY	1
2	338443	W-2400 CROSS KIT	2
3	338473	WALTERSHIED #10 METRIC ROLL PIN.....	2
4	338450	W-2400 INBOARD YOKE	1
5	338447	W-2400 OUTER PROFILE 2aL	1
6	338448	W-2400 INNER PROFILE 1b.....	1
7	338452	W-2400 INBOARD YOKE 2A	1
8	338449	W-2400 YOKE 1-3/4"RB 3/8" KEYWAY	1

540 & 1000 TRAILER PTO DRIVELINE ASSEMBLY

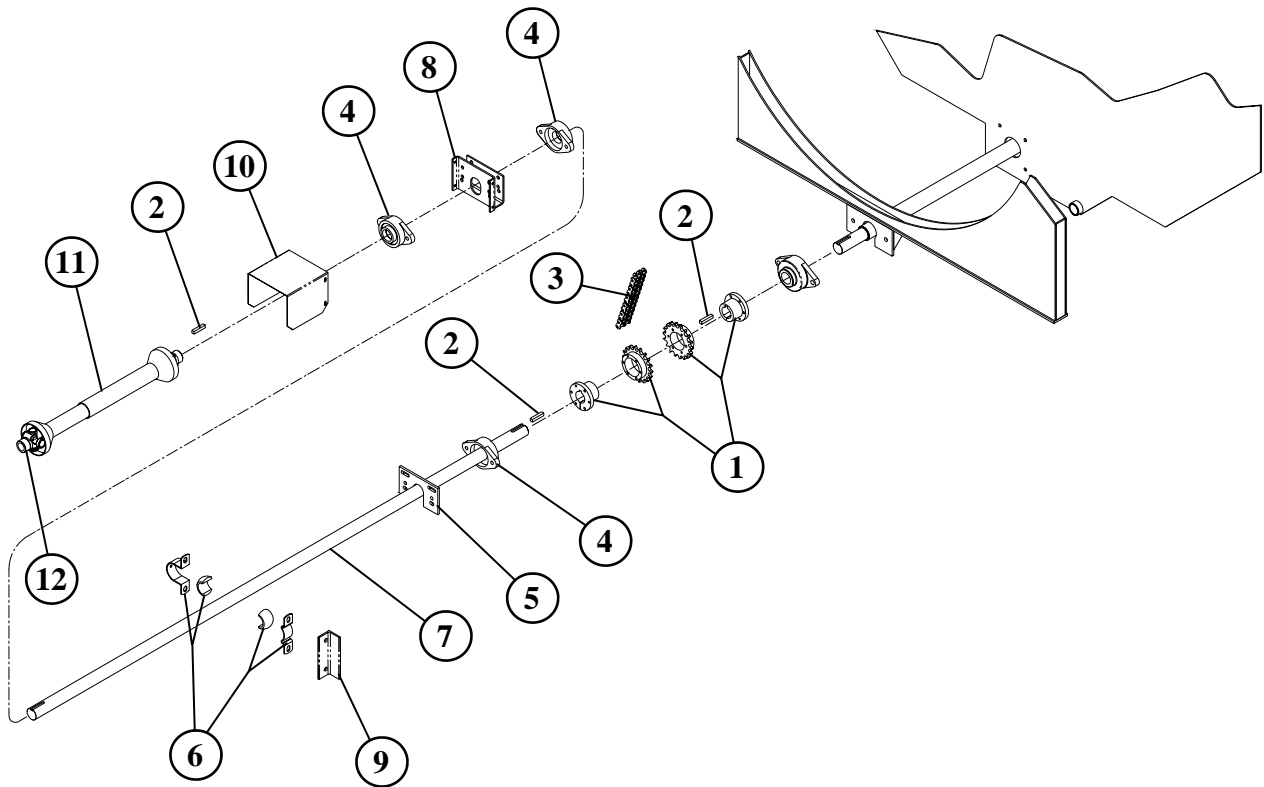

REF. NO	PART NO.	DESCRIPTION	QTY.
1	332612	60 B 20 x 1-3/4" CHAIN COUPLING SPRKT	2
2	185480	3/8" SQ. KEY x 2"	3
3	320720	#60-2 RC x 20 PITCHES COMP	1
4	340229	1-3/4" FX3W228U 2-BOLT FLANGE BEARING	3
5	183277	BEARING HANGER TRAILER UNIT	1
6	341028	1-3/4" PABCO BKP28T-TP W/BRG	1
7	150386	524 DRIVELINE-147"	1
8	850136	524 TRAILER BEARING PLATE WELDMENT	1
9	185299	CARRIER BEARING ANGLE	1
10	780601	PTO SHIELD ASSEMBLY	1
11	338030	W-2400 38399 DRIVESHAFT-540	1
12	338442	W-2400 019516 YOKE 1000 RPM	1

524 TRAILER DRIVESHAFT W-2400 (#383399)

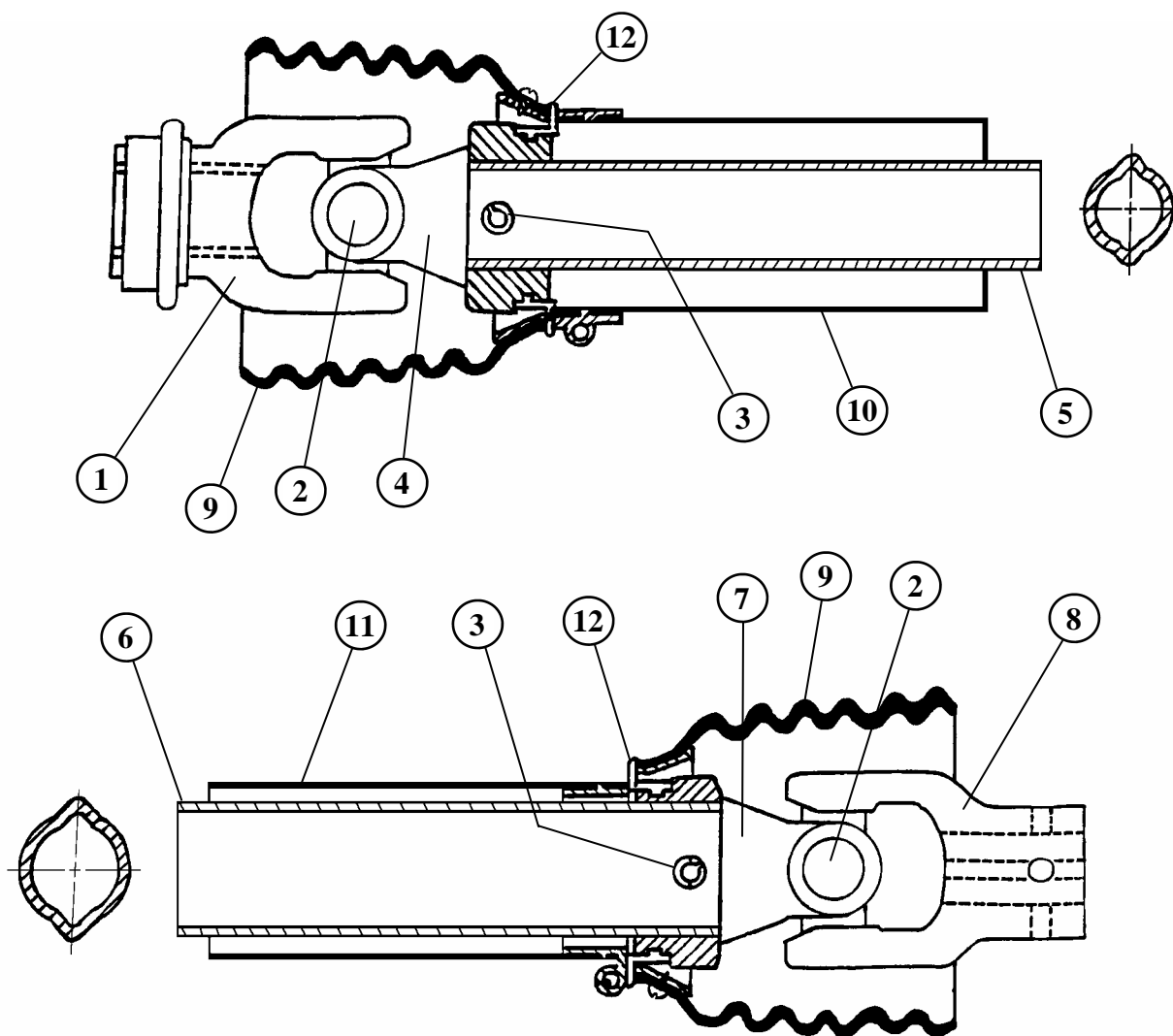

REF. NO	PART NO.	DESCRIPTION	QTY.
1		YOKE (TRACTOR END)	
A	338444	YOKE 540 RPM	1
B	338442	YOKE 1000 RPM	1
2	338443	CROSS KIT	2
3	338473	ROLL PIN METRIC #10	2
4	338450	INBOARD YOKE (TRACTOR END)	1
5	338474	INNER PROFILE (TRACTOR END)	1
6	338467	OUTER PROFILE (MIXER END).....	1
7	338452	INBOARD YOKE (MIXER END).....	1
8	338449	YOKE (MIXER END)	1
9	338486	SHIELD CONE 9-RIB	2
10	338487	OUTER SHIELD TUBE (TRACTOR END)	1
11	338488	INNER SHIELD TUBE (MIXER END)	1
12	338489	BEARING RING	2

524 TRAILER LOADCELL SCALE PARTS

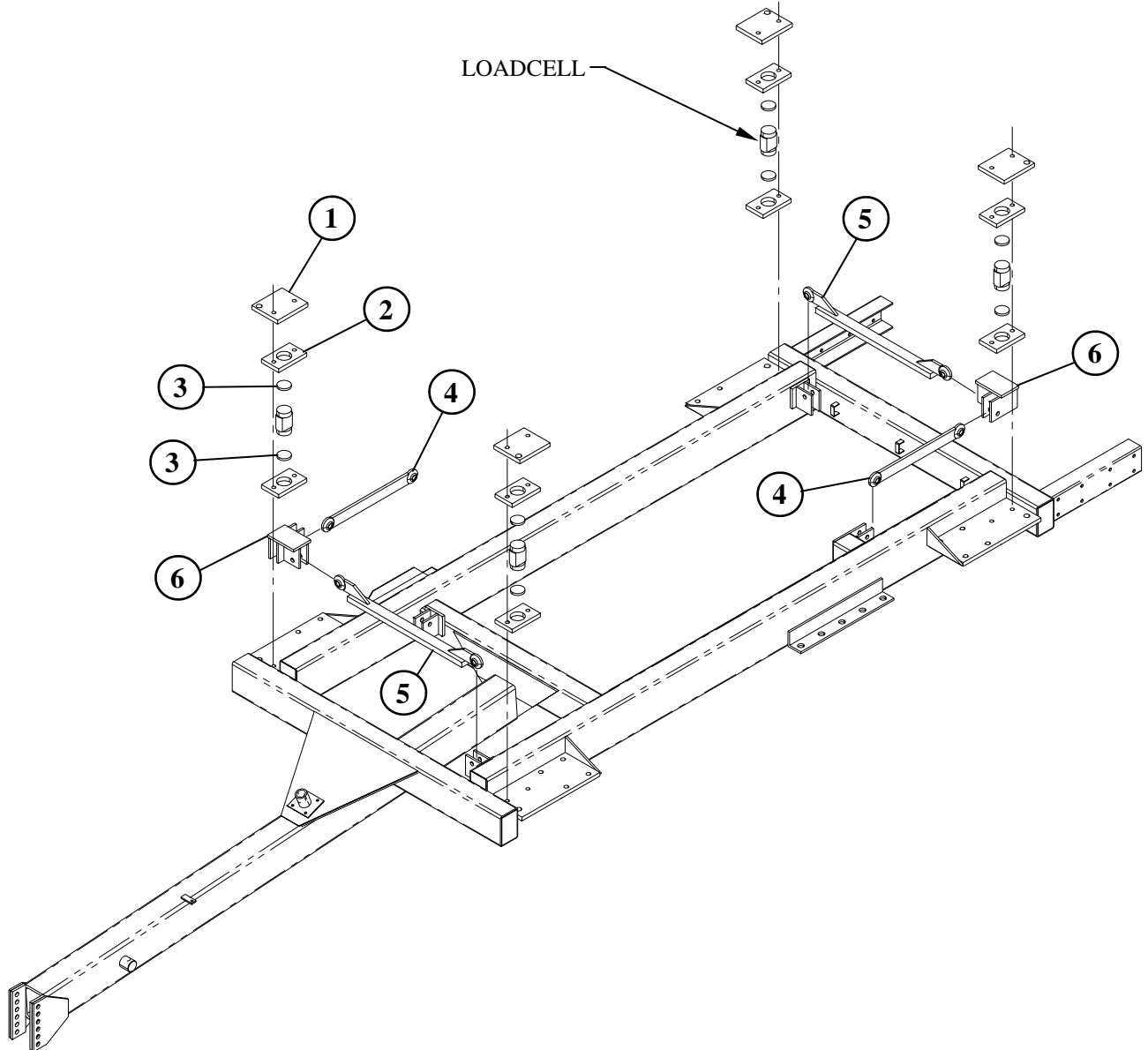

REF. NO	PART NO.	DESCRIPTION	QTY.
1	182881	SCALE MOUNT MIXER PAD.....	4
2	182915	LOADCELL CAGE PLATE	8
3	185997	3/8" SCALE PAD	8
4	870501	CHECK ROD WELDMENT	2
5	872245	OFFSET CHECK ROD WELDMENT	2
6	870519	MIXER SCALE CHECK WELDMENT	2

524 TRAILER WIEGH BAR ASSEMBLY

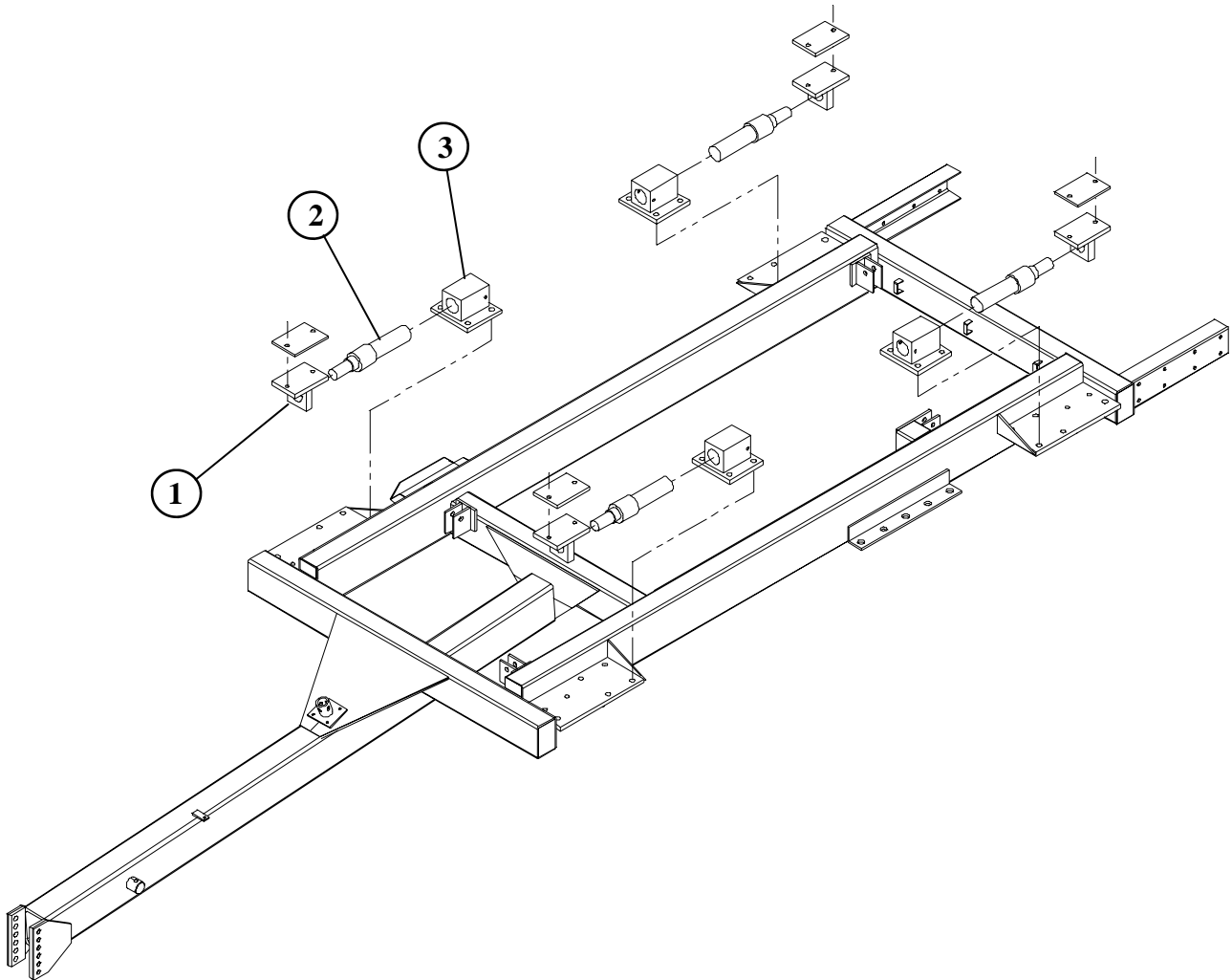

REF. NO	PART NO.	DESCRIPTION	QTY.
1	189294	WEIGH BAR MIXER PAD	4
2	872360	2-1/2" T-BAR WELDMENT	4
3	860055	2-1/2" BAR BLOCK WELDMENT	4

524 TRUCK SCALE FRAME ASSEMBLY

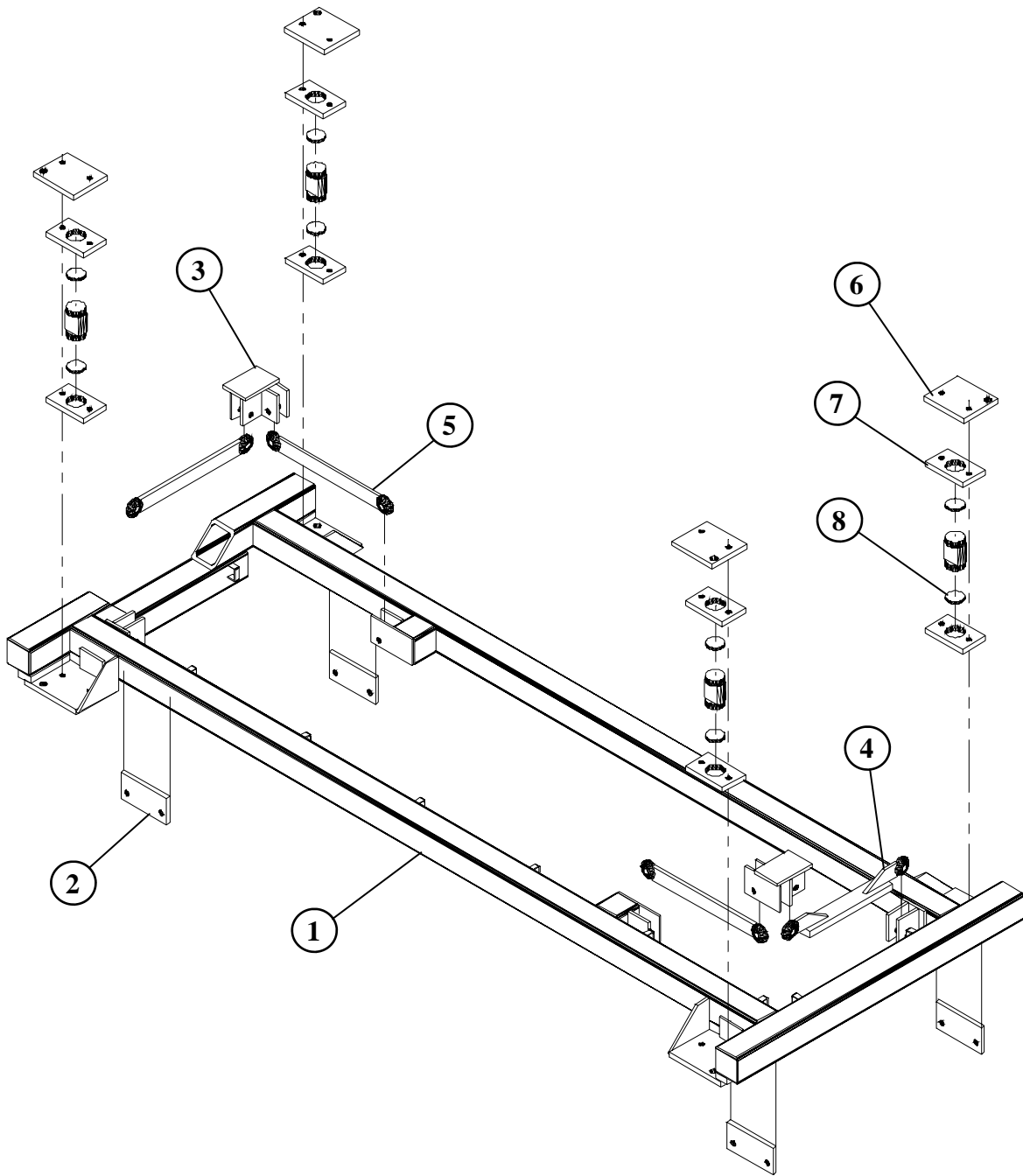

REF. NO	PART NO.	DESCRIPTION	QTY.
1	870527	SCALE FRAME WELDMENT.....	1
2	182998	TRUCK FRAME BRACKET.....	4
3	870519	MIXER CHECK WELDMENT	2
4	872053	OFFSET CHECK ROD.....	1
5	870501	CHECK ROD.....	3
6	182881	SCALE MOUNT MIXER PLATE.....	4
7	182915	LOADCELL CAGE PLATE	8
8	185997	SCALE PAD	8

524 TRUCK 2-1/2" WEIGH BAR SCALE FRAME ASSEMBLY

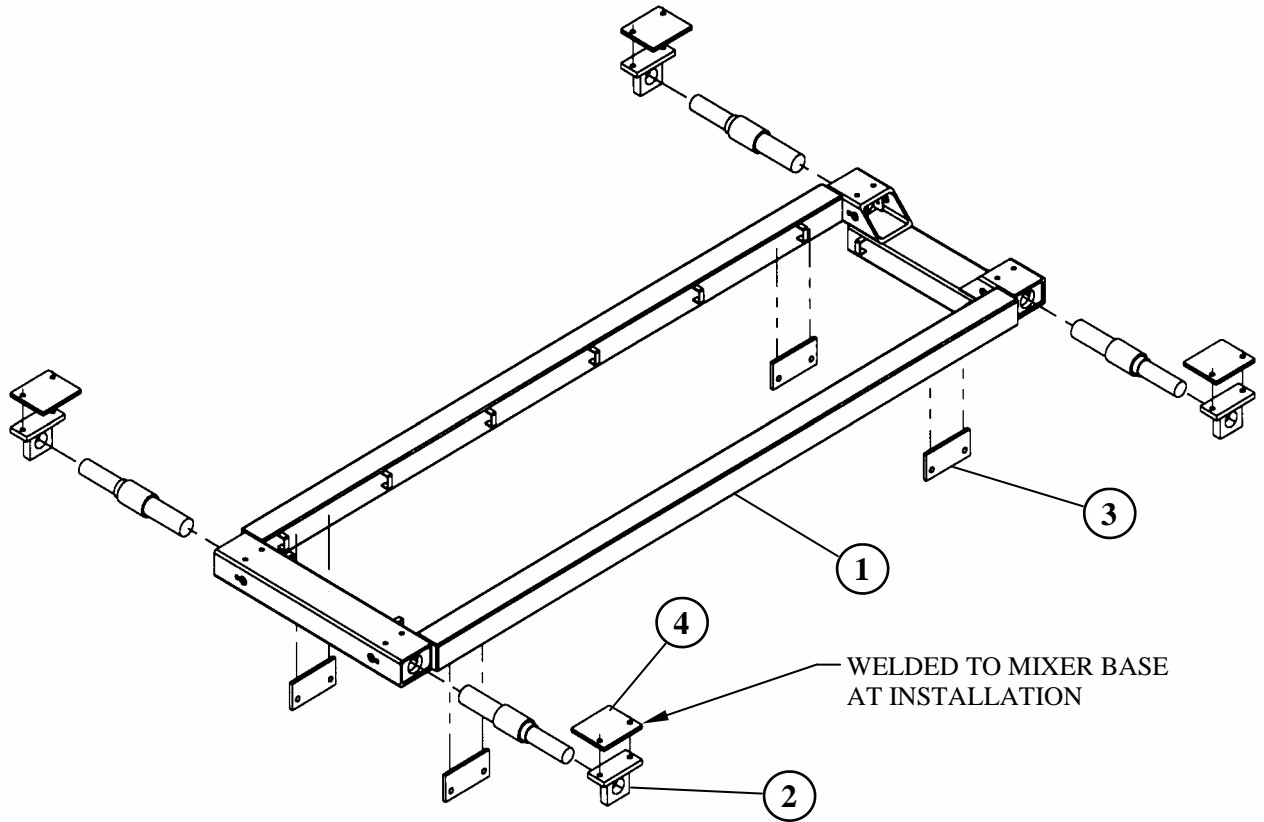

REF. NO	PART NO.	DESCRIPTION	QTY.
1	872163	524 TRUCK WEIGH BAR FRAME.....	1
2	872159	2-1/2" WEIGH BAR MOUNT WELDMENT	4
3	182998	TRUCK FRAME BRACKET	4
4	185609	BART MOUNT MIXER PAD.....	4

524 STATIONARY LOAD CELL SCALE FRAME ASSEMBLY

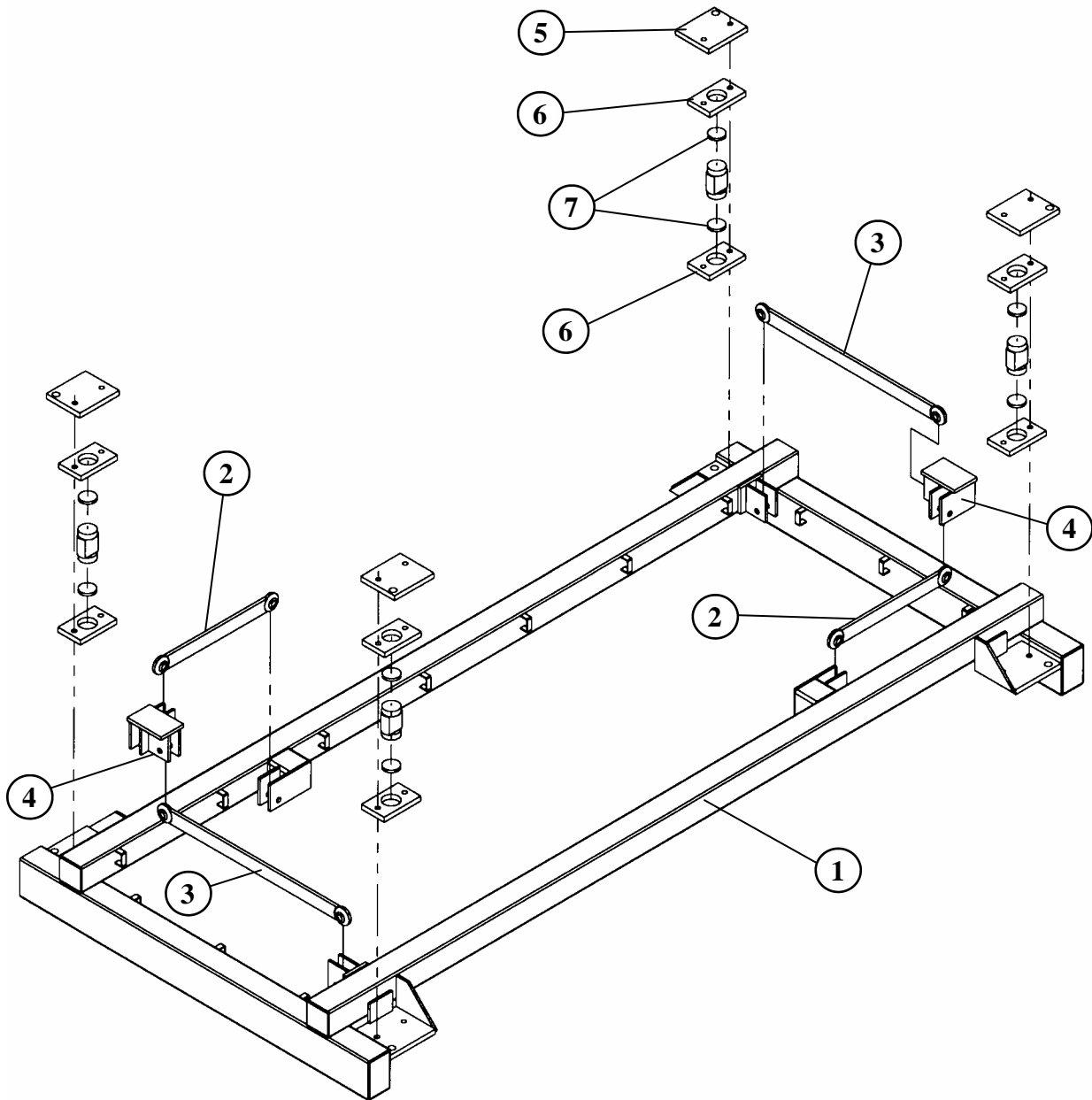

REF. NO	PART NO.	DESCRIPTION	QTY.
1	850150	524 STATIONARY SCALE FRAME WELDMENT	1
2	870501	SCALE CHECK ROD WELDMENT	2
3	871053	TRAILER CHECK ROD WELDMENT	2
4	870519	MIXER SCALE CHECK WELDMENT	2
5	182881	SCALE MIXER MOUNT PLATE.....	4
6	182915	LOADCELL CAGE PLATE	8
7	185997	SCALE PAD	8

524 TRAILER ASSEMBLY

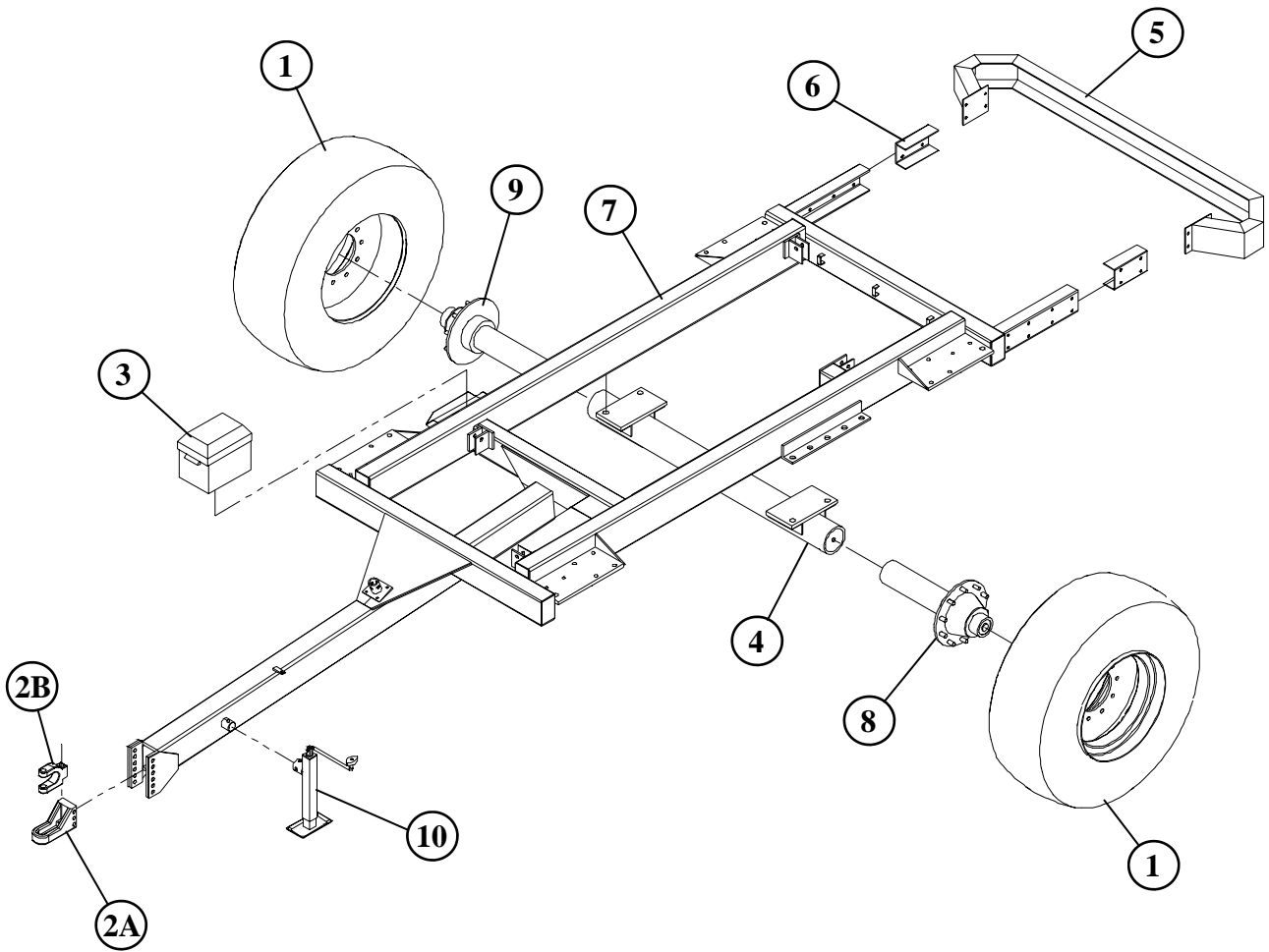

REF. NO	PART NO.	DESCRIPTION	QTY.
1	781241	18.5 x 22.5 MOUNTED TIRE ASSEMBLY	2
2	651024	PERFECT HITCH KIT (INCLUDES 2A & 2B).....	1
2A	374100	BASE HITCH BODY	1
2B	374101	CLEVIS INSERT	1
3	357400	BATTERY BOX WITH STRAP.....	1
4	870972	TRAILER AXLE WELDMENT	1
5	870733	TRAILER BUMPER WELDMENT.....	1
6	184598	TRAILER BUMPER EXTENSION.....	2
7	870931	TRAILER FRAME WELDMENT.....	1
8	750111	TRAILER HUB & SPINDLE - 10 BOLT LEFT HAND.....	1
9	840110	TRAILER HUB & SPINDLE - 10 BOLT RIGHT HAND	1
10A	374002	5000 LB. G&G JACK	1
10B	374001	9000 LB. DROP LEG JACK.....	1

**10-BOLT HUB & SPINLDE ASSEMBLY (20,000 LB.)
RIGHT HAND ASSY COMPLETE - #750110
LEFT HAND ASSY COMPLETE - #750111**

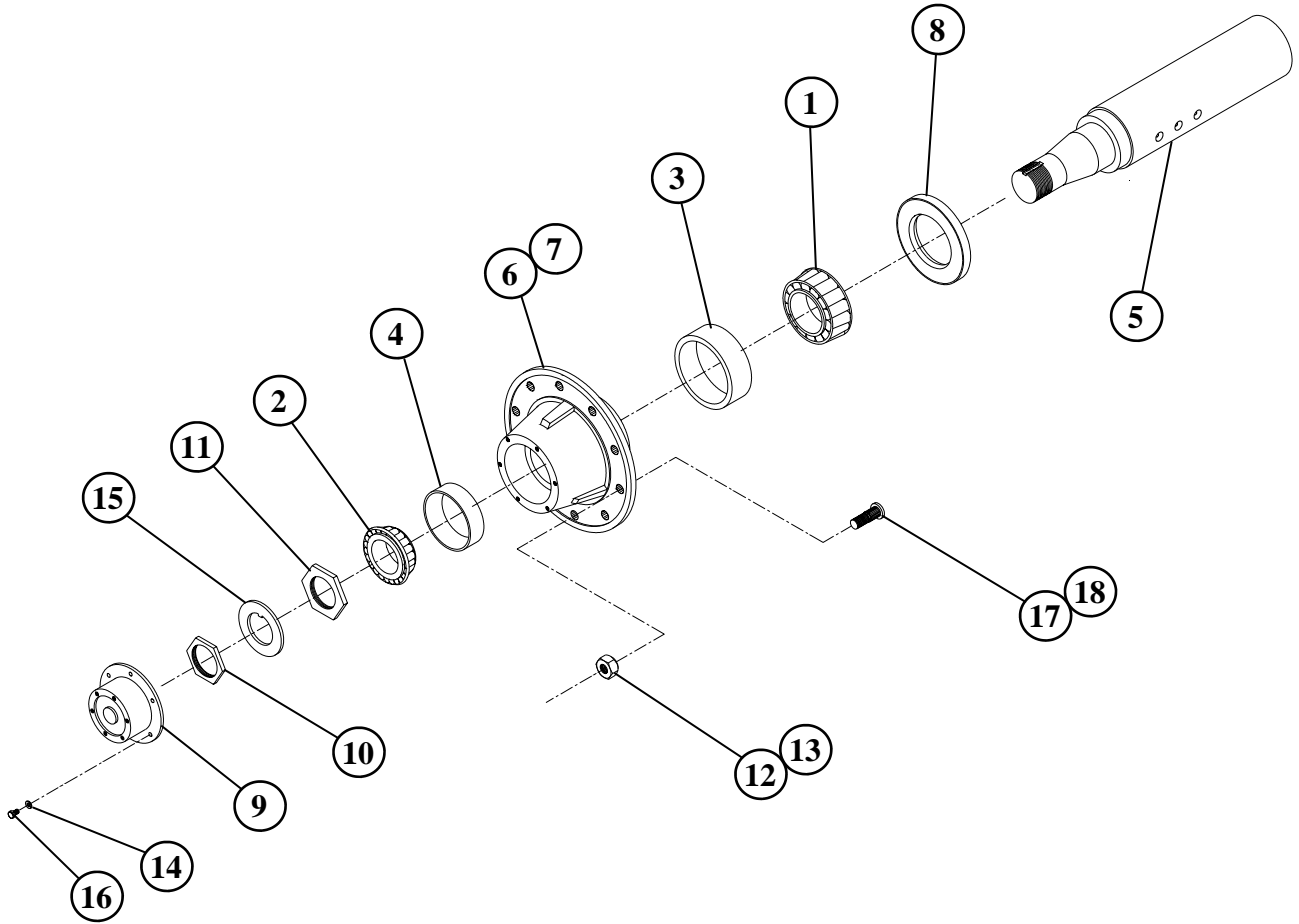

REF. NO	PART NO.	DESCRIPTION	QTY.
1	342213	BEARING, 3.543" BORE, TIMKEN #HM 218248.....	1
2	342214	BEARING, 2.625" BORE, TIMKEN #HM 212049.....	1
3	342215	BEARING CUP, 5.787" OD, TIMKEN #HM218210.....	1
4	342216	BEARING CUP, 4.813" OD, TIMKEN #212011	1
5	184614	SPINDLE, 4-9/16" x 25-1/2", 20,000 LB.....	1
6	372211	HUB, LEFT HAND, 10-BOLT, 20,000 LB.....	1
7	372212	HUB, RIGHT HAND, 10-BOLT, 20,000 LB	1
8	372304	SEAL, 4.563" x 6.001", #CR43771	1
9	372309	DUST CAP, 20,000 LB HUB	1
10	400033	OUTER NUT, 3/8" THICK x 2-5/8" ID.....	1
11	400034	INNER NUT, 3/8" THICK x 3-5/8" ID	1
12	400102	LUG NUT, RIGHT HAND, 3/4"	10
13	400103	LUG NUT, LEFT HAND, 3/4"	10
14	402005	LOCKWASHER, 5/16"	6
15	402904	WASHER, 1/4" THICK x 2-41/64" ID.....	1
16	405625	HHCS, 5/16" x 1/2"	6
17	407724	STUD BOLT, 3/4" x 2-9/16", RIGHT HAND	10
18	407725	STUD BOLT, 3/4" x 2-9/16", LEFT HAND.....	10

524 ROTO-HAY PROCESSOR ASSEMBLY (HYDRAULIC OPTION)

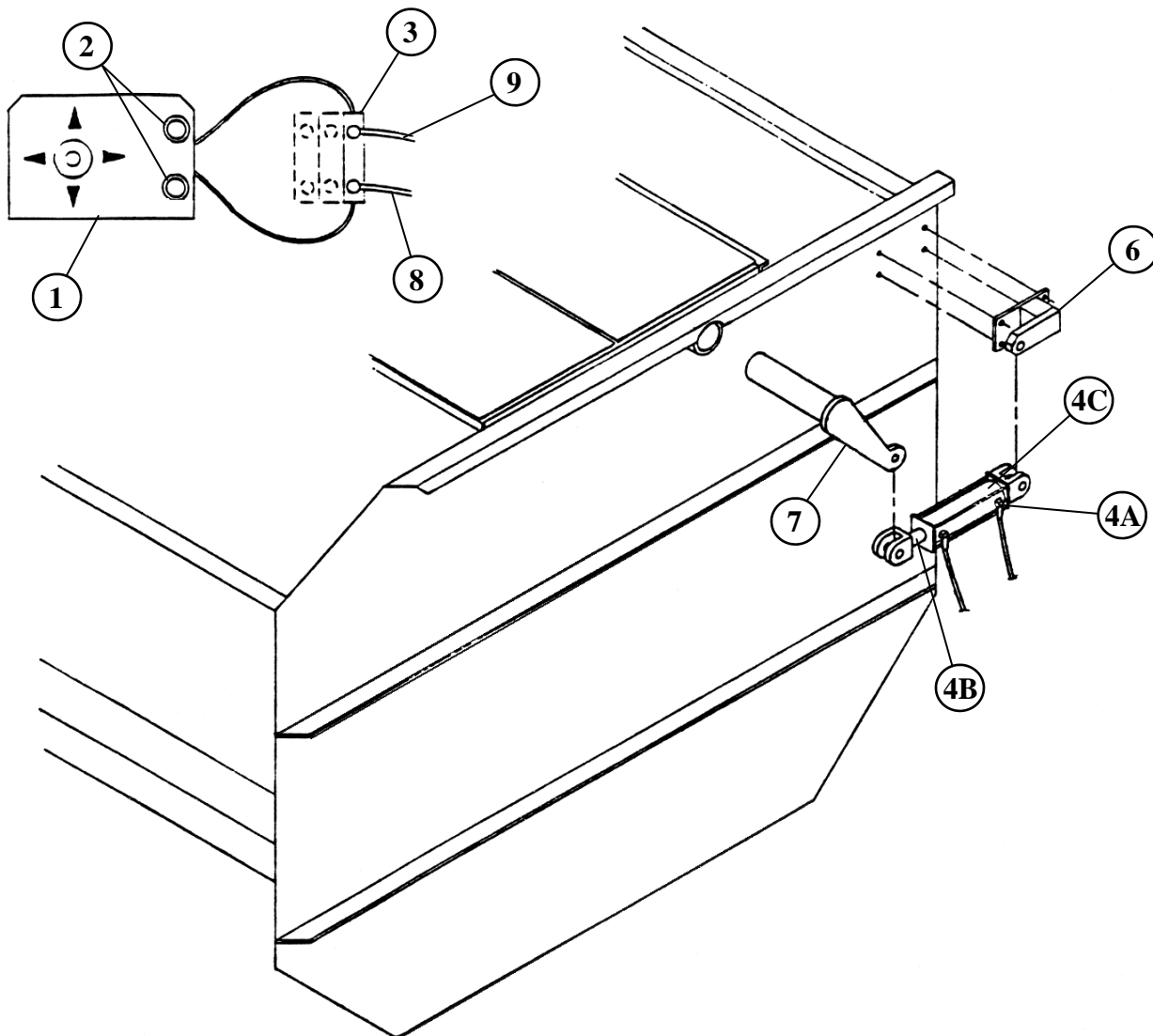

REF. NO	PART NO.	DESCRIPTION	QTY.
1	188226	FEEDER ELECTRIC CONTROL BRACKET.....	1
2	357702	PUSH BUTTON SWITCH 12V-2 POLE	1
3	780124	MV5 3rd VALVE ADD ON KIT	1
4	780109	CYLINDER ASSY, 2" x 8".....	1
4A	368007	RESTRICTOR FITTING, 3/8" MP x 3/8" FPSW 90°	2
4B	364954	CYLINDER ROD, 2" x 8" x 1-1/16" DIA	1
4C	364055	CYLINDER, 2" x 8" STROKE.....	1
4D	354400	REPAIR KIT, 2" HYDRAULIC CYLINDER.....	1
5	781055	TRUCK TO MIXER WIRE ASSEMBLY	1
6	850060	HAY PAN HYD. CYL. BRACKET WELDMENT.....	1
7	872357	HAY PAN HYDRAULIC ARM WELDMENT.....	1
8	781070	HYDRAULIC HOSE ASSY, 3/8" x 87" x 3/8" MP ENDS.....	1
9	781097	HYDRAULIC HOSE ASSY, 3/8" x 68" x 38" MP ENDS.....	1

524 ROTO-HAY PROCESSOR ASSEMBLY

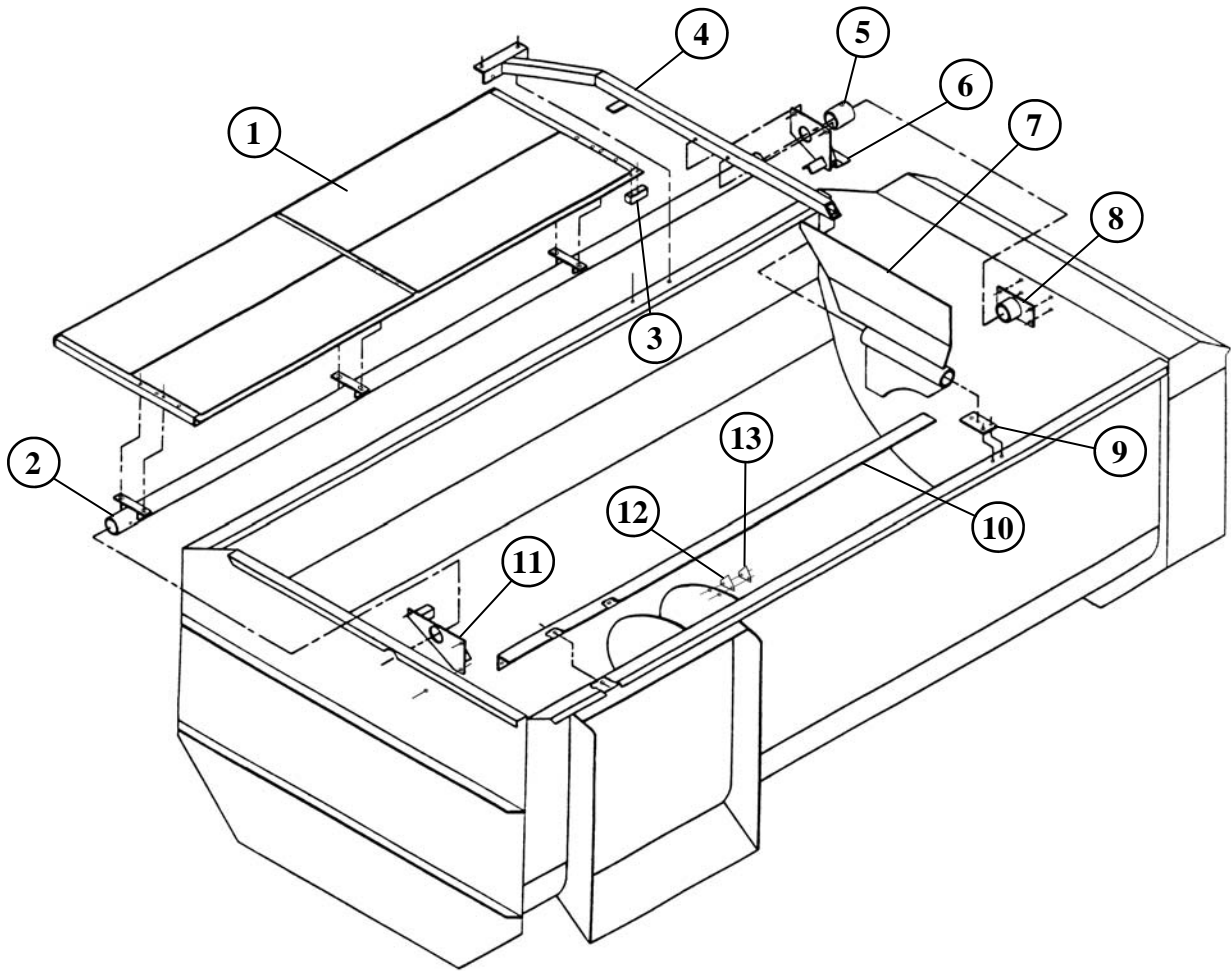

REF. NO	PART NO.	DESCRIPTION	QTY.
1	872351	524 HAY PAN WELDMENT	1
2	850144	524 HAY PAN TUBE WELDMENT	1
3	150198	BAFFLE PLUNGER	1
4	850301	524 CROSS BAR WELDMENT	1
5	189127	HAY TUBE SLEEVE RETAINER	1
6	872355	HAY PAN CENTER BEARING WELDMENT	1
7	850302	524 HAY PAN BAFFLE WELDMENT	1
8	872354	HAY PAN REAR BEARING WELDMENT	1
9	189128	CROSS BAR PLATE	1
10	150817	HAY PAN ANGLE.....	1
11	872353	HAY PAN FRONT BEARING WELDMENT	1
12	150223	KNIFE BACK-UP PLATE.....	43
13	385002	SICKLE SECTION, HARD SURFACED.....	43

524 ROTOR-HAY PROCESSOR (CABLE OPTION)

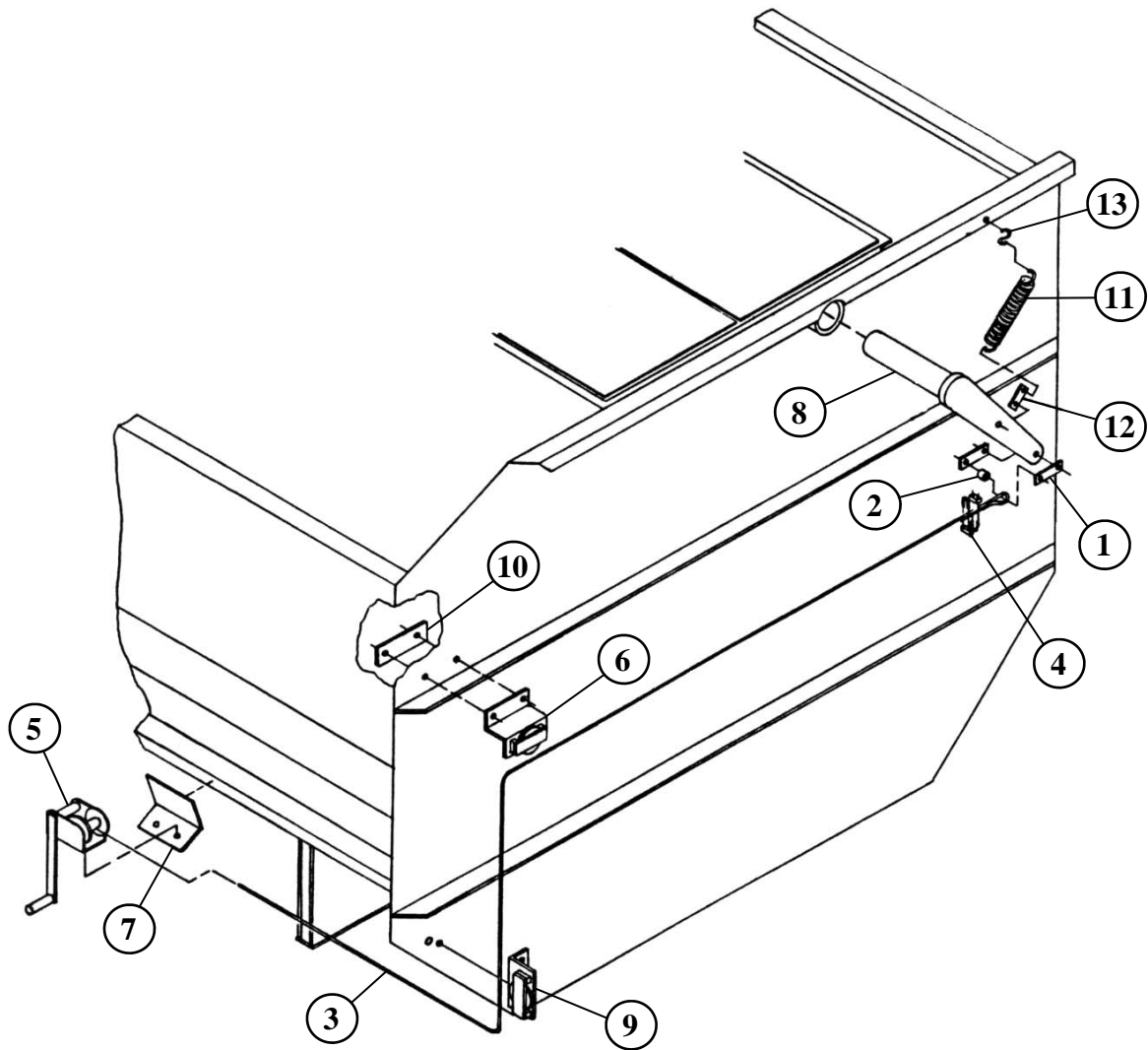

REF. NO	PART NO.	DESCRIPTION	QTY.
1	150188	CABLE BAR.....	2
2	150189	SLEEVE.....	1
3	150190	CABLE	1
4	412204	CABLE CLAMP, 1/4".....	2
5	412325	CABLE BRAKE WINCH, 1000LB.	1
6	850066	CABLE PULLEY BRACKET WELDMENT.....	1
7	150186	CABLE WINCH MOUNT PLATE	1
8	850090	HAY PAN CABLE ARM WELDMENT.....	1
9	850105	CORNER PULLEY BRACKET WELDMENT.....	1
10	150228	PULLEY BACKUP PLATE.....	1
11	410009	PULL SPRING, 1-1/4"OD x 14" x .177"	1
12	150391	SPRING PULL BAR.....	1
13	411805	S-HOOK, 5/16".....	1

524 BOTTOM AUGER FLOAT ASSEMBLY

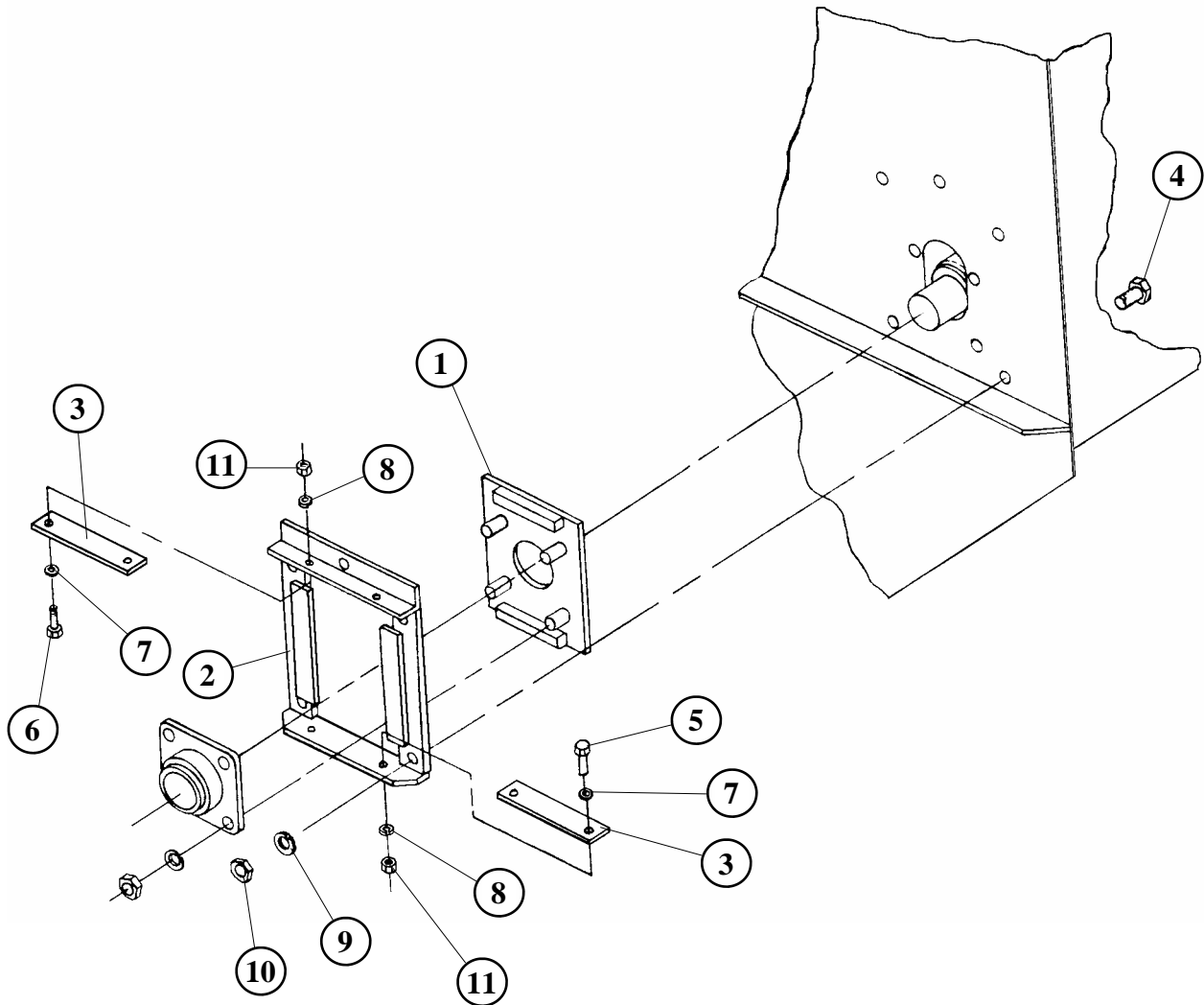

REF. NO	PART NO.	DESCRIPTION	QTY.
1	850153	BEARING SLIDE PLATE WELDMENT 2-7/16"	1
2	850154	BEARING SLIDE FRAME WELDMENT	1
3	150418	BEARING SLIDER PLASTIC	2
4	405752	HHCS 5/8" X 1 1/2"	5
5	405656	HHCS 3/8" X 1 3/4"	2
6	405655	HHCS 3/8" X 1 1/2"	2
7	402406	FLAT WASHER 3/8"	4
8	402006	LACK WASHER 3/8"	5
9	402010	LOCK WASHER 5/8"	4
10	400210	HEX NUT 5/8"	5
11	400206	HEX NUT 3/8"	4

524 FENDERS & MUD FLAPS

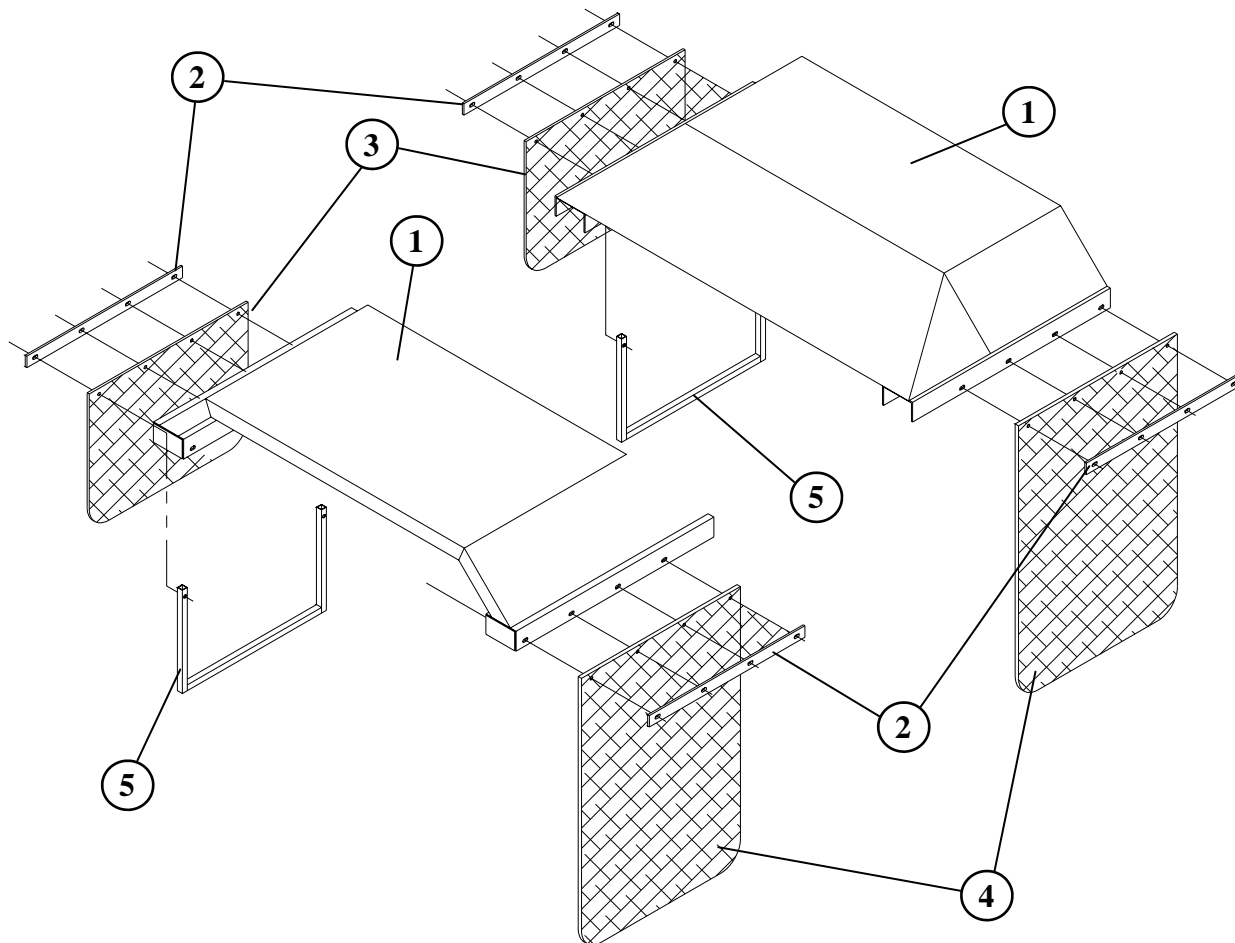

REF. NO	PART NO.	DESCRIPTION	QTY.
1	872108	FENDER WELDMENT.....	2
2	183087	MUD FLAP STRAP	4
3	370202	FRONT MUD STRAP	2
4	370200	REAR MUD STRAP.....	2
5	872120	MUD FLAP BRACKET WELDMENT	2

This Page intentionally left blank.