



620-16XD FEED MIXER

OPERATION AND PARTS MANUAL



**ROTO-MIX LLC
P.O. BOX 1724
2205 E. Wyatt Earp Blvd.
Dodge City, Kansas 67801
(620) 225-1142**

©ROTO-MIX 2006

SERIAL NUMBER _____

TABLE OF CONTENTS

	PAGE NO.
WARRANTY	3
SCALES WARRANTY & SERVICE POLICY	4
OPERATOR QUALIFICATIONS.....	5
SAFETY	6-15
OPERATION.....	16-19
MAINTENANCE	19-21
LOADING & UNLOADING	21-23
LUBRICATION	24-25
SPECIFICATIONS	26
PTO CHART	27
DIMENSIONS	28-31
REPAIR PARTS CONTENT PAGE	33

Revision Date	Changes
08/2023	Add Wiper Assembly number, pgs. 53-55



Limited Warranty Statement

ROTO-MIX LLC warrants to the original purchaser all products manufactured by it to be free from defects in material and workmanship under normal use and service.

ROTO-MIX's obligation under this warranty is limited to repairing or replacing, as the company may elect, free of charge and without charge for installation, at the place of business of a dealer or distributor authorized to handle the equipment covered by this warranty or at a ROTO-MIX facility, any parts that prove, in the company's judgment, to be defective in material or workmanship within one (1) year after delivery to the original purchaser, and still owned by the original purchaser. This warranty shall in no way make ROTO-MIX liable to anyone for personal injuries or damages, loss of time, or expense of any kind either direct or indirect resulting from part failure or defect. This warranty is subject to acts of God, fire and existing conditions of supply and demand, or production, or ability or inability to deliver, or for any other valid reason beyond the reasonable control of ROTO-MIX, to obtain materials, manufactured replacement parts, or make delivery thereof. No distributor, dealer, agent, or ROTO-MIX employee (other than the CEO or President in writing) is authorized to extend any other or further express or implied warranty or incur any additional obligation on ROTO-MIX's behalf in connection with the sale of this product.

If ROTO-MIX, or its duly authorized representative, shall find that such returned part or parts are defective and such defects, or defect, are included in and covered by said warranty, then such defective part or parts shall promptly be replaced without charge to the purchaser, F.O.B. the ROTO-MIX plant.

Product Registration - It is a condition of this warranty that the original purchaser must fill out the warranty card furnished by ROTO-MIX and that it be returned to ROTO-MIX within 10 days of purchase and be recorded in ROTO-MIX's owner file for this warranty to be valid. In the event an owner's card is not on file at the ROTO-MIX office, the warranty period will extend only from date equipment was picked up or shipped from the ROTO-MIX plant.

Maintenance - It is the customer's responsibility to maintain their equipment in accordance with the instructions provided in the Operator's Manual. ROTO-MIX recommends that you keep records and receipts; you may be asked to prove that maintenance instructions have been followed.

Operation - It is the customer's responsibility to operate the equipment only for the purpose for which it was designed and in accordance with all safety and operational recommendations contained in the Operators Manual. If a defect in materials or workmanship occurs, it is the customer's responsibility to cease operating the equipment until authorized repairs are made. **Damage, which occurs from continued operation, may not be covered by this warranty.**

What this Warranty Covers

This warranty covers failures caused by defects in materials or workmanship only.

This Warranty does not cover failures caused by:

- Improper operation
- Natural calamities
- Unauthorized modifications
- Unauthorized repairs
- Use of Non ROTO-MIX parts
- Neglected maintenance
- The use of PTO Shaft Adaptors
- Usage contrary to the intended purpose of the product

Go to the next page to continue the Warranty Statement.

Limited Warranty Statement continued

This Warranty does not cover replacement of Wear or Maintenance Items including, but not limited to.

- | | | | |
|--------------|----------|-------------|----------|
| - Lubricants | - Tires | - Chains | - Blades |
| - Filters | - Augers | - Idlers | - Belts |
| - Hoses | - Wipers | - Batteries | |

This Warranty does not cover:

- Pickup and delivery of the equipment
- Service Calls or Travel Time to and from sites
- Rental of replacement equipment during repair period
- Products that have been declared a total loss and subsequently salvaged
- Overtime labor charges
- ROTO-MIX is not responsible and will not be liable for damage caused to persons or property, commercial loss, loss of time or production, loss of use by reason of the installation or use of ROTO-MIX products or their mechanical failure.

Right to Make Changes

ROTO-MIX reserves the right to make any changes to a ROTO-MIX product at any time without incurring any obligation with respect to any product previously ordered, sold or shipped, with or without notice.

Parts Warranty

ROTO-MIX warrants replacement parts against defects in materials or workmanship for a period of 90 days or the remainder of the product warranty, whichever is longer. Remedy for defective replacement parts for units that are beyond the original product warranty, will be limited to replacement of the failed part. Failures that are due to damage, improper installation, lack of maintenance or improper operation will not be covered.

ROTO-MIX 2205 East Wyatt Earp Blvd., Dodge City, KS 67801 (620) 225-1142 Fax: (620) 225-6370

SCALES WARRANTY & SERVICE POLICY

DIGI-STAR SCALE SYSTEMS

Digi-Star, LLC warrants for a period of one year from date of installation, to correct by repair or replacement, at Digi-Star's option, any defect in material or workmanship in any part of this product. In the event of replacement, Digi-Star's sole obligation shall be to provide replacement products or parts. F.O.B. Digi-Star, LLC, W5527 Hwy 106, Fort Atkinson, WI 53538 USA.

WEIGH-TRONIX SCALE SYSTEMS

WEIGH-TRONIX warrants for a period of one year from date of installation, to correct by repair or replacement, at Weigh-Tronix's option, any defect in material or workmanship in any part of this product. In the event of replacement, Weigh-Tronix's sole obligation shall be to provide replacement products or parts. F.O.B. Avery Weigh-Tronix, 1000 Armstrong Drive, Fairmont, MN 56031-1439 USA.

OPERATOR QUALIFICATIONS

Operation Of this mixer/feeder shall be limited to competent and experienced persons. In addition, anyone who will operate or work around a mixer/feeder must use good common sense. In order to be qualified, he or she must also know and meet all other qualifications, such as:

1. Some regulations specify that no one under the age of sixteen (16) may operate power machinery. It is your responsibility to know what these regulations are in your area and/or situation.
2. Current OSHA regulations state in part: At the time of initial assignment and at least annually thereafter, the employer shall instruct **EVERY** employee in the safe operation and servicing of all equipment with which the employee is, or will be involved.
3. Unqualified persons are to **STAY OUT OF THE WORK AREA.**
4. A person who has not read and understood all operating and safety instructions is not qualified to operate the machinery.

FAILURE TO READ THIS MIXER/FEEDER MANUAL AND ITS SAFETY INSTRUCTIONS IS A MISUSE OF THE EQUIPMENT.



SAFETY

TAKE NOTE! THIS SAFETY ALERT SYMBOL FOUND THROUGHOUT THIS MANUAL IS USED TO CALL YOUR ATTENTION TO INSTRUCTIONS INVOLVING YOUR PERSONAL SAFETY AND THE SAFETY OF OTHERS. FAILURE TO FOLLOW THESE INSTRUCTIONS CAN RESULT IN INJURY OR DEATH.



THIS SYMBOL MEANS

-ATTENTION!

-BECOME ALERT!

-YOUR SAFETY IS INVOLVED!

SIGNAL WORDS: Note the use of the signal words **DANGER**, **WARNING**, and **CAUTION** with the safety messages. The appropriate signal word for each has been selected using the following guidelines:

DANGER: Indicates an imminently hazardous situation that, if not avoided, will result in serious injury or death. This signal word is to be limited to the most extreme situations typically for machine components which, for functional purposes, cannot be guarded.

WARNING: Indicates a potentially hazardous situation that, if not avoided, will result in serious injury or death, and includes hazards that are exposed when guards are removed. It may also be used to alert against unsafe practices.

CAUTION: Indicates a potentially hazardous situation that, if not avoided, may result in minor or moderate injury. It may also be used to alert against unsafe practices.

If you have questions not answered in this manual or require additional copies or the manual is damaged, please contact your dealer or ROTO-MIX, 2205 E. Wyatt Earp, Dodge City, Kansas, 67801. (Telephone) 620-225-1142 (Fax) 620-225-6370

SAFETY FIRST

REMEMBER: The careful operator is the best operator. Most accidents are caused by human error. Certain precautions must be observed to prevent the possibility of injury or death.



DO NOT ALLOW PERSONNEL OTHER THAN THE QUALIFIED OPERATOR NEAR THE MACHINE.



NEVER START MACHINE UNTIL ALL GUARDS AND SAFETY SHIELDS ARE IN PLACE.



DO NOT CLEAN, ADJUST OR LUBRICATE THE MACHINE WHILE IT IS IN MOTION.



BEFORE STARTING TRACTOR ENGINE, BE SURE PTO SHIELDS TURN FREELY.



LOOSE OR FLOPPY CLOTHING SHOULD NOT BE WORN BY THE OPERATOR.

OPERATING PRECAUTIONS & INSTRUCTIONS:

- A. Check to see that no obstructions are present in the mixer prior to start up.
- B. Before loading, run the mixer empty and check all operations.
- C. Do not overload the mixer, as the mixing efficiency may be reduced and unit damage may occur. (See loading instructions).
- D. Remove all moisture drain plugs if the mixer is going to set in the rain or snow.
- E. Be sure all shields are in place before operation.
- F. Use common sense when operating.



EQUIPMENT SAFETY GUIDELINES

Safety of the operator is one of the main concerns in designing and developing a new piece of equipment. Designers and manufactures build in as many safety features as possible. However, every year many accidents occur which could have been avoided by a few seconds of thought and a more careful approach to handling equipment. You, the operator, can avoid many accidents by observing the following precautions in this section. To avoid personal injury, study the following precautions and insist those working with you, or for you, follow them.

In order to provide a better view, certain photographs or illustrations in this manual may show an assembly with a safety shield removed. However, equipment should never be operated in this condition. Keep all shields in place. If shield removal becomes necessary for repairs, replace the shield prior to use.

Replace any CAUTION, WARNING, DANGER or instruction safety decal that is not readable or is missing. Location of such decals are indicated in this manual.

Do not attempt to operate this equipment under the influence of drugs or alcohol.

Review the safety instructions with all users annually.

This equipment is dangerous to children and persons unfamiliar with its operation. The operator should be a responsible adult familiar with farm machinery and trained in this equipment's operations. Do not allow persons to operate or assemble this unit until they have read this manual and have developed a thorough understanding of the safety precautions and of how it works.

To prevent injury or death, use a tractor equipped with a Roll Over Protective System (ROPS). Do not paint over, remove or deface any safety signs or warning decals on your equipment. Observe all safety signs and practice the instructions on them.



Never exceed the limits of a piece of machinery, in its ability to do a job, or to do so safely, is in question - **DON'T TRY IT.**

LIGHTING AND MARKING

It is the responsibility of the customer to know the lighting and marking requirements of the local highway authorities and to install and maintain the equipment to provide compliance with the regulations. Add extra lights when transporting at night or during periods of limited visibility.



KEEP ALL SHIELDS IN PLACE

Do not operate mixer/feeder without safety shields in place.

Rotating parts can crush or dismember causing personal injury or death.

Disconnect PTO driveline before removing shields for adjustment or service.



OPERATE MIXER/FEEDER SAFELY

Rotating parts can entangle or strike people, resulting in personal injury or death.

Never enter a mixer/feeder while in operation.

Operate the mixer/feeder from the operator's seat only.

Do not exceed load capacity of the mixer/feeder. (See loading instructions).

Reduce speed when turning or traveling on rough terrain.

Avoid traveling over loose fill, rocks, ditches or holes.

Keep transmissions in gear when traveling downhill.



KEEP RIDERS OFF MIXER/FEEDER

Keep riders off.

Riders are subject to injury such as being struck by foreign objects and being thrown off. Riders also obstruct the operator's view resulting in the machine being operated in an unsafe manner.





STAY CLEAR OF ROTATING DRIVELINES

Entanglement in rotating driveline can cause serious injury or death.

Keep tractor master shield and driveline shields in place at all times. Make sure rotating shields turn freely.

Wear close fitting clothing. Stop the engine and be sure PTO driveline is stopped before making adjustments, connections, or cleaning out PTO driven equipment .



PREVENT BATTERY EXPLOSIONS

Keep sparks, lighted matches, and open flame away from the top of battery. Battery gas can explode.

Never check battery charge by placing a metal object across the posts. Use a volt-meter or hydrometer.

Do not charge a frozen battery; it may explode. Warm battery to 16C (60F)



AVOID HIGH-PRESSURE FLUIDS

Escaping fluid under pressure can penetrate the skin causing serious injury or death.

Avoid the hazard relieving pressure before disconnecting hydraulic or other lines. Tighten all connections before applying pressure.

Search for leaks with a piece of cardboard. Protect hands and body from high pressure fluids.

If an accident occurs, see a doctor immediately. Any fluid injected into the skin must be surgically removed within a few hours or gangrene may result. Doctors unfamiliar with this type of injury should reference a knowledgeable medical source.





PREPARING TRACTOR FOR TRAILER MIXER

POSITIONING DRAWBAR

IMPORTANT: Drive components can be damaged from excessive speed. Under no circumstances should a feed mixer equipped with 540 RPM be operated by a tractor with 1000 RPM PTO.

Feed mixers are available with either 540 or 1000 RPM driveline. Match tractor PTO with the feed mixer driveline.

IMPORTANT: To prevent driveline damage, adjust tractor drawbar to recommended setting. Disengage tractor PTO before turning.

Remove clevis if equipped when there is a clevis used on the mixer tongue.

Adjust drawbar length:

PTO SPEED	DIMENSION (A)
540 RPM	14" (256 mm)
1000 RPM (1-3/8" - 21 SPLINE)	16" (406 mm)
1000 RPM 91-3/4" - 20 SPLINE	20" (508 mm)

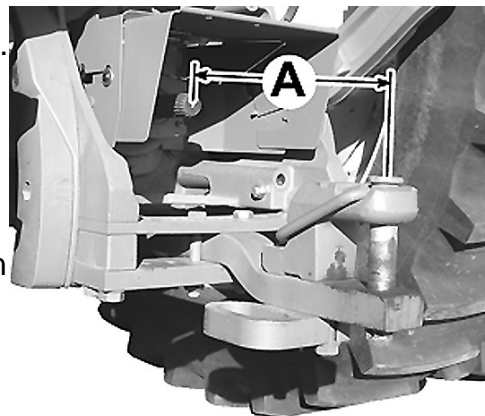

ADJUST TRAILER HITCH CLEVIS

Mixer should be approximately level when attached to tractor.

Adjust clevis by changing hole location on tongue.

Hitch Pin Size — 1" x 7"

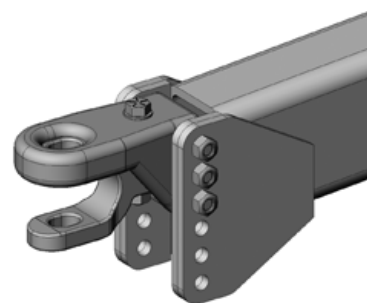

SAFETY SIGNS

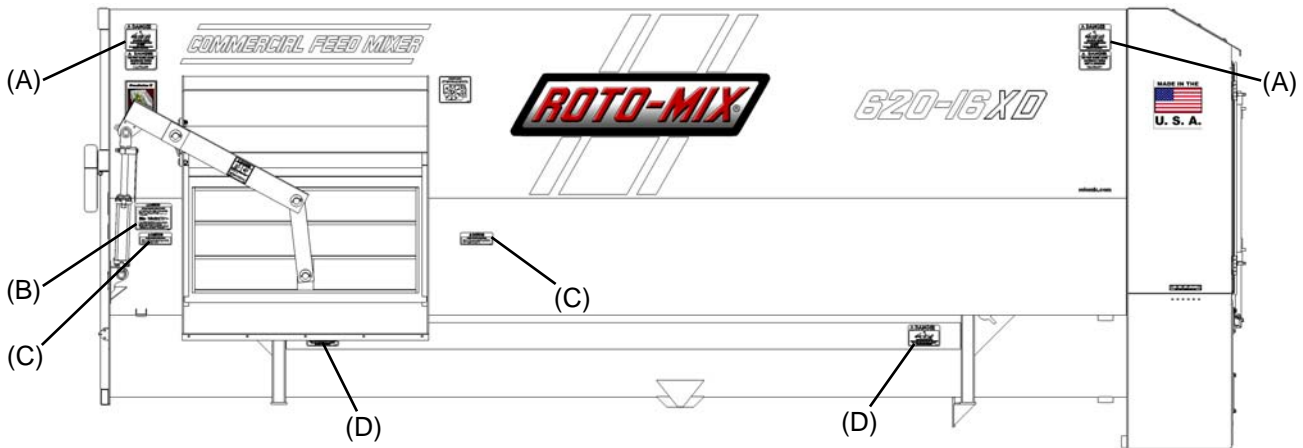

(A) #440035



(B) #440819

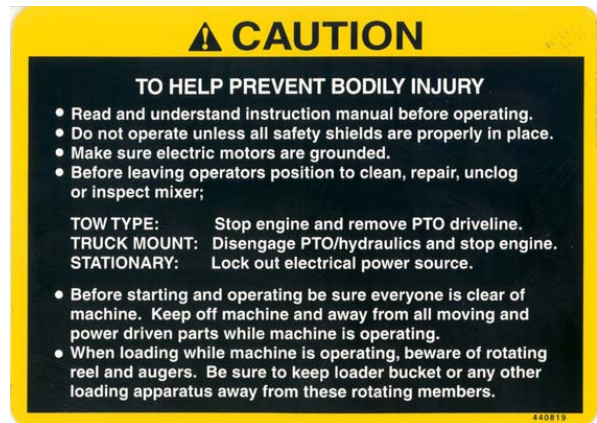

(C) #440818



(D) #440826



SAFETY SIGNS

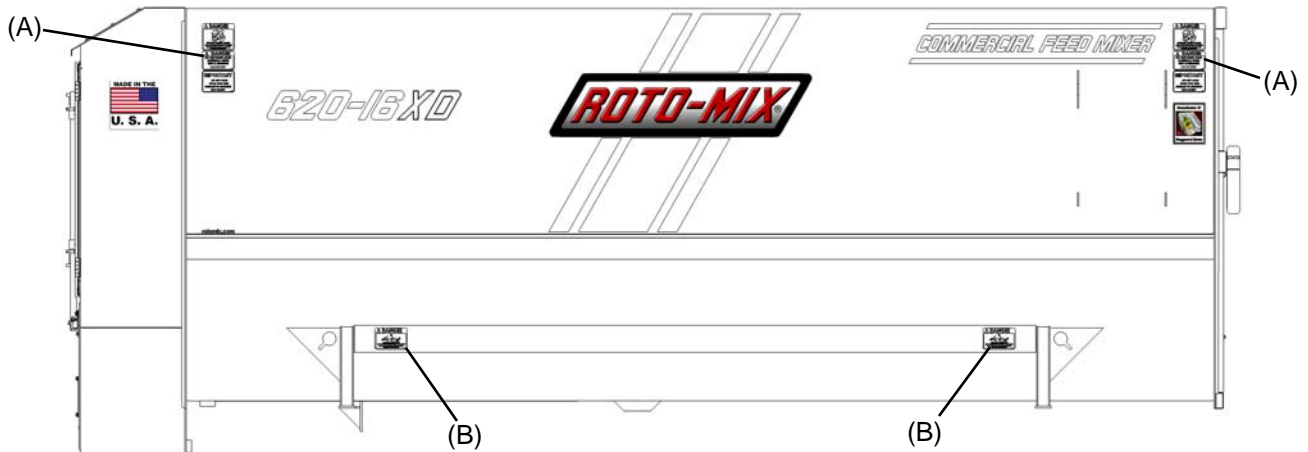

(A) #440034



(B) #440826

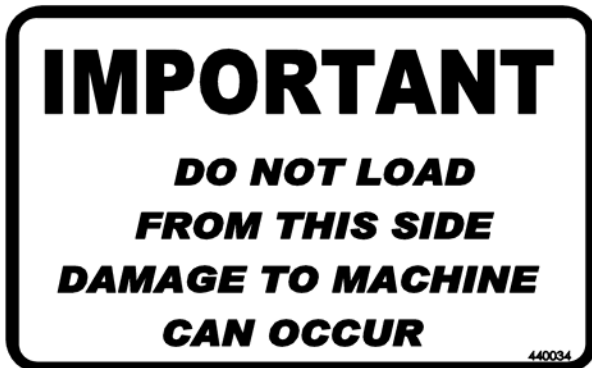

SAFETY SIGNS

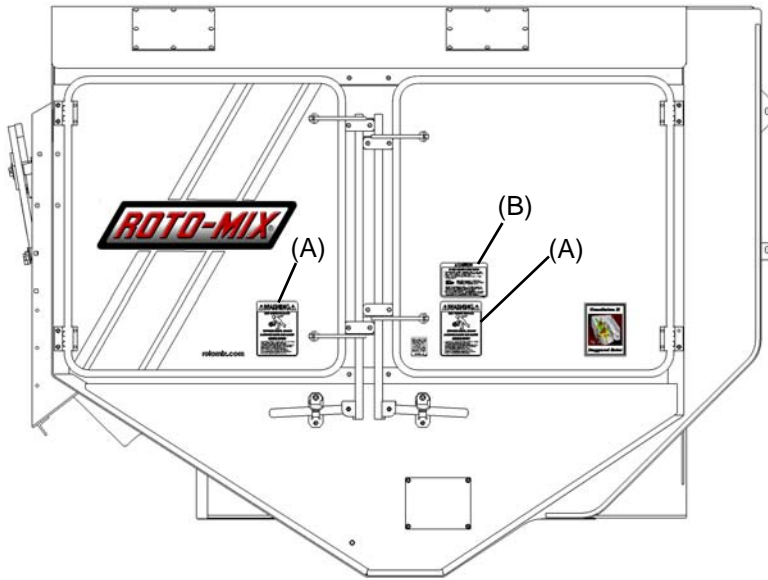

BACK OF MIXER

(C) #440801

IMPORTANT

ALWAYS REDUCE ENGINE SPEED TO IDLE BEFORE ENGAGING AND DISENGAGING PTO. DISENGAGE TRACTOR PTO BEFORE TURNING.

440801

(A) #440822

! WARNING !

KEEP SHIELDS IN PLACE

EXPOSED BELTS, CHAINS & MOVING PARTS CAN CAUSE SEVERE INJURY

- READ AND UNDERSTAND INSTRUCTION MANUAL BEFORE OPERATING.
- KEEP ALL SAFETY SHIELDS AND DEVICES IN PLACE.
- MAKE CERTAIN EVERYONE IS CLEAR BEFORE OPERATING MACHINE.
- KEEP HANDS, FEET AND CLOTHING AWAY FROM MOVING PARTS.
- SHUT OFF POWER TO ADJUST, SERVICE OR CLEAN.
- MAKE SURE MACHINE IS SECURED BEFORE OPERATING.
- DISCONNECT POWER BEFORE RESETTING MOTOR OVERLOAD.
- MAKE CERTAIN ELECTRIC MOTORS ARE GROUNDED.

(B) #440819

! CAUTION

TO HELP PREVENT BODILY INJURY

- Read and understand instruction manual before operating.
- Do not operate unless all safety shields are properly in place.
- Make sure electric motors are grounded.
- Before leaving operators position to clean, repair, unclog or inspect mixer;

TOW TYPE: Stop engine and remove PTO driveline.
TRUCK MOUNT: Disengage PTO/hydraulics and stop engine.
STATIONARY: Lock out electrical power source.

- Before starting and operating be sure everyone is clear of machine. Keep off machine and away from all moving and power driven parts while machine is operating.
- When loading while machine is operating, beware of rotating reel and augers. Be sure to keep loader bucket or any other loading apparatus away from these rotating members.

440819

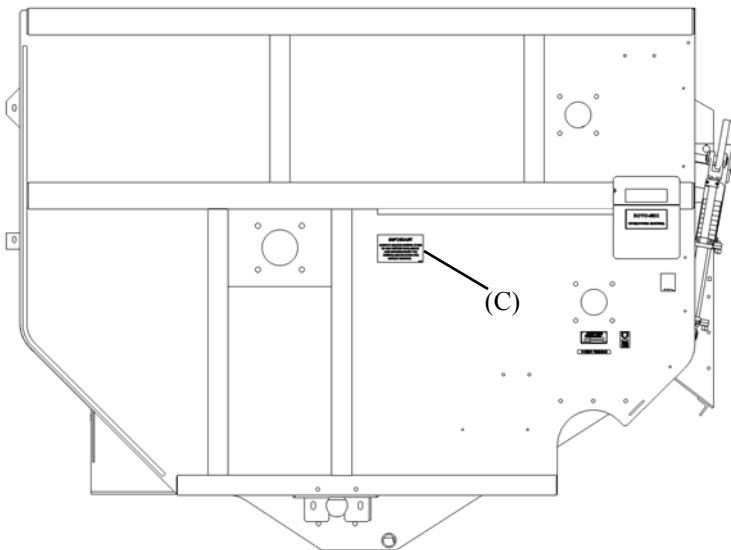

FRONT OF MIXER



PRACTICE FIRE PREVENTION

Keep fire extinguishers accessible at all times. Use the extinguisher recommended for the material being processed. It should be rated safe for use on electrical fires.

Never smoke close to combustible material.

Clean the area before welding or other activities which may make sparks.

Keep all components that generate excessive heat clear of oil and other combustible materials.



SAFETY DECAL CARE

Keep safety decals and signs clean and legible at all times.

Replace safety decals and signs that are missing or have become illegible.

Replaced parts that displayed a safety sign should also display the current sign.

Safety decals or signs are available from your dealer or the ROTO-MIX manufacturing plant.

How to Install Safety Decals:

Be sure that the installation area is clean and dry.

Decide on the exact position before you remove the backing paper.

Remove the smallest portion of the split backing paper.

Align the decal over the specified area and carefully press the small portion with the exposed sticky backing in place.

Slowly peel back the remaining paper and carefully smooth the remaining portion of the decal in place.

Small air pockets can be pierced with a pin and smoothed out using the piece of decal backing paper.



REMEMBER

Your best assurance against accidents is a careful and responsible operator. If there is any portion of this manual or function you do not understand, contact your dealer or the ROTO-MIX plant.

BEFORE OPERATION:

Carefully study and understand this manual.

Do not wear loose-fitting clothing which may catch in moving parts.

Always wear protective clothing and substantial shoes.

Keep wheel lug nuts or bolts tightened to specified torque.

Assure that agricultural implement tires are inflated evenly.

Give the unit a visual inspection for any loose bolts, worn parts or cracked welds, and make necessary repairs. Follow the maintenance safety instructions included in this manual.

Be sure that there are no tools lying on or in the mixer/feeder.

Do not use the unit until you are sure that the area is clear, especially children and animals.

Because it is possible that this mixer/feeder may be used in dry areas or the presence of combustibles, special precautions should be taken to prevent fires and fire fighting equipment should be readily available.

Don't hurry the learning process or take the unit for granted. Ease into it and become familiar with your new mixer/feeder.

Practice operation of your mixer/feeder and its attachments. Completely familiarize yourself and other operators with its operation before using.

Securely attach to towing unit. Use a high strength, appropriately sized hitch pin with a mechanical retainer.

Do not allow anyone to stand between the tongue or hitch and the towing vehicle when backing up to the mixer/feeder.



DURING OPERATION:

Beware of bystanders, **particularly children!** Always look around to make sure that it is safe to start the engine of the towing vehicle or move the unit. This is particularly important with higher noise levels and quiet cabs, as you may not hear people shouting.

NO PASSENGERS ALLOWED - Do not carry passengers anywhere on, or in, the tractor or equipment, except as required for operation.

Keep hands and clothing clear of moving parts.

Do not clean, lubricate or adjust your mixer/feeder while it is moving.

Be especially observant of the operating area and terrain - watch for holes, rocks or other hidden hazards. Always inspect the area prior to operation.

Do not operate near the edge of drop-offs or banks.

Do not operate on steep slopes as overturn may result.

Operate up and down (not across) intermediate slopes. Avoid sudden starts and stops.

Pick the levellest possible route when transporting across fields. Avoid the edges of ditches or gullies and steep hillsides.

Be extra careful when working on inclines.

Periodically clear the equipment of brush, twigs or other materials to prevent buildup of dry combustible materials.

Maneuver the tractor or towing vehicle at safe speeds.

Avoid overhead wires or other obstacles. Contact with overhead lines could cause serious injury or death.

Avoid loose fill, rocks and holes; they can be dangerous for equipment operation or movement. Allow for unit length when making turns.

Do not walk or work under raised components or attachments unless securely positioned and blocked.

Keep all bystanders, pets and livestock clear of the work area.

Operate the towing vehicle from the operator's seat only.

Never stand alongside of the unit with engine running. Never attempt to start engine and/or operate machine while standing alongside of unit.



DURING OPERATION (CONT.)

Never leave running mixer/feeder unattended.

As a precaution, always recheck the hardware on mixer/feeder following every 100 hours of operation. Correct all problems. Follow the maintenance safety procedures.



FOLLOWING OPERATION:

Following operation, or when unhitching, stop the tractor or towing vehicle, set the brakes, disengage the PTO and all power drives, shut off the engine and remove the ignition keys.

Store the unit in an area away from human activity.

Do not park equipment where it will be exposed to livestock for long periods of time. Damage and livestock injury could result.

Do not permit children to play on or around the stored unit.

Make sure parked machine is on a hard, level surface and engage all safety devices.



Wheel chocks may be needed to prevent unit from rolling.

HIGHWAY AND TRANSPORT OPERATIONS:

Adopt safe driving practices:

Keep the brake pedals latched together at all times. **Never use independent braking with machine in tow as loss of control and/or upset of unit can result.**

Always drive at a safe speed relative to local conditions and ensure that your speed is low enough for an emergency stop to be safe and secure. Keep speed to a minimum.

Reduce speed prior to turns to avoid the risk of overturning.

Avoid sudden uphill turns on steep slopes.

Always keep the tractor or towing vehicle in gear to provide engine braking when going downhill. Do not coast.

Do not drink and drive.



HIGHWAY AND TRANSPORT OPERATIONS (CONT.):

Comply with state and local laws governing highway safety and movement of farm machinery on public roads.

Use approved accessory lighting flags and necessary warning devices to protect operators of other vehicles on the highway during daylight and nighttime transport.

The use of flashing amber lights is acceptable in most localities. However, some localities prohibit their use. Local laws should be checked for all highway lighting and marking requirements.

When driving the tractor and mixer/feeder on the road or highway under 20 MPH (40 KPH) at night or during the day, use flashing amber warning lights and a slow moving vehicle (SMV) identification emblem.

Plan your route to avoid heavy traffic.

Be a safe courteous driver. Always yield to oncoming traffic in all situations, including narrow bridges, intersections, etc.

Be observant of bridge loading ratings. Do not cross bridges rated lower than the gross weight at which you are operating.

Watch for obstructions overhead and to the side while transporting.

Always operate mixer/feeder in a position to provide maximum visibility at all times. Make allowances for increased length and weight of the mixer/feeder when making turns, stopping the unit, etc.



PERFORMING MAINTENANCE:

Good maintenance is your responsibility. Poor maintenance is an invitation to trouble.

Make sure there is plenty of ventilation. Never operate the engine of the towing vehicle in a closed building. The exhaust fumes may cause asphyxiation.

Before working on the mixer/feeder, stop the towing vehicle, set the brakes, disengage the PTO and all power drives, shut off the engine and remove the ignition keys.

Be certain all moving parts on attachments have come to a complete stop before attempting to perform maintenance.

Always use a safety support and block the wheels. Never use a jack to support the machine.



PERFORMING MAINTENANCE (CONT.):

Always use the proper tools or equipment for the job at hand.

Use extreme caution when making adjustments.

Never use your hands to locate hydraulic leaks on attachments. Use a small piece of cardboard or wood. Hydraulic fluid escaping under pressure can penetrate the skin.

When disconnecting hydraulic lines, shut off hydraulic supply and relieve all hydraulic pressure.

Openings in the skin and minor cuts are susceptible to infection from hydraulic fluid. If injured by escaping hydraulic fluid, see a doctor at once. Gangrene can result. Without immediate treatment, serious infection and reactions can occur.

Replace all shields and guards after servicing and before moving.

After servicing, be sure all tools, parts and service equipment are removed.

Do not allow grease or oil to build up on any step or platform.

Never replace hex bolts with less than grade five (5) bolts unless otherwise specified.

Where replacement parts are necessary for periodic maintenance and servicing, genuine factory replacement parts must be used to restore your equipment to original specifications. ROTO-MIX will not claim responsibility for use of unapproved parts and/or accessories and other damages as a result of their use.

If equipment has been altered in any way from original design, ROTO-MIX does not accept any liability for injury or warranty.

A fire extinguisher and first aid kit should be kept readily accessible while performing maintenance on this mixer/feeder.

READ THE FOLLOWING BEFORE WELDING ON THIS MIXER/FEEDER

When welding on your mixer/feeder, do not allow the current to flow through the ball bearings or the roller chains. Ground directly to the item being welded.

Always disconnect the scale instrumentation from the weigh bars or load cells and the power source. Be sure the current does not pass through weigh bars or load cells or scale indicator. The alternator should always be disconnected if the mixer/feeder is not disconnected from the towing vehicle.

CHAIN TENSION

All the single roller chain should be tightened to the point of .042" (1 mm) (dime) clearance is reached between the coils of the 1-1/4" idler tension springs and .068" (1.7 mm) (nickel) clearance is reached between the coils of the 1-3/4" idler tension springs.

LOADING INSTRUCTIONS & PRECAUTIONS

- A.** Do not add side board extensions to the mixer.
- B.** Do not overload the mixer. Mixer capacity can be reached by weight or volume. By volume, the rotor bars and wipers should always be visible at the peak of the rotor cycle. If the rotor is completely submerged under the mix, mixing efficiency may be reduced, spillage may occur, and damage to the mixer may result. Maximum capacity by weight can be calculated by multiplying 28 pounds times mixer cubic foot capacity.
- C.** Load molasses and/or liquid protein supplements first with mixer not running, then add one (1) commodity ingredient before starting the mixer. For the shortest mixing time and maximum mixing efficiency, these items should be added at the first of the loading process.
- D.** When adding minute supplements or medication in non-liquid form, these ingredients should be loaded in the middle of the loading sequence.

E. RATIONS WITH GROUND HAY:

- 1. Load molasses (or liquids) first with the mixer not running.
- 2. Load one (1) commodity ingredient and start mixer.
- 3. Finish loading commodities, silage, or ground hay. Loading ground hay after mixing liquids with another commodity will prevent molasses hay balls.

NOTE: These procedures may not work on all rations. Loading sequences may be changed to give best possible mix.

ATTENTION:

- F.** Never load the mixer from the right side (side opposite the discharge) with a front end loader or payloader while the mixer is running.

OPERATION:

Trailer mounted mixers can be furnished with single tractor controls or dual controls. Dual controls are standard unless specified.

1. Single controls operate as follows: Spout goes down first - door opens second. Door closes first - spout goes up second.
2. The disadvantage of the single control is that it does not let you adjust the spout height without first closing the door.

ROTO-HAY PROCESSOR

The ROTO-HAY PROCESSOR is designed for processing hay into the mixer. This eliminates the need for grinding hay, which saves the time and expense of grinding and can save up to 18% loss from wind and handling.

THE ROTO-HAY PROCESSOR MUST BE PROPERLY USED ALWAYS USE DRY HAY

Drain rain water out of mixer before use. 1" of rain in a 620-16XD equals (78 gal) 650 lbs. of water which will increase the moisture in 1000 lbs. of dry hay (12%) to 46% moisture or 500 lbs. of dry hay to 61% moisture.

The ROTO-HAY PROCESSOR will handle small amounts of damp hay, but this is done at your own risk. ROTO-MIX will not warranty bent or broken rotor tubes, bent or broken augers, or bent hay pans caused from misuse, wet hay, foreign objects, and/or overloading.

HAY PREPARATION:

1. **SMALL BALES** - (60 to 150 lbs., 2 or 3 wire) Remove twine or wire from bales and break bales apart by pushing into a pole with a front end loader.
2. **LARGE SQUARE BALES** - (3' x 4' x 8' or 4' x 4' x 8')
 - A. Position bale so you can get to end of bale with front end loader.
 - B. Remove twine or wrapping.
 - C. With front end loader, pull a 12" flake away from the bale so it can be picked up with loader bucket - or - by adding 3 or 4 teeth (12" long) to the top of your loader bucket, you can stab the end of the bale and pick up a 12" flake to lay on the mixer hay pan.
3. **ROUND BALES**
 - A. Remove twine or wrapping.
 - B. Cut bale with a ROTO-BALE CUTTER a minimum of 5 times to part the bale into a minimum of 12" chunks. More times may be desired for ease of handling.
 - C. Break bales apart by pushing into a pole with a front end loader so the hay can be loaded in quantities of approximately 200 lbs. at a time.

LOADING INSTRUCTIONS FOR HAY PROCESSOR

Load all commodities except liquids on the discharge (auger) side with the hay pan in the raised position. The raised hay pan does not affect the mixing action

1. If molasses and/or liquid protein is used, load on the rotor side of the mixer first with the mixer not running.
2. Load one (1) grain or dry commodity in a minimum amount equal to the amount of hay to be put into mixer with the mixer not running.
3. Start the mixer and run approximately one (1) minute before adding hay.
4. With the mixer running at a minimum rotor speed of 4 RPM, load prepared hay towards the front of the hay pan on discharge side of mixer. For best results, when loading with a tractor front end loader or payloader, each bucket load should not exceed 200 lbs at one time. Allow time for the hay to be processed into the mixer before loading another 200 lbs. Repeat until desired amount of hay is processed (DO NOT OVERLOAD). Let the mixer run until desired length of hay is reached.
5. Finish loading dry commodities.
6. Load wet feeds, such as silage, after all commodities and hay are in the feed mixer.
7. If water is to be added to the ration - **Do this last!**

MIXER INFORMATION

The mixer trailers are equipped with recapped tires with a new tread cap.

ADJUST TRAILER HITCH CLEVIS

Mixer should be approximately level when attached to tractor.

Adjust clevis by changing hole location on tongue.

Hitch Pin Size — 1" x 7"

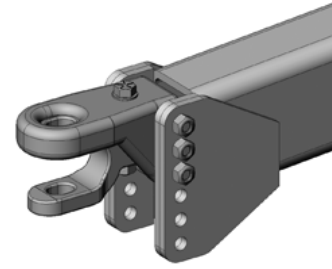

LUBRICATION

DISENGAGE PTO & SHUT OFF POWER BEFORE LUBRICATING THE MACHINE.

LOOSE OR FLOPPY CLOTHING SHOULD NOT BE WORN BY THE OPERATOR.

OIL BATH: Fill the oil bath with 30 weight motor oil to sight plug level.

GREASE BANK: Grease every 10 hours.

FRONT END BEARINGS: Grease every 10 hours.

INPUT BEARINGS: One (1) on input shaft beneath mixer/feeder. Grease every 10 hours.

PTO SHAFTS & U-JOINTS: Grease every 10 to 20 hours.

HYDRAULIC PUMP DRIVE: Grease every 10 to 20 hours.

2:1 GEARBOX: Prior to operation, remove the uppermost plug and replace with vent plug provided. After the first 100 hours of operation, drain the initial oil, preferably warm. Flush the gear case with an approved non-flammable, non-toxic solvent and refill with oil. Thereafter oil should be changed every 2000 hours or every 12 months, whichever occurs first. Fill the gearbox with approximately 2-1/2 pints (1.2 liters) of (**Mobil Delvac Synthetic Gear Oil 75W-90**).

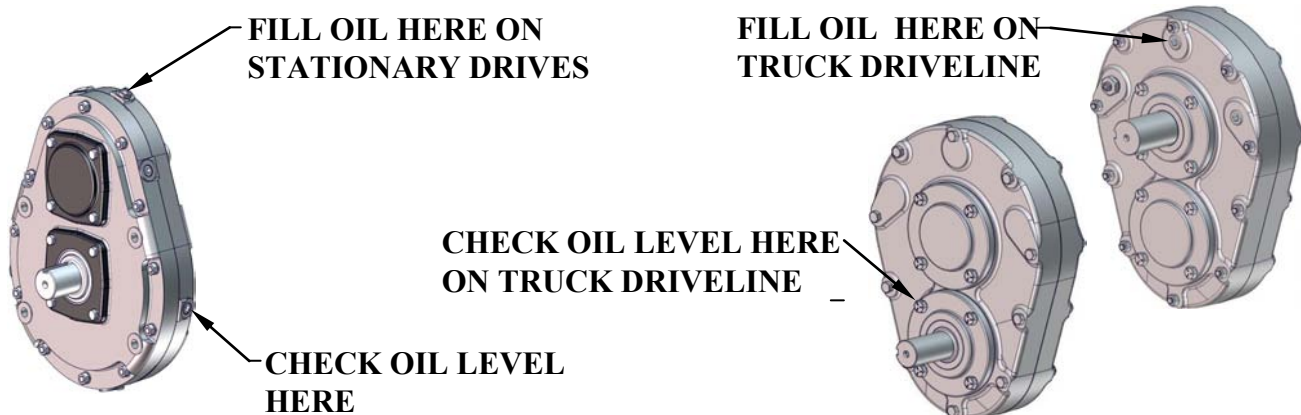

MIXER DOOR CYLINDER HYDRAULICS (TRUCK): Replace hydraulic filter after first 100 hours of operation then every 500 hours of operation with 10 micron element. Replace fluid every 2000 hours of operation or every year, which ever occurs first, with approximately 1 gallon (3.7 liters) of (**CITGO TRANSGARD TRACTOR HYDRAULIC FLUID - Material Code 633310001**).

This Page intentionally left blank.

620-16XD SPECIFICATIONS

Capacity (Cu. ft.).....	620
Struck level capacity (Cu. ft.)	680
Top Auger Bearing (Front).....	2-7/16" 4-Bolt
Top Auger Bearing (Rear)	4" 4-Bolt
Bottom Auger Bearing (Front).....	2-7/16" 4-Bolt
Bottom Auger Bearing (Rear)	4" 4-Bolt
Rotor Bearing (Front).....	3-7/16" 4-Bolt
Rotor Bearing (Rear)	9-3/4" NYLATRON
Top Auger Flighting	3/8" x 24"OD RH 16"P (STANDARD)
.....	1/2" x 24"OD RH 16"P (OPTIONAL)
Bottom Auger Flighting	1/2" x 24"OD RH & LH FULL PITCH (STD)
.....	3/4" x 24"OD RH & LH FULL PITCH (OPT)
Tub Bottom Construction	1/4" Steel (STD), 3/8" Steel (OPT)
Auger Bottom Construction.....	3/8" Steel (STD)
Right Side Sheet Construction.....	3/16" Steel
Left Side Sheet Construction	3/16" Steel
Front End Sheet Construction	1/4" Steel
Rear End Sheet Construction	1/4" Steel

PTO CHART 620XD-16

	PTO (% ENGINE SPEED)	GEARBOX RATIO	INPUT SPROCKET	JACKSHAFT SPROCKET
DIESEL	(80-85)			
AUTOMATIC	250 ft./lb. min.	2:1 Gearbox	17 Tooth	17 Tooth
TRANS	Engine rotation			48 Tooth

(For other engine or transmission applications, consult factory.)

**1000 PTO
TRACTOR DRIVE
(STANDARD)**

17 Tooth 17 Tooth
48 Tooth

**540 PTO
TRACTOR
DRIVE
(OPTIONAL – REQUIRES HEAVY DRIVELINE)**

23 Tooth 17 Tooth
48 Tooth

STATIONARY 1750 RPM ELECTRIC	BELT RATIO
	50HP 5V-3 Groove 16" & 5V-4 Groove 10.9" 3 Belts 5V-1060
	40HP 5V-3 Groove 16" & 5V-4 Groove 10.9" 3 Belts 5V-1060

NOTE: IF OPTIONAL HAY PROCESSOR IS INSTALLED A 50HP MOTOR IS REQUIRED.

620-16XD TRUCK DIMENSIONS

**HEIGHT DIMENSIONS BASED ON
38" TRUCK FRAME**

**ADD 3 1/2" TO HEIGHT IF CROSS
OVER BARS ARE INSTALLED.**

APPROXIMATE WEIGHT
620-16XD ON TRUCK..... 16,500 lb
W/HAY PROCESSOR..... 17,500 lb

	14" SPOUT	24" SPOUT
A	35-1/2"	28"
B	40"	34"
C	26"	35"
D	18"	26"

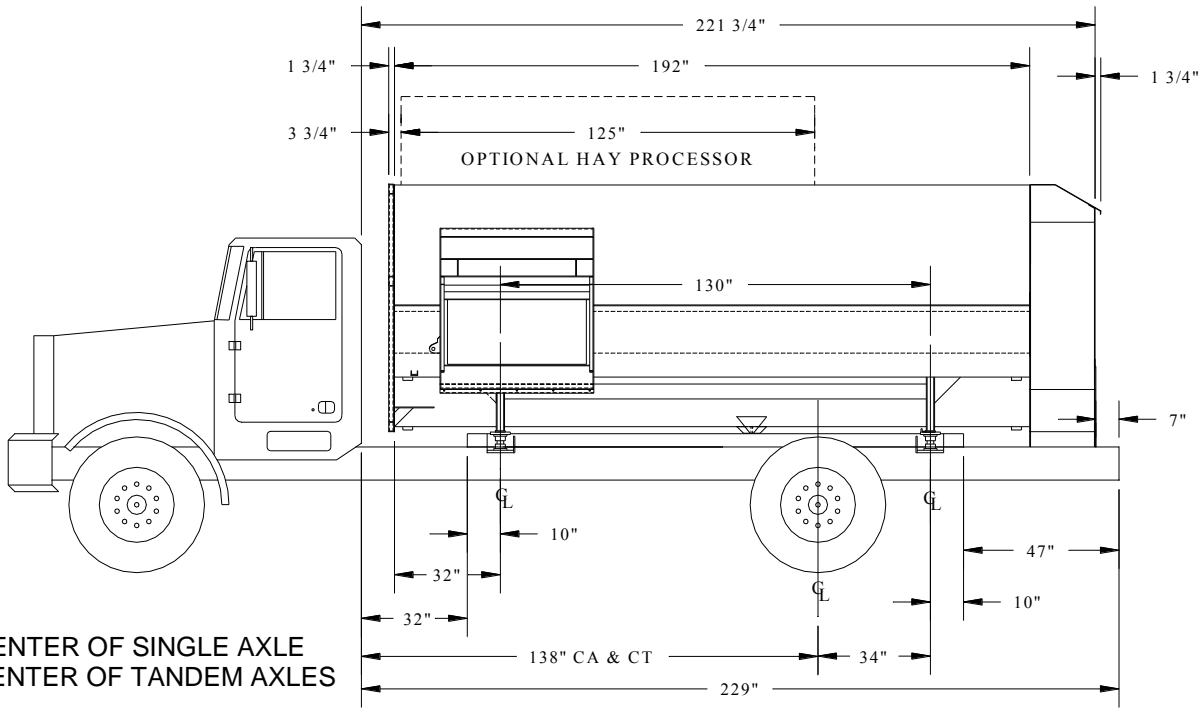
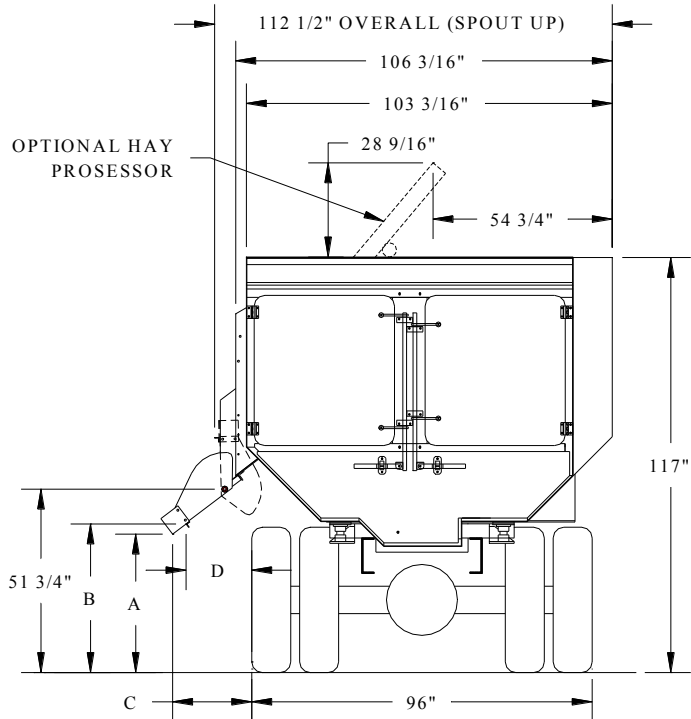

CA - CENTER OF SINGLE AXLE
 CT - CENTER OF TANDEM AXLES

620-16XD TRUCK MOUNTING DIMENSIONS

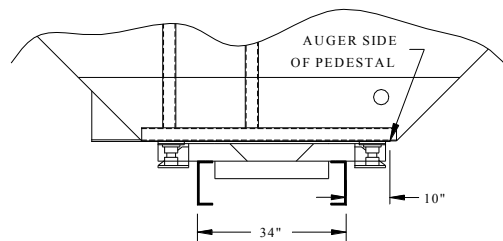

All Dimensions & Specifications are Approximate and Subject to Change Without Notice.

620-16XD STATIONARY DIMENSIONS

APPROXIMATE WEIGHT LESS MOTOR

**620-16XD STATIONARY ..16,200 lb
W/HAY PROCESSOR17,200 lb**

**NOTE: ADD 3 1/2" TO HEIGHT IF
CROSS OVER BARS ARE INSTALLED.**

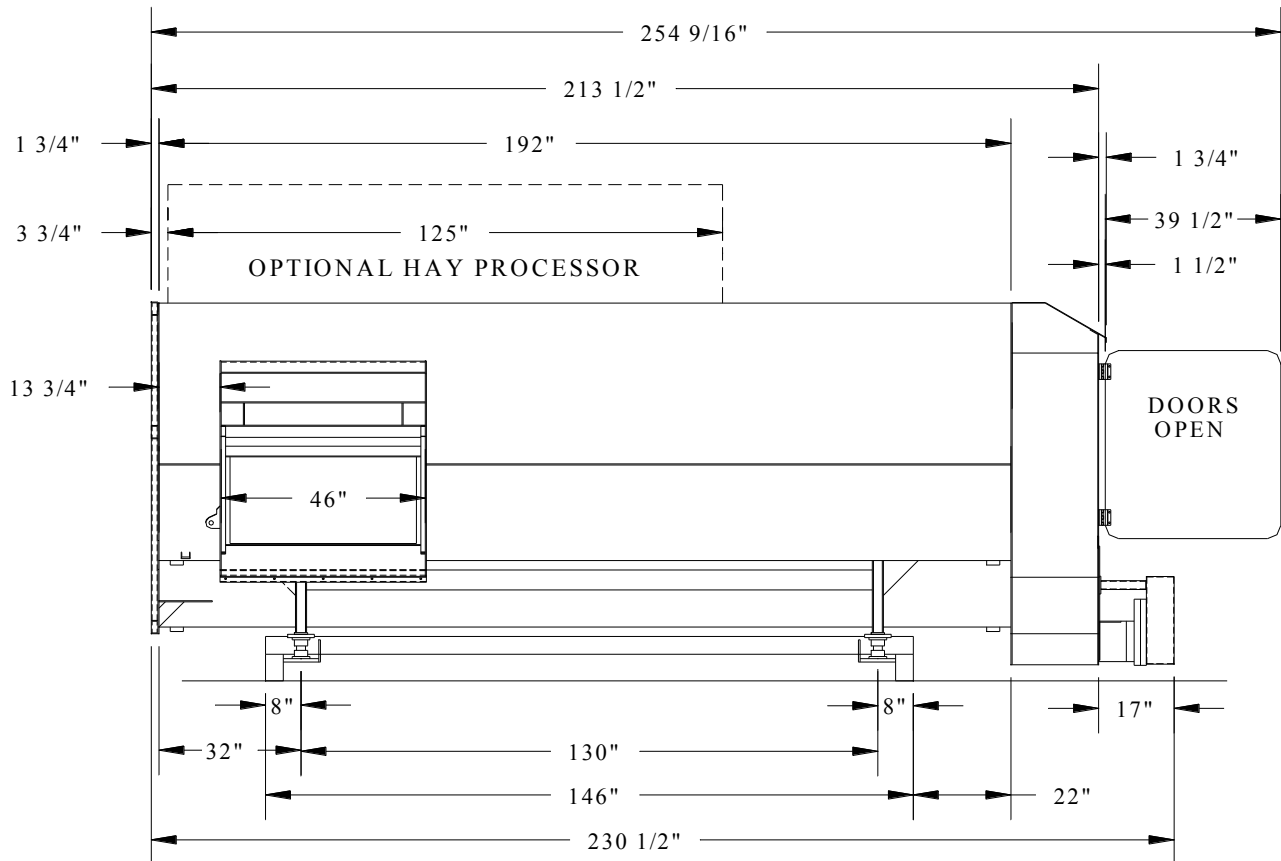
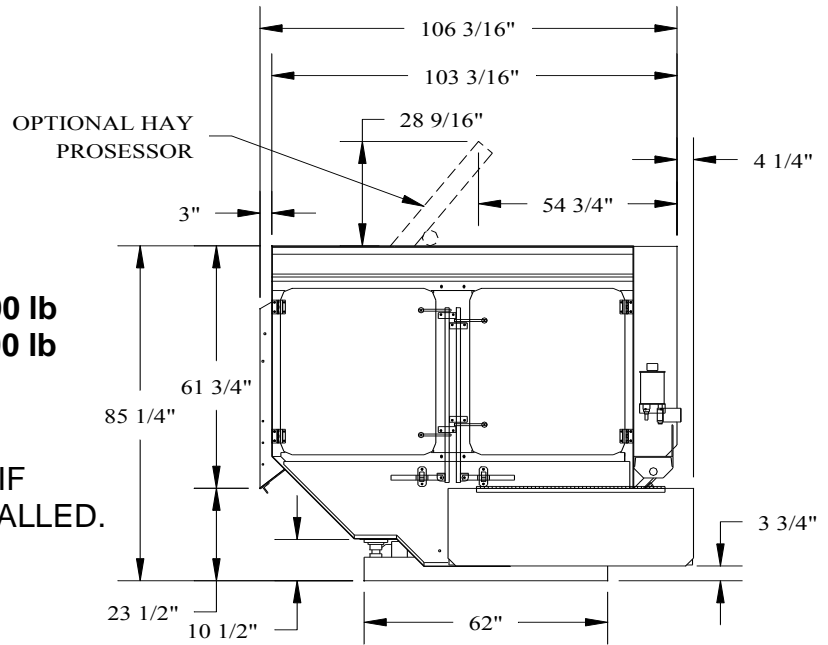

All Dimensions & Specifications are Approximate and Subject to Change Without Notice.

620-16XD TRAILER DIMENSIONS

HEIGHT DIMENSIONS ARE BASED ON A 43" O.D. TIRE .

ADD 3 1/2" TO HEIGHT IF CROSS OVER BARS ARE INSTALLED.

**APPROXIMATE WEIGHT
620-16XD ON TRAILER... 18,300 lb
W/HAY PROCESSOR..... 19,300 lb**

	14 SPOUT	24" SPOUT
A	29"	21 1/2"
B	33 1/2"	27 1/2"
C	28"	32"
D	20"	24"

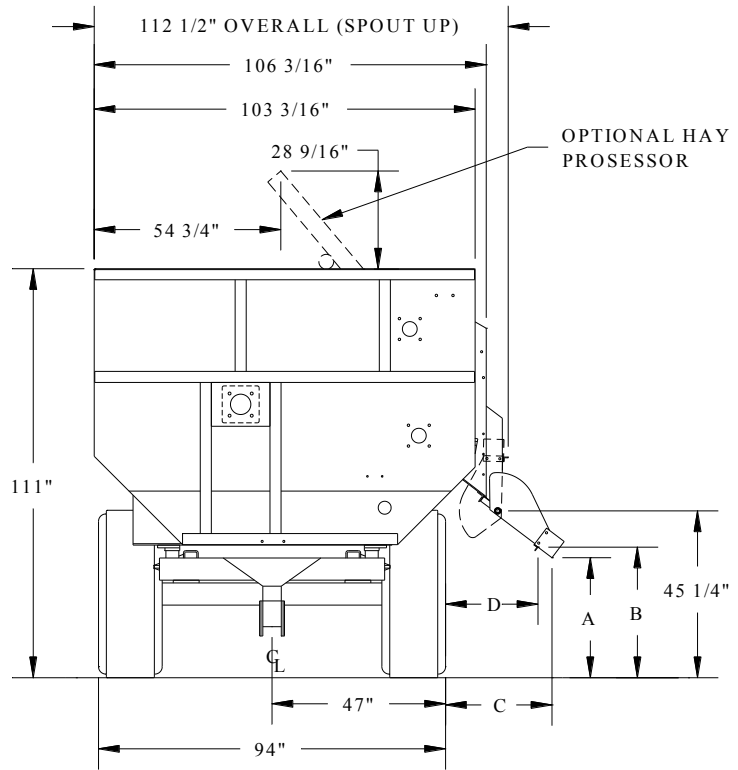

NOTE: TIRES CAN BE MOVED IN OR OUT 4" ON EACH SIDE BY 2" INCREMENTS .

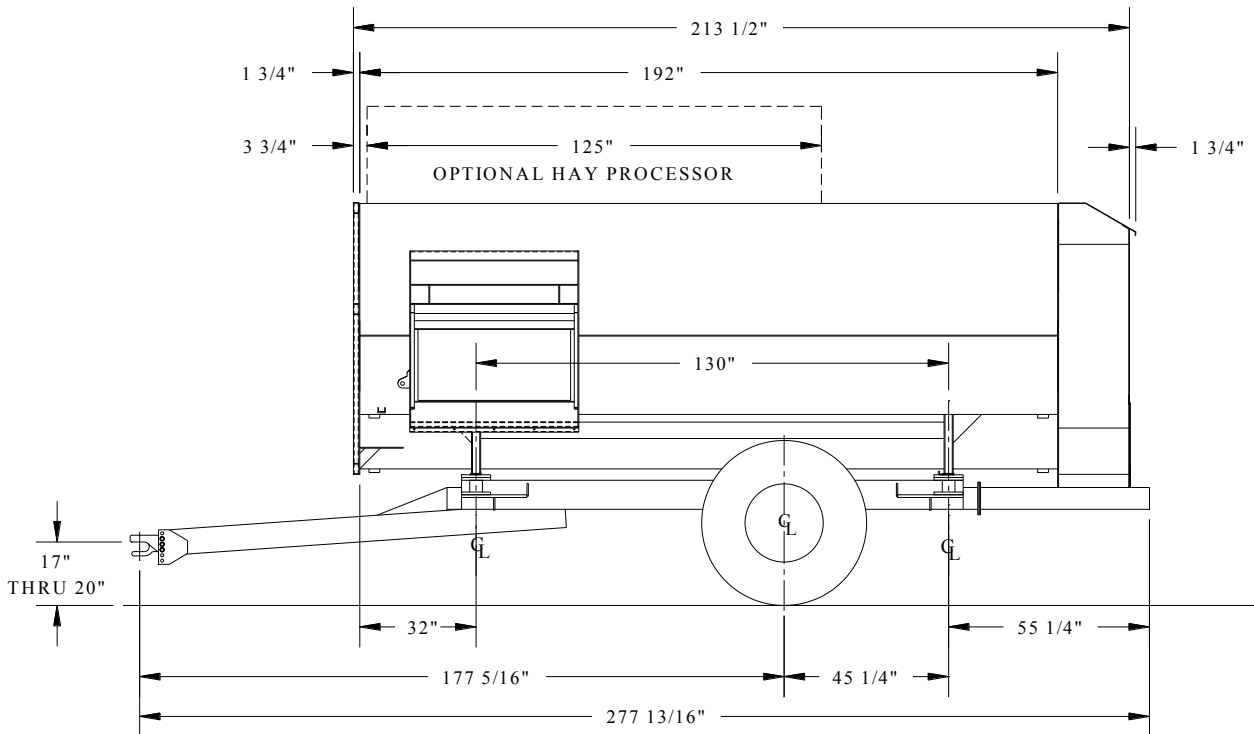

All Dimensions & Specifications are Approximate and Subject to Change Without Notice.

620-16XD TRAILER DIMENSIONS

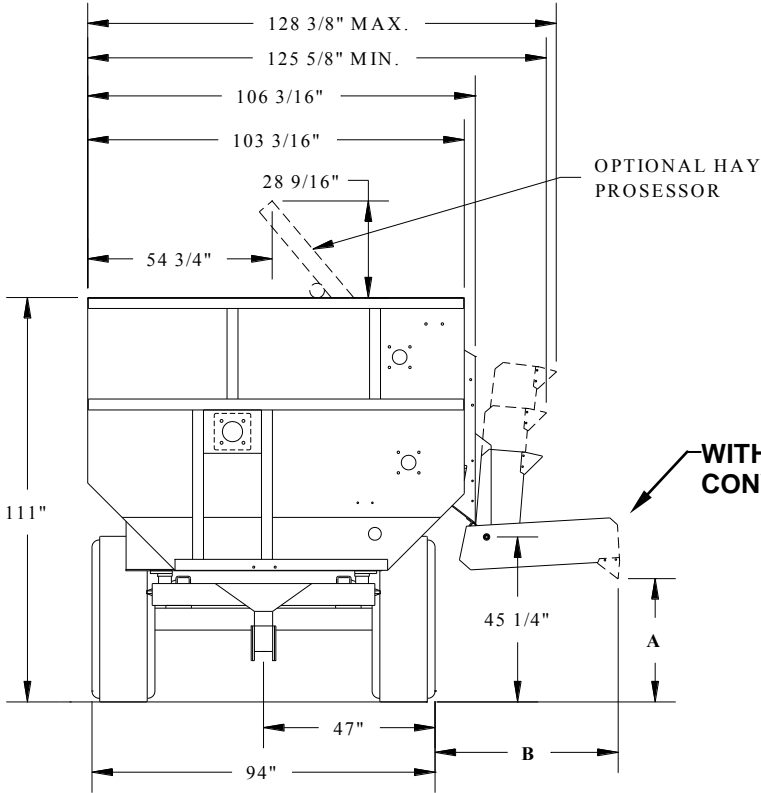

CONVEYOR WEIGHT

- 24" 330LB.
- 36" 415LB.
- 48" 500LB.

	24" CONV.		36" CONV.		48" CONV.	
	@0°	@30°	@0°	@30°	@0°	@30°
A	33"	47"	34"	53"	35"	59"
B	38"	36"	50"	48"	62"	60"

620-16XD TRAILER MOUNTING DIMENSIONS

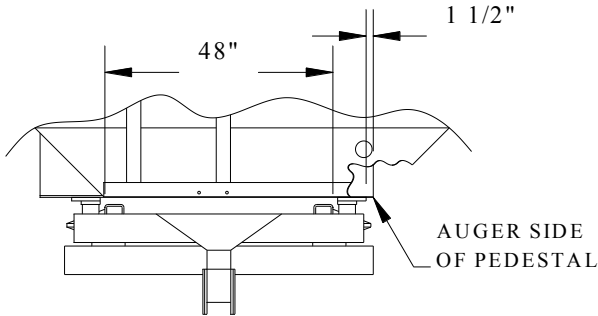

All Dimensions & Specifications are Approximate and Subject to Change Without Notice.

How to read a Roto-Mix Serial Number

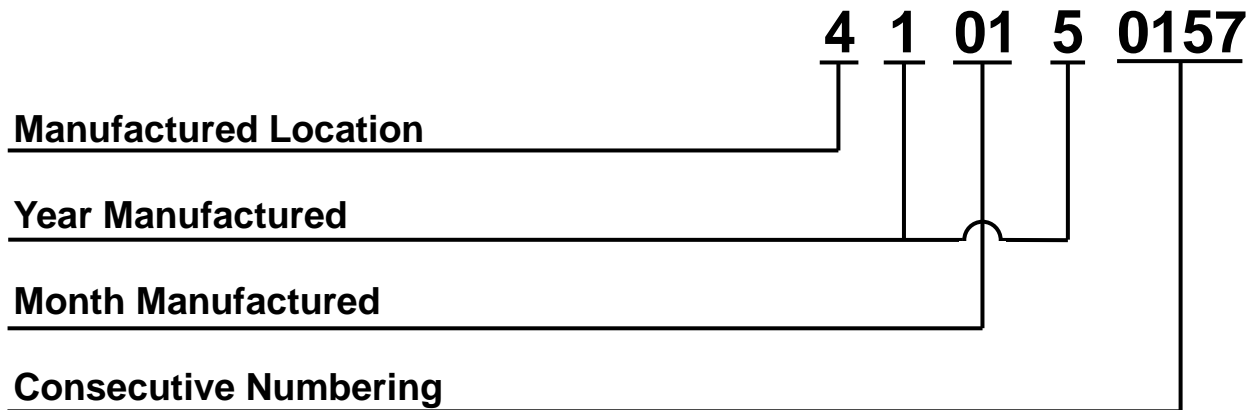

PART PAGES TABLE OF CONTENTS

DESCRIPTION	PAGE #
WIRING SCHEMATIC FOR STRAIGHT DOOR	34
PUSH BUTTON SWITCH PANEL ASSEMBLY	35
JOYSTICK ASSEMBLY.....	36
CONTROL PANEL ASSEMBLY	37
DOUBLE HYDRAULIC VALVE ASSY 12V	38
HYDRAULIC PUMP	40
OIL RESERVOIR	41
HYDRAULIC SCHEMATIC STRAIGHT DOOR.....	42
STATIONARY HYDRAULIC SCHEMATIC	43
SPOUT ASSEMBLY.....	44-46
DISCHARGE DOOR AND CONVEYOR ASSEMBLY.....	47-51
ROTOR ASSEMBLY	52-55
TOP AUGER.....	56-59
BOTTOM AUGER	60-61
620-16XD DRIVE ASSEMBLY	62-67
620-16 DRIVE ASSEMBLY	68-69
STATIONARY ELECTRIC DRIVE	70-71
ELECTRIC HYDRAULIC POWER UNIT	72
GEARBOX ASSEMBLY	74-75
TRUCK DRIVELINE ASSEMBLY	76-77
TRAILER DRIVELINE ASSEMBLY	78-79
FRONT END BEARING ASSEMBLY	82
TRUCK LOAD CELL SCALE FRAME ASSEMBLY	83
TRUCK WEIGH BAR SCALE FRAME ASSEMBLY.....	84
SCALE INDICATOR ARM ASSEMBLY	85
TRAILER LOAD CELL SCALE FRAME ASSEMBLY.....	86
TRAILER WEIGH BAR SCALE FRAME ASSEMBLY	87
STATIONARY LOAD CELL SCALE FRAME ASSEMBLY	88
TRAILER ASSEMBLY.....	89
TRAILER HUB & SPINDLE ASSEMBLY	90-91
OIL BATH DOOR ASSEMBLY	92-93
ROTO-HAY PROCESSOR ASSEMBLY	94-96
CROSS OVER BAR & HAY SHEAR BAR	97
FENDERS.....	98
OIL BATH & FRONT END SHEET LUBE LINE ASSEMBLIES.....	99-101
LADDER OPTION.....	102
TRUCK CAB SCALE INDICATOR FRAME PARTS	103
SHELL REPAIR PARTS.....	104-105
TRUCK BUMPERS	106-110

620-16XD WIRING SCHEMATIC DISCHARGE DOOR

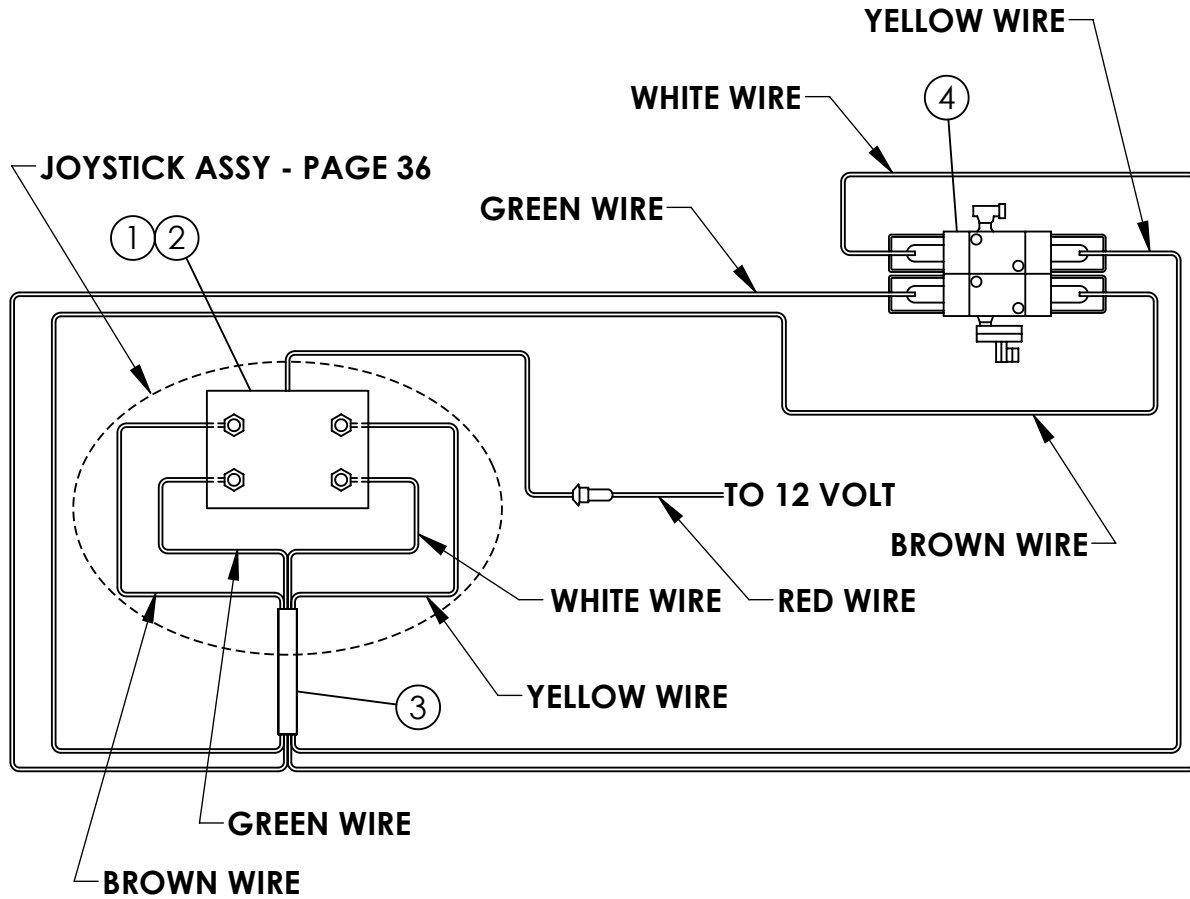

REF #	PART #	DESCRIPTION	QTY.
1	780080	PUSH BUTTON SWITCH PANEL ASSY (See page 35)	1
2	780081	JOYSTICK SWITCH PANEL ASSY (See page 36)	1
3	781055	TRUCK TO MIXER WIRE ASSY	1
4	780123	HYDRAULIC CONTROL VALVE (See page 38)	1

620-16XD PUSH BUTTON SWITCH PANEL

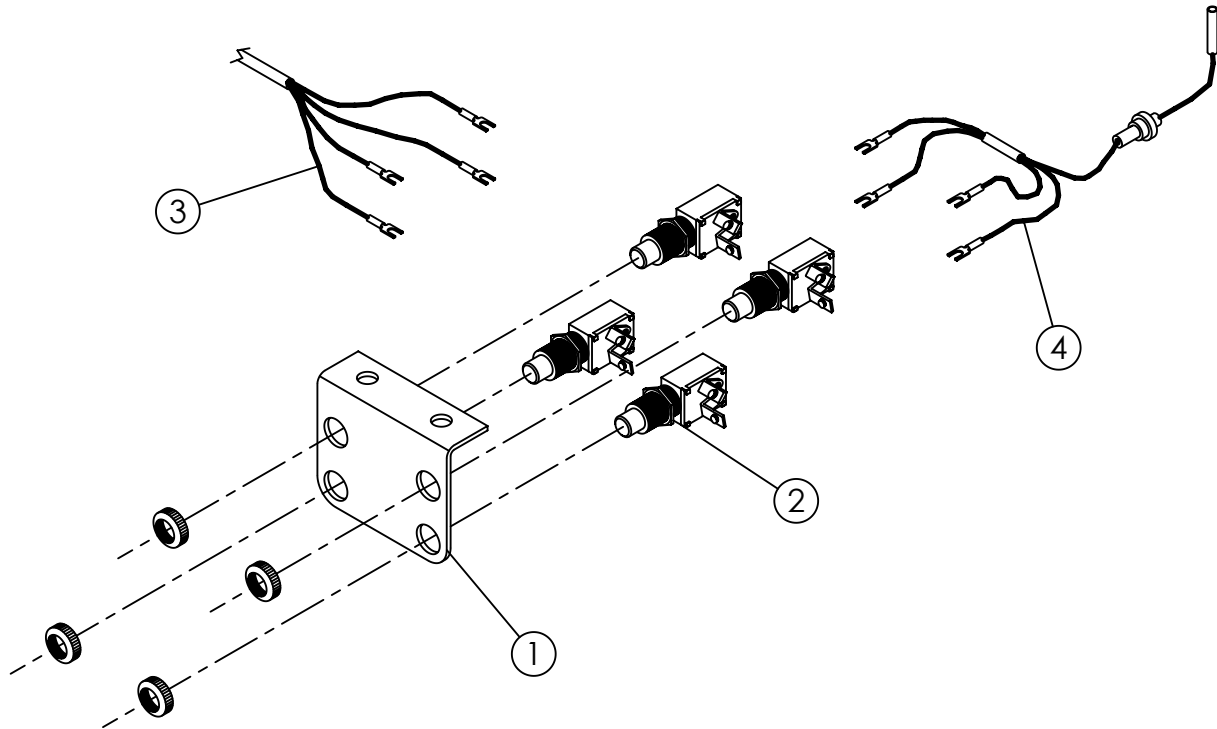

REF #	PART #	DESCRIPTION	QTY.
1	183392	SWITCH PANEL	1
2	357702	PUSH BUTTON SWITCH	4
3	781055	TRUCK TO MIXER WIRE ASSEMBLY	1
4	781056	SWITCH WIRE ASSEMBLY	1

620-16XD JOYSTICK ASSEMBLY

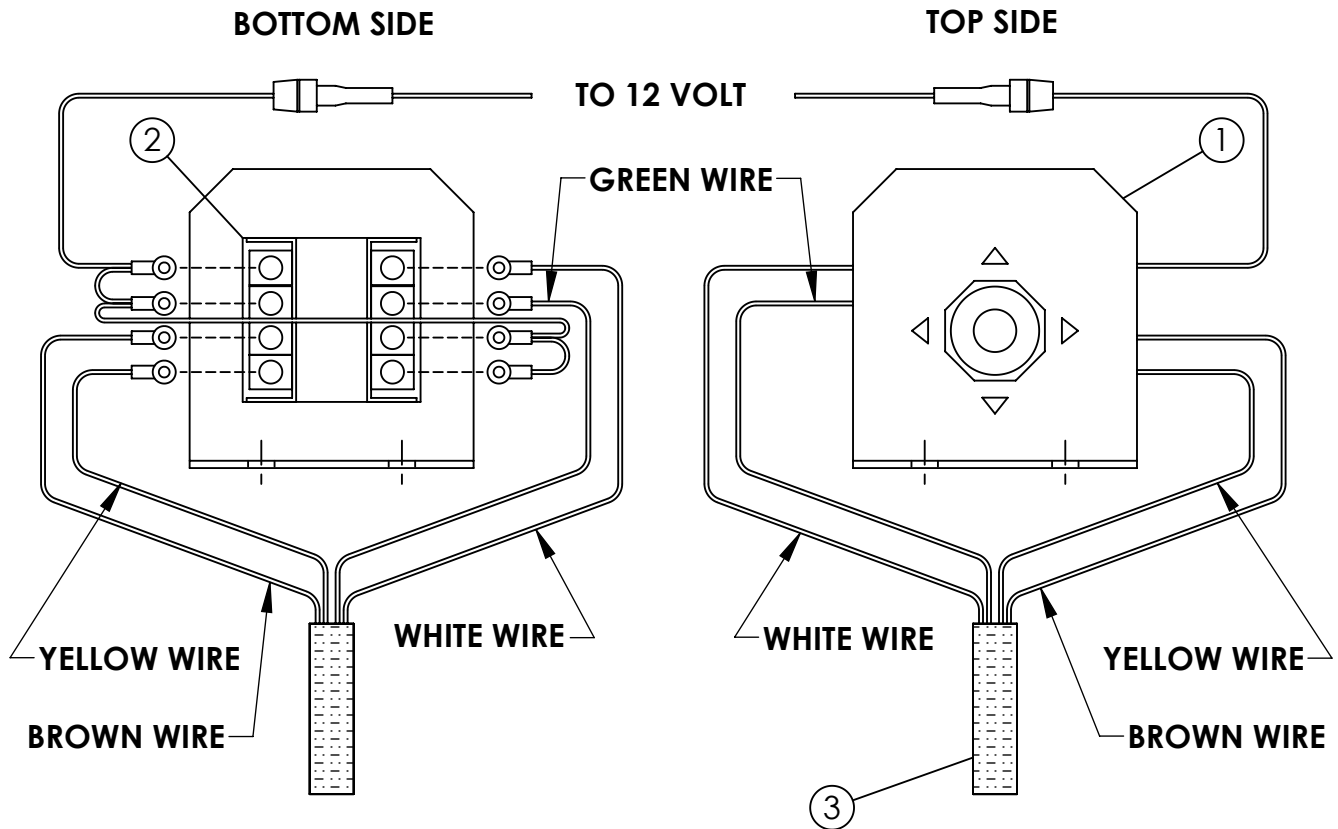

REF #	PART #	DESCRIPTION	QTY.
1	185575	JOYSTICK BRACKET	1
2	357705	JOYSTICK SWITCH	1
3	781056	SWITCH WIRE ASSEMBLY	1

620-16XD JOYSTICK CONTROL PANEL & WIRING

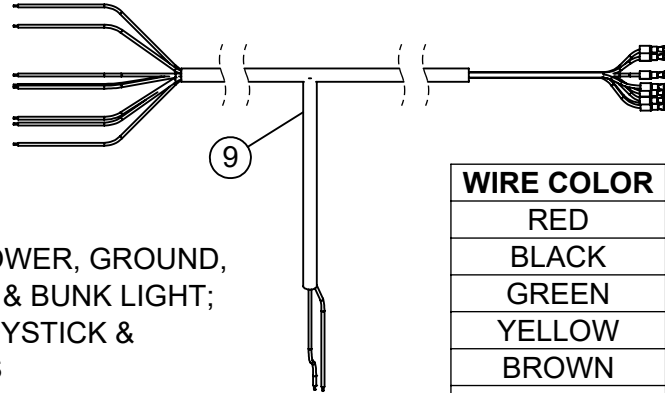

BARE ENDS FOR POWER, GROUND, HYDRAULIC VALVE, & BUNK LIGHT; FORK ENDS FOR JOYSTICK & ROCKER SWITCHES

WIRE COLOR	FUNCTION
RED	POWER
BLACK	GROUND
GREEN	DOOR STACK VALVE
YELLOW	DOOR STACK VALVE
BROWN	SPOUT STACK VALVE
WHITE	SPOUT STACK VALVE
PURPLE	BUNK LIGHTS

USE DIN CONNECTORS FOR HYDRAULIC STACK VALVE

USE HARNESS SUPPLIED WITH PTO FOR PTO SWITCH & LIGHT

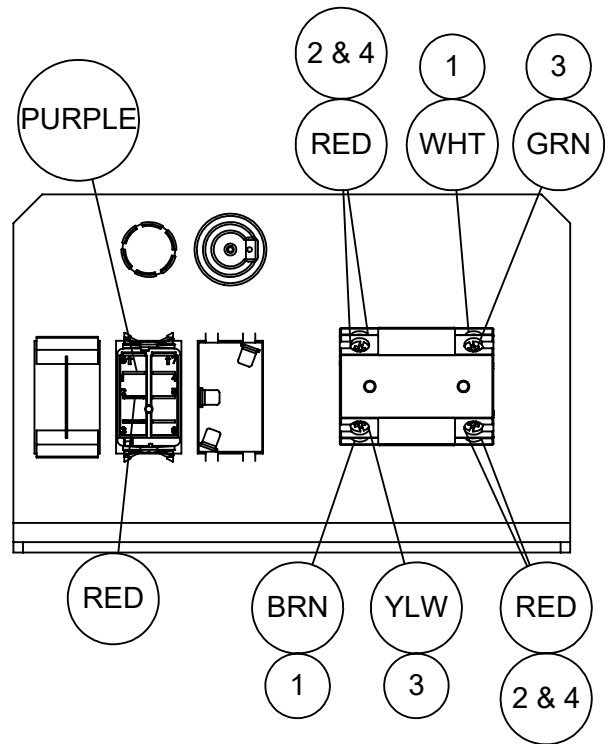
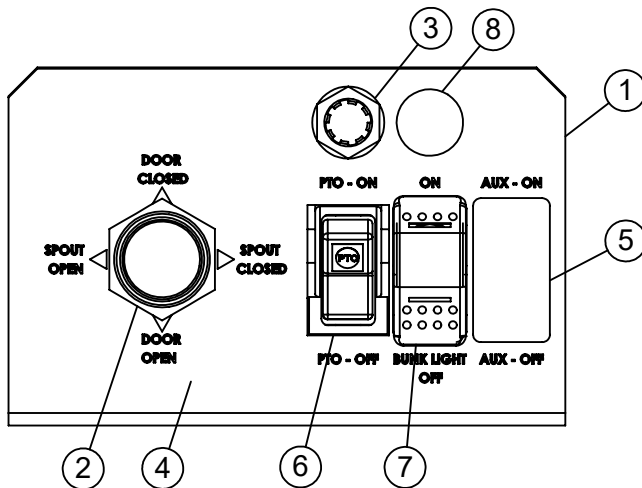

ITEM #	PART #	DESCRIPTION	QTY.
1	190928	TRUCK SWITCH PANEL	1
2	357705	JOYSTICK, (4-WAY) SCHNEIDER 9001K35	1
3	357753	LIGHT, RED INDICATOR, 3/4" DIA.	1
4	440835	DECAL, 4-WAY JOYSTICK - HORIZONTAL	1
5	452726	PLUG, PANEL	1
6	452730	SWITCH, ROCKER ON-OFF	1
7	452744	SWITCH, ROCKER ON-OFF, SPST	1
8	452763	PLUG, PANEL 11/16" DIA	1
9	781055	TRUCK TO MIXER WIRE ASSY	1

620-16XD DOUBLE HYDRAULIC VALVE

#780123

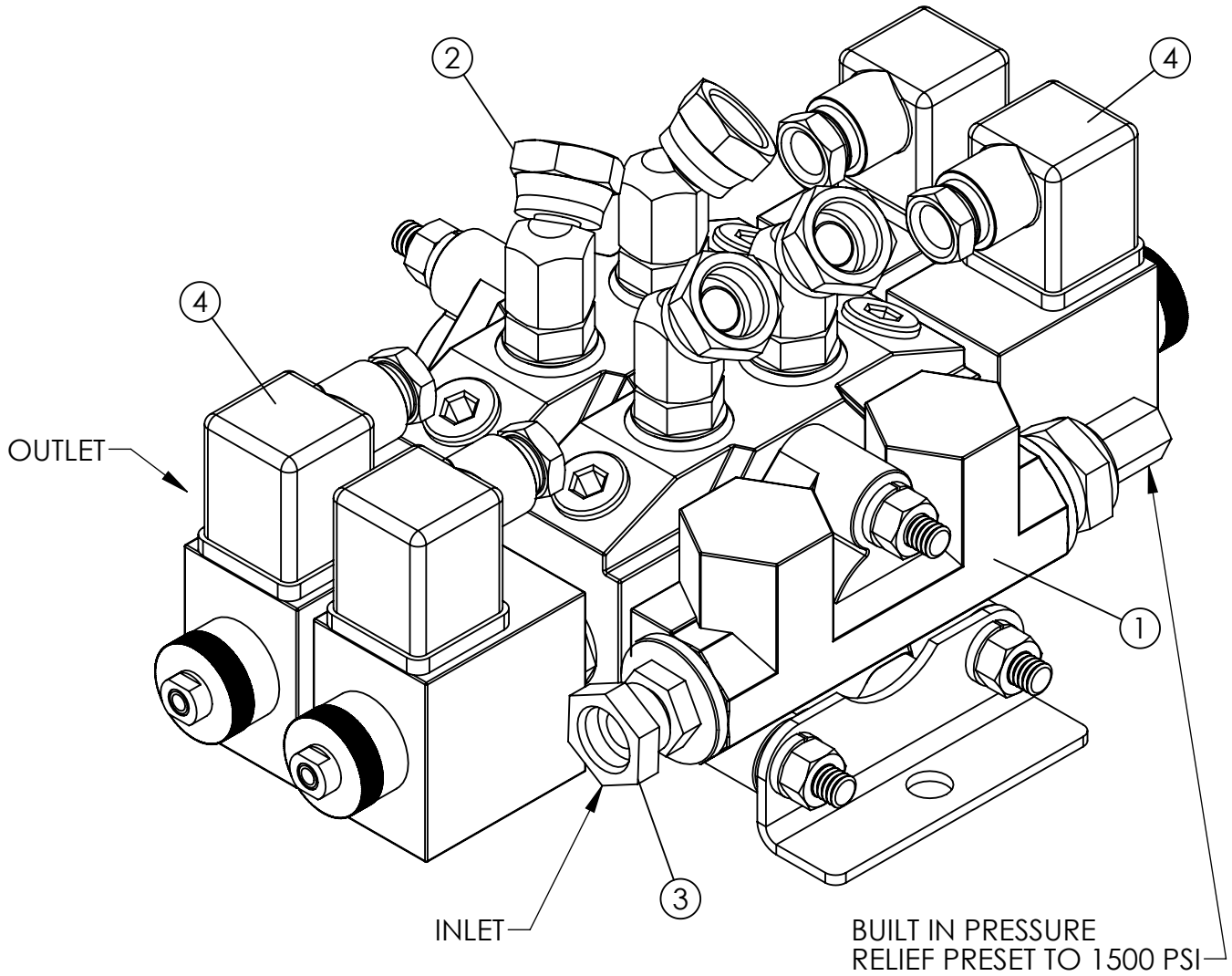

ITEM #	PART #	DESCRIPTION	QTY.
1	362209	HYD VALVE 12V DOUBLE, BUCHER	1
2	368024	HYD SWIVEL 9/16" MOR x 3/8" FPS 45°	4
3	368115	STRAIGHT ADAPTER 9/16 MOR x 3/8 FPS	2
4	453146	DIN CONNECTOR	4

620-16XD POWER STEERING HYDRAULICS

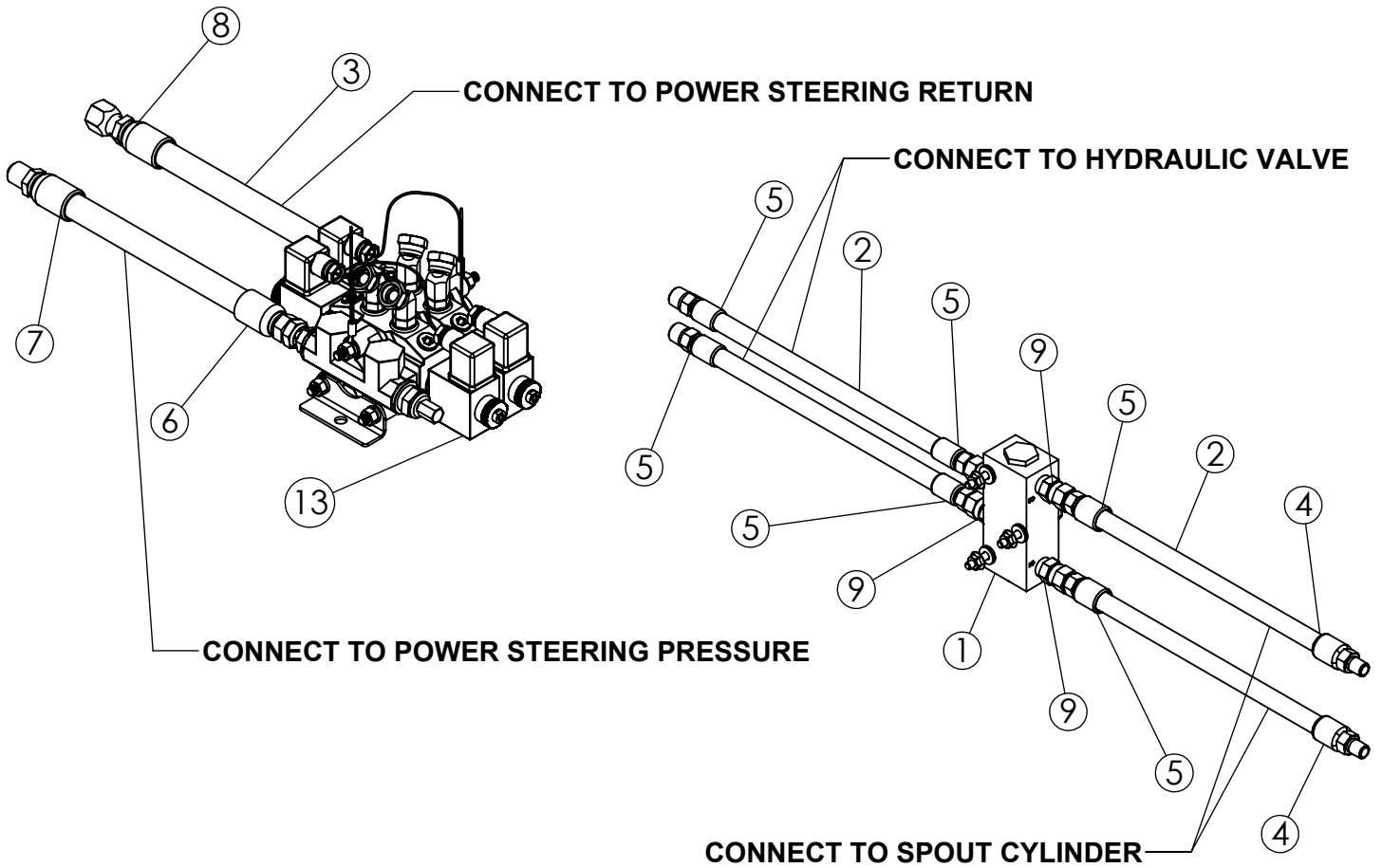

ITEM#	PART#	DESCRIPTION	QTY.
1	362219	DOUBLE PILOT OPERATED CHECK VALVE 3/8" PIPE	1
2	366006	3/8" HYDRAULIC HOSE	AS NEEDED
3	366008	1/2" HYDRAULIC HOSE	AS NEEDED
4	367064	HOSE COUPLING, 3/8" x 1/4" MP MEGACRIMP	2
5	367066	HOSE COUPLING, 3/8" x 3/8" MP MEGACRIMP	6
6	367086	HOSE STEM, 1/2" x 3/8"MP	2
7	367093	HOSE COUPLING 1/2" x 3/4"MJX ,8G-8FJX	1
8	367101	HOSE COUPLING 1/2" x 3/4"FJX ,8G-8FJX	1
9	368110	HYD ADAPTER 3/8MP x 3/8FP SWIVEL	4
10	400113	FLANGE HEX NUT, 1/4"-20 SERRATED	3
11	402404	FLAT WASHER 1/4" PLTD	6
12	405610	HHCS 1/4"-20 x 2 1/2" #5 PLTD	3
13	780123	DBL HYD VALVE ASSY-TRK	1

620-16XD HYDRAULIC PUMP

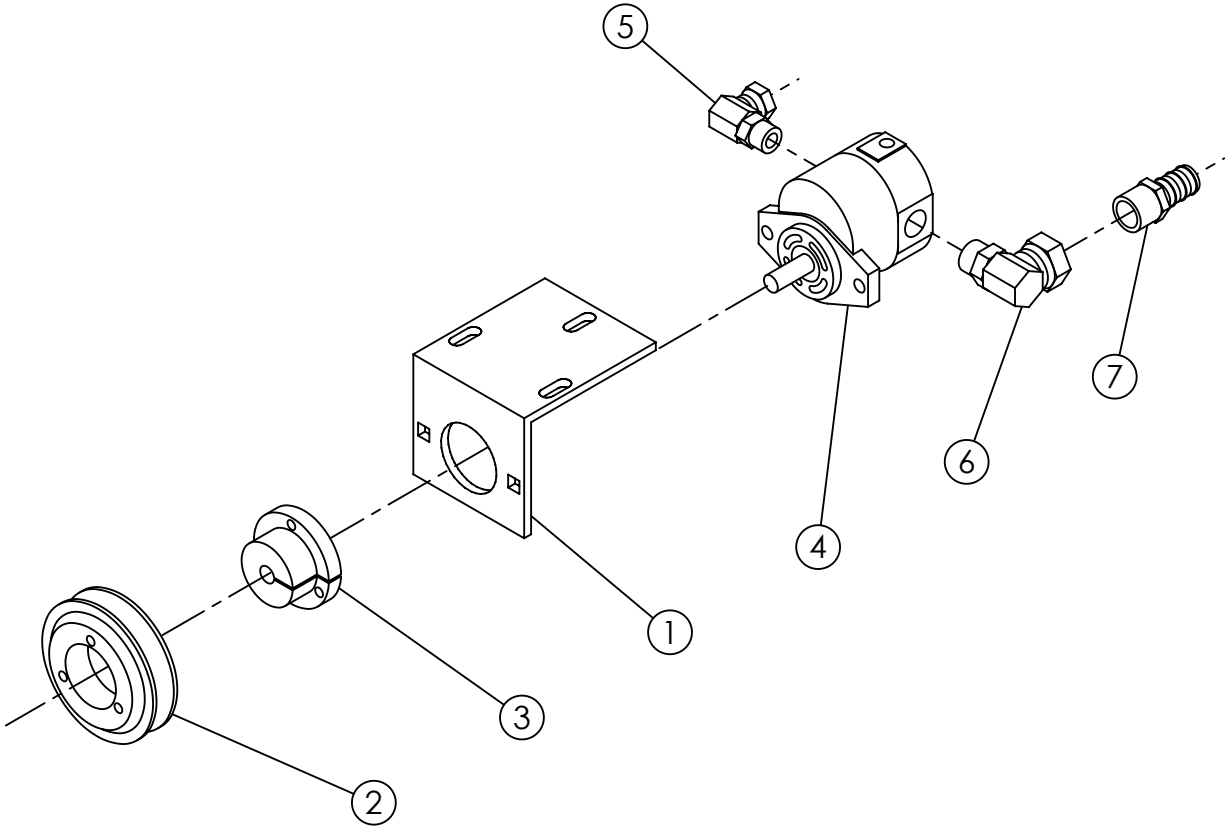

REF #	PART #	DESCRIPTION	QTY.
1	182766	HYDRAULIC PUMP BRACKET	1
2	324040	1B x 4.0" SH BELT SHEAVE	1
3	336008	SH BUSHING 1/2" BORE	1
4	362017	HYDRAULIC PUMP	1
5	368040	3/8" FP x 3/4" MOR 90o SWIVEL	1
6	368050	3/4" FP x 7/8" MOR 90o SWIVEL	1
7	368512	3/4" MP x 3/4" HOSE BARB	1

620-16XD OIL RESERVOIR

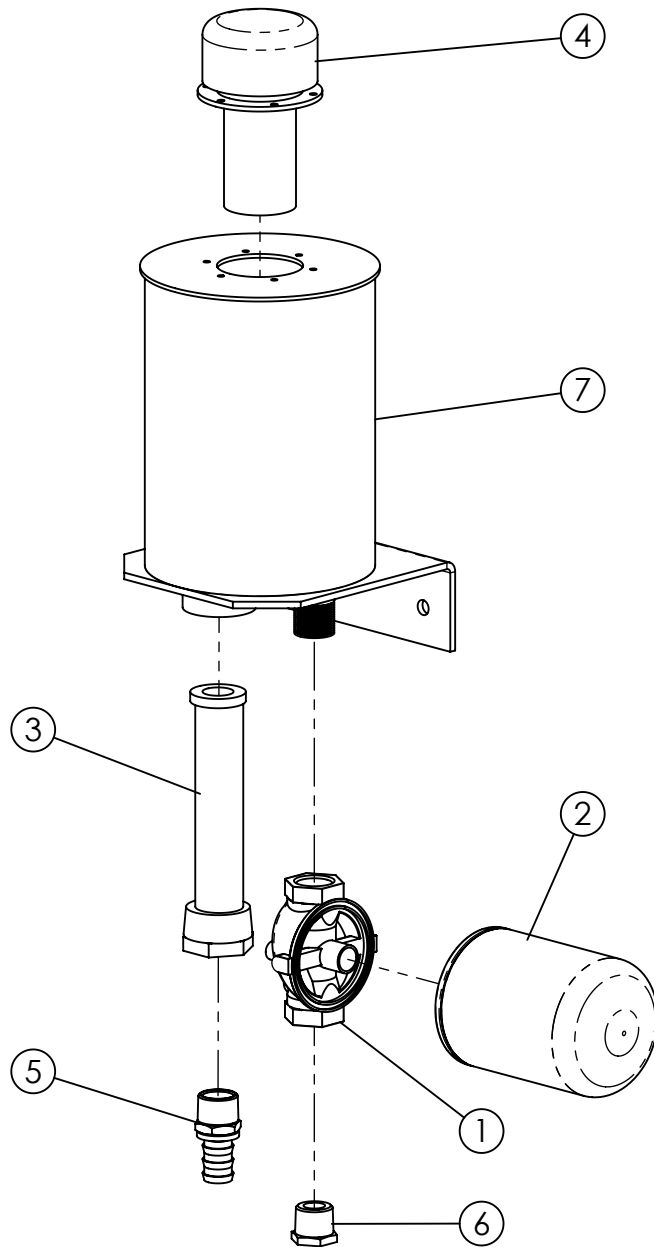

ITEM #	PART #	DESCRIPTION	QTY
1	362403	FILTER HEAD 3/4", ZAF-07-25-0	1
2	362440	FILTER ELEMENT - AE-10	1
3	362504	SUCTION SCREEN	1
4	362550	FILLER CAP ASSY. FLOE EZY - AB1000-3	1
5	368512	PUSH LOCK HOSE BARB (3/4)x 3/4" MP	1
6	368612	STEEL BUSHING 3/4"MP x 3/8"FP	1
7	870477	OIL RESERVOIR W.A.	1

620-16XD HYDRAULIC SCHEMATIC TRUCK DISCHARGE DOOR

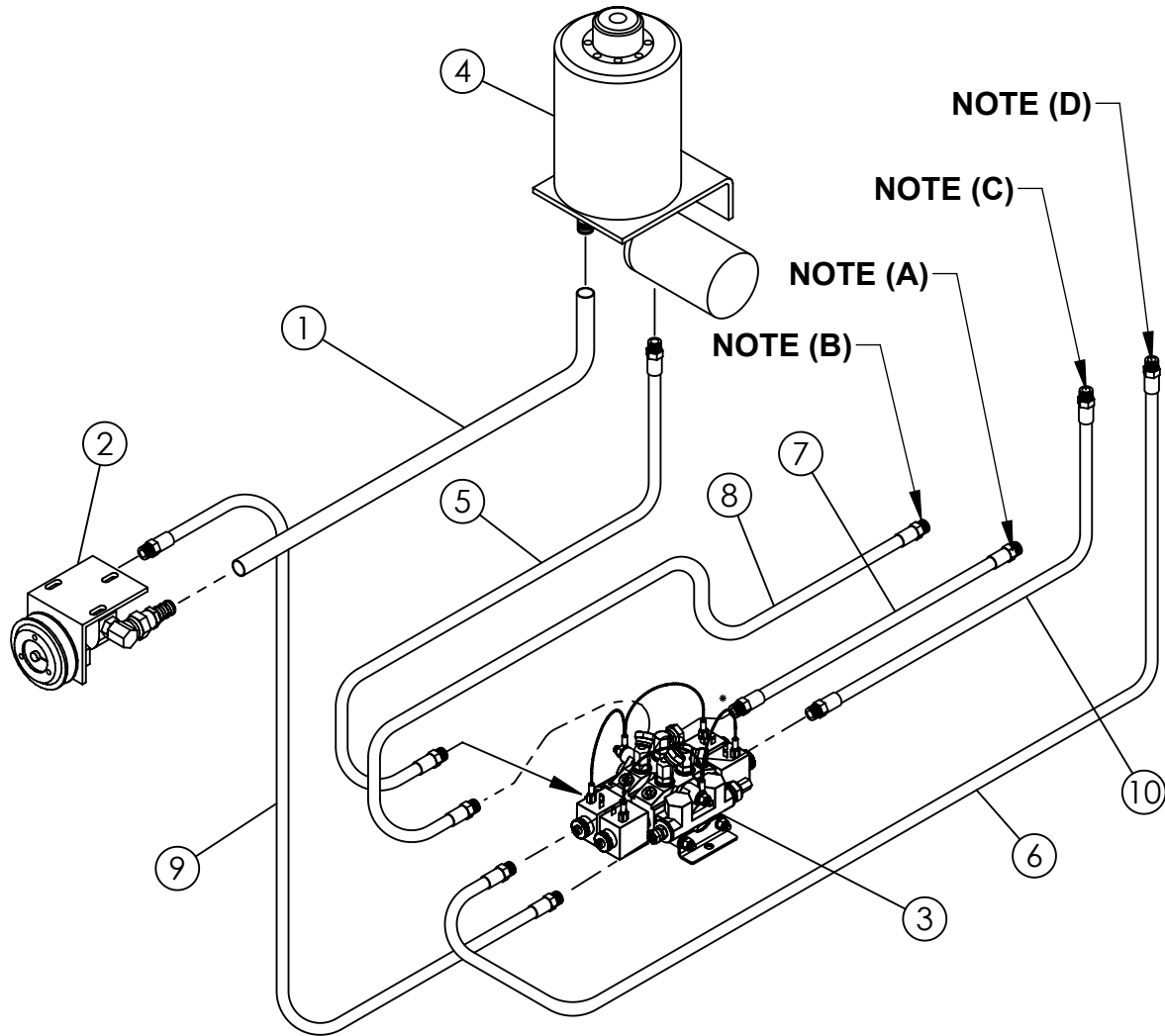

NOTE A: CONNECT TO SPOUT CYLINDER BASE
NOTE B: CONNECT TO SPOUT CYLINDER ROD END
NOTE C: CONNECT TO DOOR CYLINDER BASE
NOTE D: CONNECT TO DOOR CYLINDER ROD END

REF #	PART #	DESCRIPTION	QTY.
1	184291	HYD. HOSE ASSY. 3/4" x 144" (SUCTION LINE)	1
2	780064	HYDRAULIC PUMP ASSEMBLY	1
3	780123	HYDRAULIC VALVE ASSEMBLY	1
4	780205	RESERVOIR ASSEMBLY	1
5	781059	HYD. HOSE ASSY. 3/8" x 20" w/3/8" MP ENDS	1
6	781061	HYD. HOSE ASSY. w/3/8" MP ENDS	1
7	781066	HYD. HOSE ASSY. w/3/8" MP & 1/4" MP ENDS	1
8	781069	HYD. HOSE ASSY. w/3/8" MP & 1/4" MP ENDS	1
9	781073	HYD. HOSE ASSY. 3/8" x 144" w/3/8" MP ENDS	1
10	781098	HYD. HOSE ASSY. w/3/8" MP ENDS	1

620-16XD HYDRAULIC SCHEMATIC STATIONARY DISCHARGE DOOR

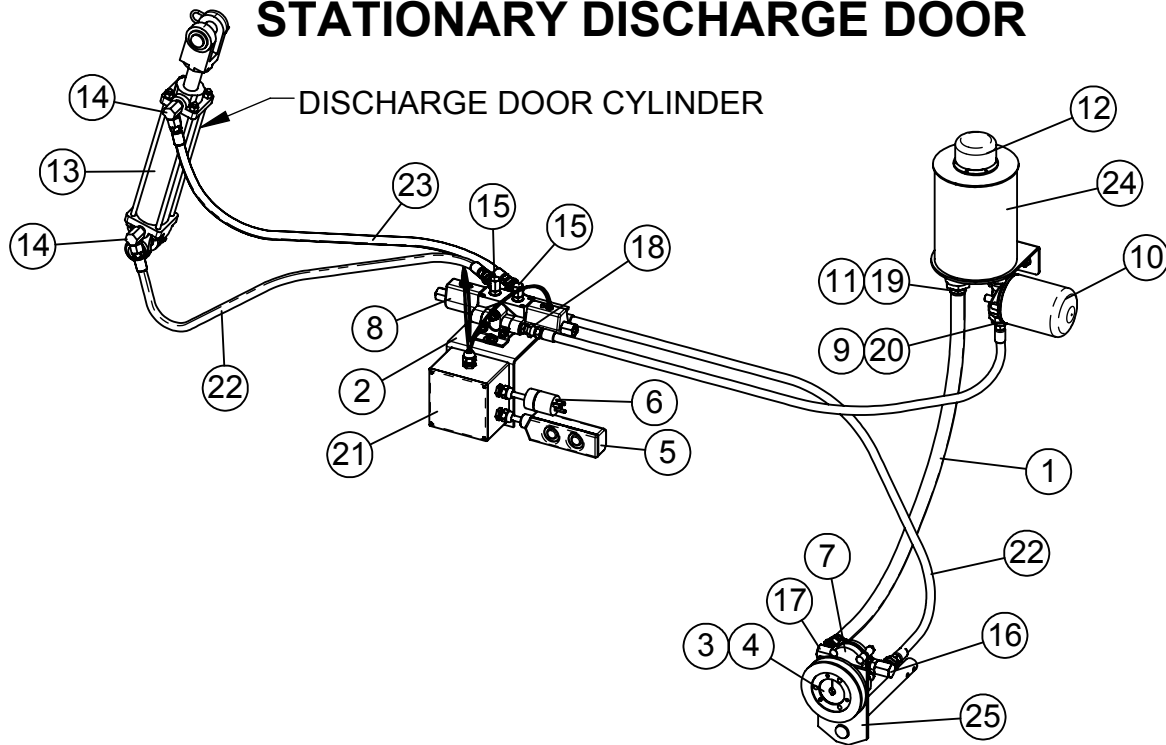

ITEM #	PART #	DESCRIPTION	QTY.
1	189088	SUCTION HOSE 3/4" x 94"	1
2	189250	ELECTRIC SOLENOID BRACKET - 5 1/2" x 14"	1
3	324046	BELT SHEAVE 1B x 4.6	1
4	336009	BUSHING, SDS 1/2" QD	1
5	357700	SWITCH - HW 4052 PENDANT	1
6	358410	MALE PLUG - WH 1447 120V	1
7	362010	PARKER PUMP - D05AA1A CCW	1
8	362205	Hyd Valve 120V Sngl MV5	1
9	362403	FILTER HEAD 3/4", ZAF-07-25-0	1
10	362440	FILTER ELEMENT - AE-10	1
11	362504	SUCTION SCREEN	1
12	362550	FILLER CAP ASSY. FLOE EZY - AB1000-3	1
13	364055	HYDRAULIC CYLINDER 2" x 8", 20-1/4" CC	1
14	368007	HYDRAULIC ADAPTER 3/8"MP x 3/8"FPX 90° .109 orifice	2
15	368030	HYD SWIVEL 9/16"MOR x 3/8"FPS 90°	2
16	368040	HYD SWIVEL 3/4" MOR x 3/8"FP 90°	1
17	368050	ADAPTER 7/8 MOR x 3/4 FPS 90	1
18	368115	STRAIGHT ADAPTER 9/16 MOR x 3/8 FPS	2
19	368512	PUSH LOCK HOSE BARB (3/4)x 3/4" MP	2
20	368612	STEEL BUSHING 3/4"MP x 3/8"FP	1
21	453717	J-BOX SHELL	1
22	781075	HYD HOSE ASSY, 3/8" x 180" - 3/8" x 3/8"MP	2
23	781077	HYD HOSE ASSY, 3/8" x 192" - 3/8" x 3/8"MP	2
24	870477	OIL RESERVOIR W.A.	1
25	872138	PUMP SWING ARM	1

620-16XD SPOUT ASSEMBLY

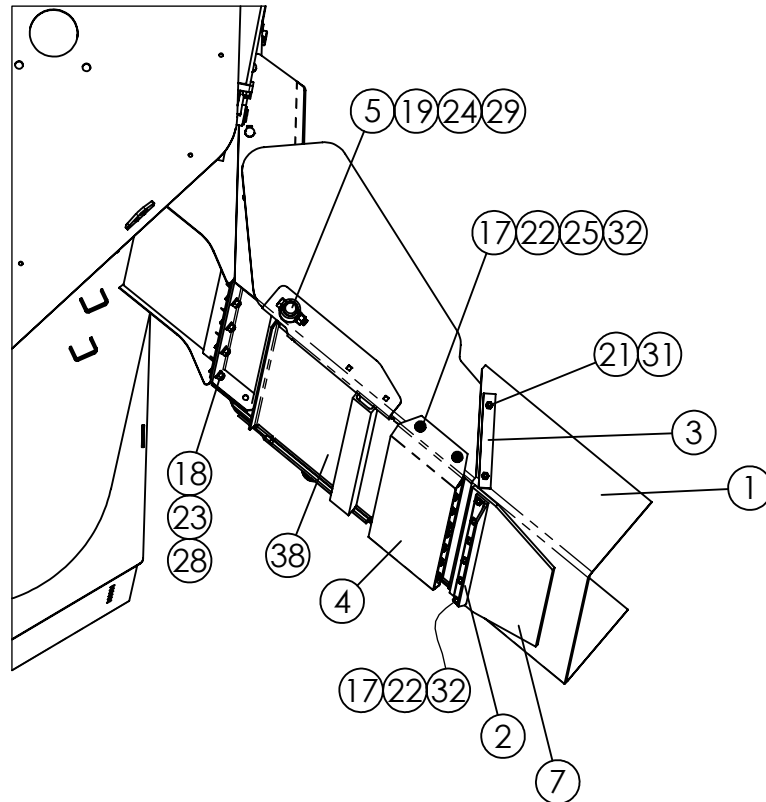
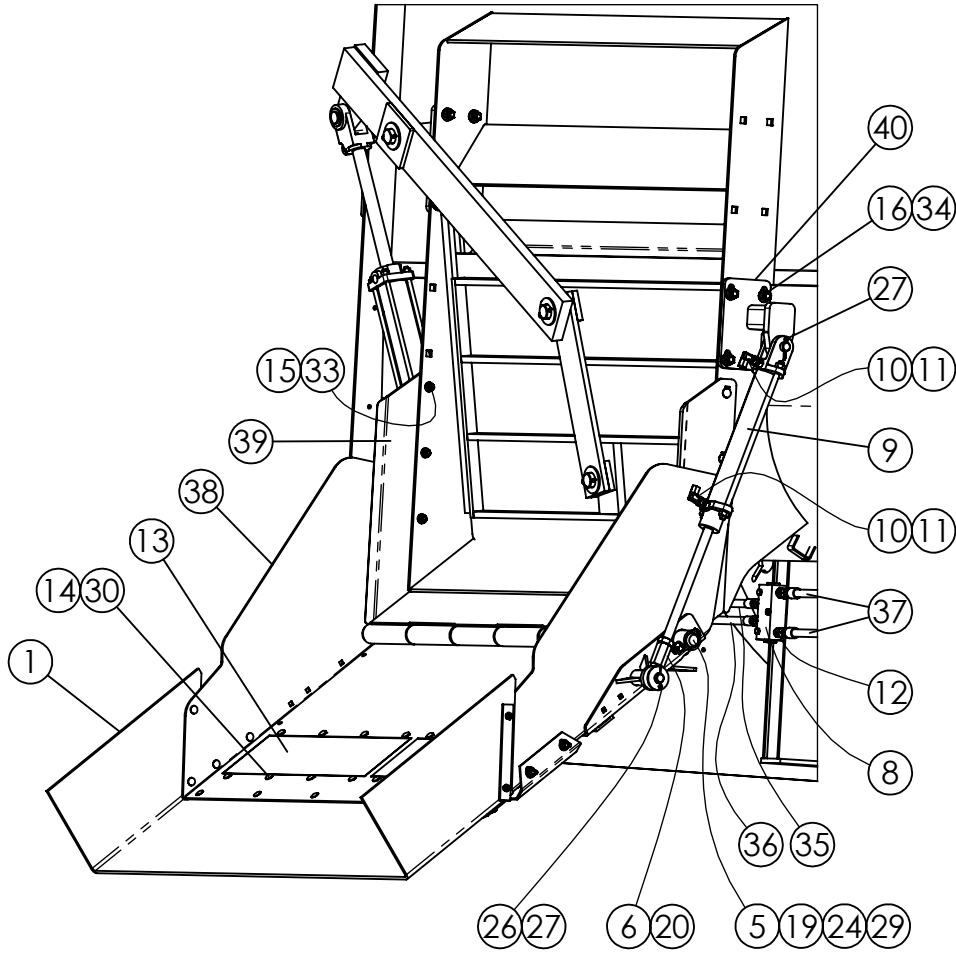

620-16XD SPOUT ASSEMBLY

ITEM #	PART #	DESCRIPTION	QTY.
1	183145	SPOUT RUBBER 16" x 64"	1
2	183152	SPOUT BACKUP ANGLE, 47"	1
3	183160	SPOUT RUBBER SIDE BAR x 8"	2
4	189079	SPOUT MAGNET GUARD, 24" XD	1
	190865	SPOUT MAGNET GUARD, 14" XD	-
5	190758	SPOUT SHAFT	1
6	192019P	SPOUT CYLINDER ROD END (DANUSER)	1
7	192118P	SPOUT RUBBER SUPPORT (540/920)	1
8	362219	DOUBLE PILOT OPERATED CHECK VALVE, 3/8" NPT PORTS	1
9	364078	HYD CYL 1-1/2 x 10 x 17-3/16 (LESS CLEVIS)	1
10	368011	HYD ADAPTER, 1/4MP x 1/4FPX 90° 1/16"ORIFICE	2
11	368106	STR. 9/16"MOR x 1/4"FP SWIVEL	2
12	368110	HYD ADAPTER, STRAIGHT 3/8MP x 3/8FP SWIVEL	4
13	375005	ACRO PLATE MAGNET AM 2200,	2
14	400106	HEX NUT, 5/16"-18 SER. FLANGE #5 PLTD	16
15	400107	HEX NUT, 3/8"-16 SERRATED FLANGE #5	6
16	400114	HEX NUT, 1/2-13 SERRATED FLANGE #5	3
17	400205	HEX NUT 5/16"-18 #5 PLTD	11
18	400206	HEX NUT 3/8"-16 #5 PLTD	5
19	400208	HEX NUT 1/2"-13 #5 PLTD	2
20	400712	HEX JAM NUT 3/4"-16	1
21	400905	HEX CROWN LOCNUT 5/16"-18 G5 PLT	4
22	402005	WASHER 5/16", SPRING LOCK, MED PLTD	11
23	402006	WASHER SPRING LOCK 3/8" MED PLTD	5
24	402008	SPRING LOCK WASHER 1/2" PLTD	2
25	402405	FLAT WASHER MED PLTD 5/16"	4
26	402412	FLAT WASHER 3/4" PLTD	1
27	404002	COTTER PIN 3/16" x 1 1/2"	3
28	405653	HHCS 3/8"-16 x 1" #5 PLTD	5
29	405707	HHCS 1/2"-13 x 2-1/2" #5 PLTD	2
30	407020	CHCS 5/16"-18 x 3/4" #5 PLTD	16
31	407021	CHCS 5/16"-18 x 1" #5 PLTD	4
32	407022	CHCS 5/16"-18 x 1-1/4"	11
33	407040	CHCS 3/8"-16 x 1" #5 PLTD	6
34	407101	CHCS 1/2"-13 x 1-1/4" #5 PLTD	3
35	781918	HOSE ASM, 3/8" x 17", 3/8MP x 3/8MP	1
36	781919	HOSE ASM, 3/8" x 18", 3/8MP x 3/8MP	1
37	781920	HOSE ASM, HYD 3/8" x 66", 3/8MP x 1/4MP	2
38	873138	SPOUT WA, 24" XD	1
	873197	SPOUT WA, 14" XD	-
39	873261	SPOUT HINGE W.A. 620 XD	1
40	875572	SPOUT CYLINDER BRACKET WA	1

620-16 SPOUT ASSEMBLY

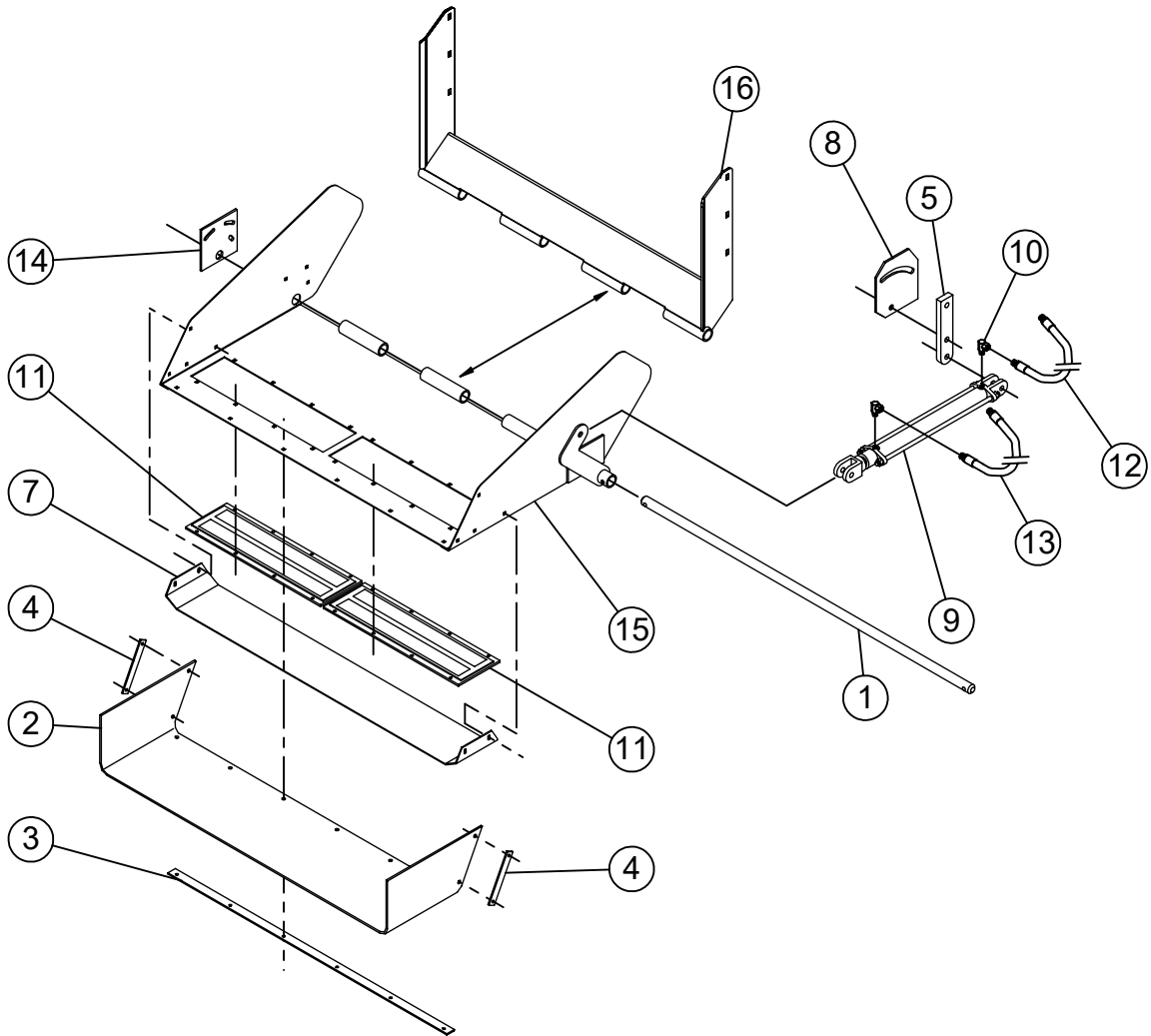

REF #	PART #	DESCRIPTION	QTY.
1	182238	SPOUT HINGE SHAFT	1
2	183145	SPOUT RUBBER	1
3	183152	BACK-UP ANGLE 47"	1
4	183160	BACK-UP STRAP	2
5	185896	SPOUT CYLINDER BAR	1
7	189079	SPOUT MAGNET GUARD (Used on 24" Spout)	1
	190865	SPOUT MAGNET GUARD (Used on 14" Spout)	1
8	189666	SPOUT CYLINDER BRACKET	1
9	364040	HYDRAULIC CYLINDER 1 1/2" x 16"	1
10	368011	HYD. ADAPTER 1/4"MP x 1/4" FPSW 90 1/16" ORFICE	2
11	375005	AM 2200 ARCO MAGNET	2
12	781066	HYD. HOSE 3/8" x 60" (3/8"MP x 1/4"MP)	1
13	781069	HYD HOSE 3/8" x 76" (3/8"MP x 1/4"MP)	1
14	872237	SPOUT HINGE ADJUSTMENT WELDMENT	1
15	872284	24" SPOUT WELDMENT (Shown)	1
	872283	14" SPOUT WELDMENT (Not Shown)	1
16	873261	SPOUT HINGE WELDMENT	1

620-16 & 620-16XD DISCHARGE DOOR ASSEMBLY

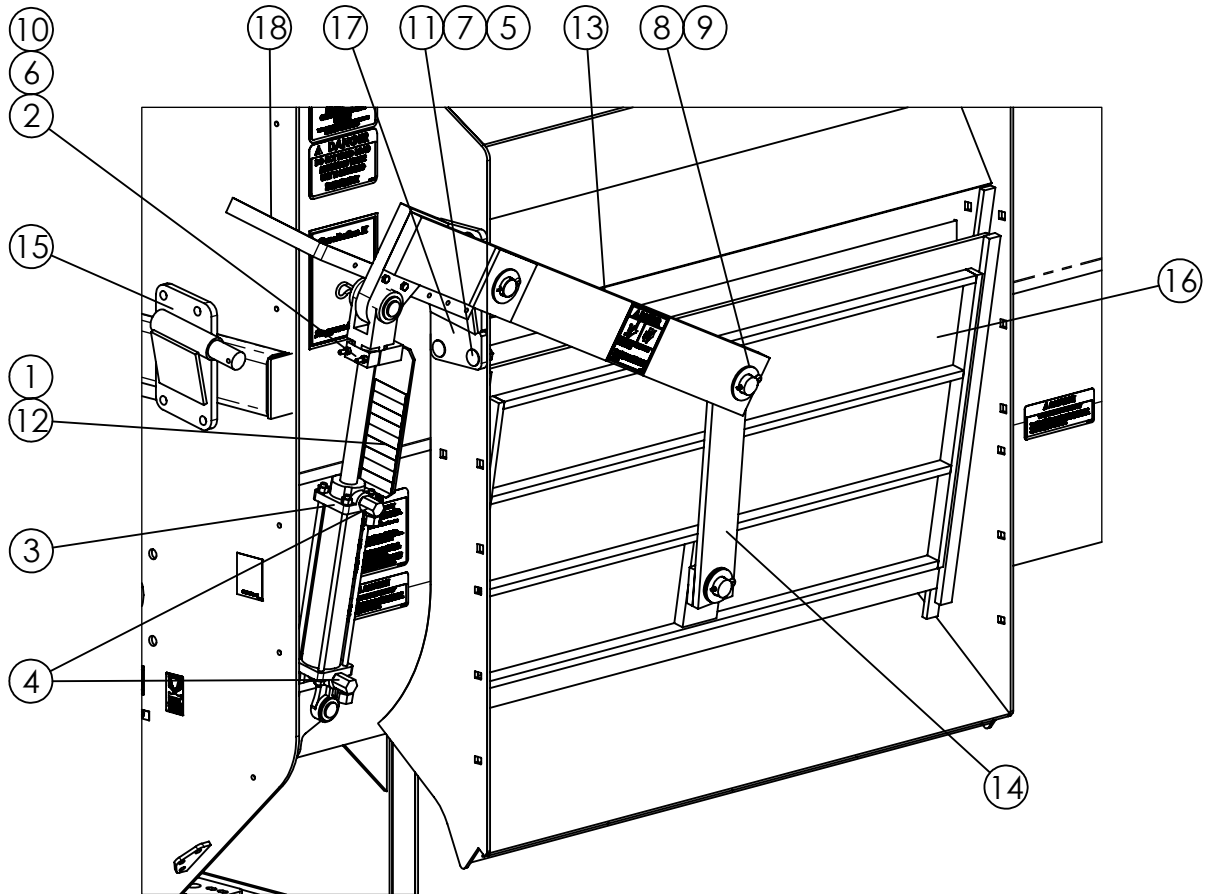

ITEM #	PART #	DESCRIPTION	QTY.
1	184259	DOOR CYL MARKER PLATE 10"	1
2	184267	CLAMP, DOOR CYLINDER MARKER 3"	1
3	364055	HYDRAULIC CYLINDER ASSY 2" x 8"	1
4	368007	HYDRAULIC ADAPTER 3/8"MP x 3/8"FPX 90° .109 orifice	2
5	400208	HEX NUT 1/2"-13 #5 PLTD	4
6	401104	HEX NUT, NYLOC 1/4"-20 #5 PLTD	2
7	402008	SPRING LOCK WASHER 1/2" PLTD	4
8	402518	1-1/8" SAE Flat Washer Pltd	4
9	404000	COTTER PIN 1/4" x 1 1/2"	3
10	405616	HHCS 1/4"-20 x 4" #5 PLTD	2
11	407102	CHCS 1/2"-13 x 1-1/2" #5 PLTD	4
12	440850	DECAL, DOOR INDICATOR 7" x 3" (Used with Truck Unit)	1
13	872247	37 1/2" STRT DOOR LEVER ARM WA	1
14	872248	STRAIGHT DOOR ARM W.A.	1
15	872258	PIVOT PIN PLATE WA (Used prior to the 620-16XD, only used on the 620-16)	1
16	872328	3/8" STRT DOOR PLT WA 24" x 45 3/4"	1
17	873142	PIVOT PIN PLATE WA (Used on 620-16XD)	1
18	187298	TRAILER DOOR MARKER (Used with Trailer Unit)	1

620-16XD CONVEYOR HYDRAULICS TRUCK MOUNT

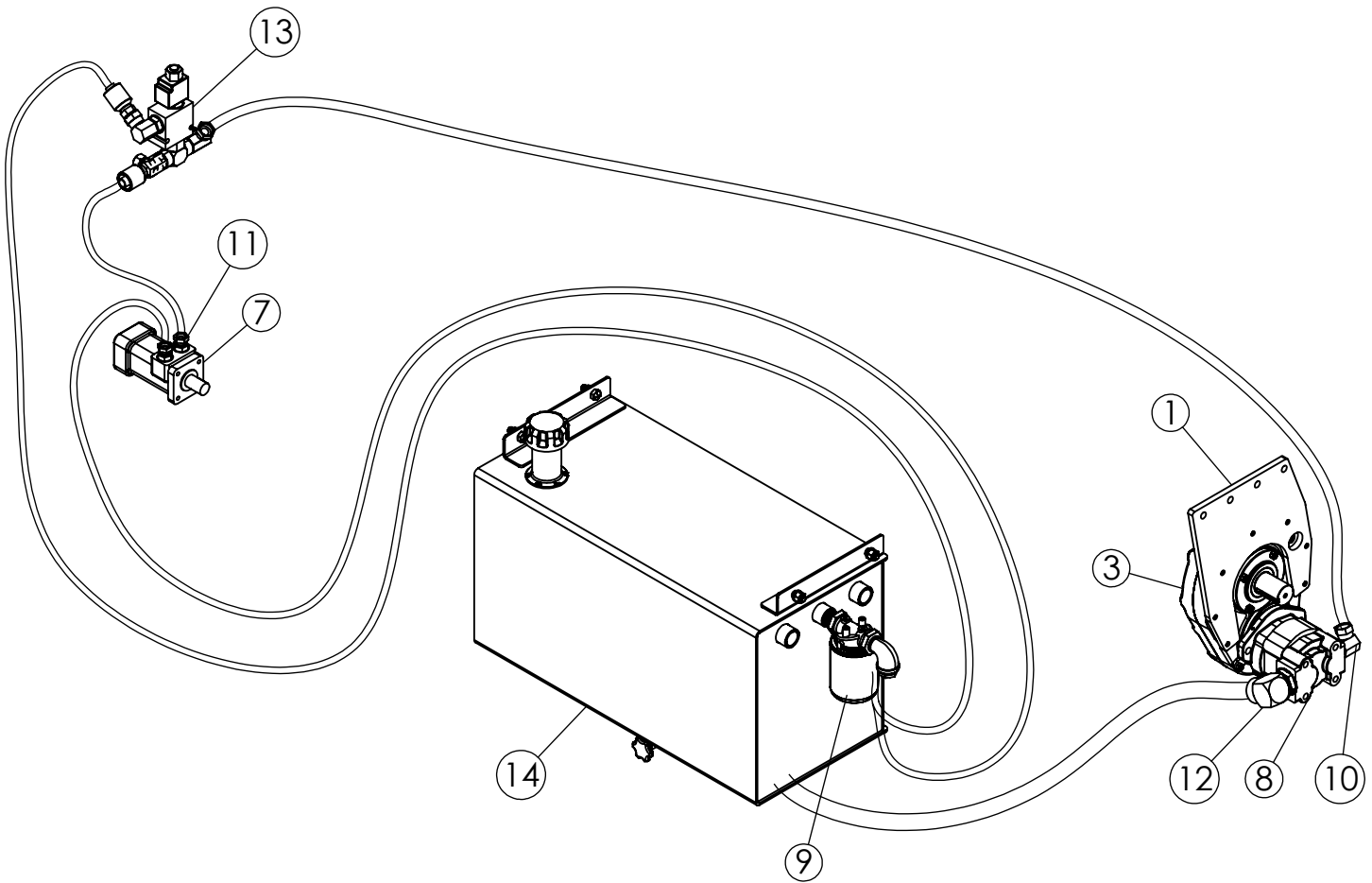

ITEM#	PART#	DESCRIPTION	QTY.
1	191974	GEAR BOX PLATE	1
2	192026	HUB CITY GEARBOX SPACER	1
3	344022	GEARBOX 2-1 HUB CITY 200	1
4	344207	GB INPUT SHAFT, PUMP MOUNT	1
5	344208	CLOSED END CAP HUB CITY	1
6	344209	GEARBOX SEAL 1-3/4" CR 18039	1
7	360009	10.0 CU IN. HYDRAULIC MOTOR	1
8	362024	GEAR PUMP CW	1
9	362441	FILTER ELEMENT VE-10 - 1"	1
10	368057	SWIVEL, 90° 1-1/16"MOR x 3/4"FPS	1
11	368118	HYD ADAPTER 7/8MORB x 1/2FP SWIVEL	2
12	368420	ELBOW, 1-5/8MOR x 1-1/4FP 90°	1
13	760013	DUMP VALVE ASSEMBLY	1
14	781167	FEEDER/VERTICAL HYDRAULIC RESERVOIR ASSEMBLY	1

620-16XD 48" WIDE CONVEYOR MOUNT KIT TRAILER MOUNT

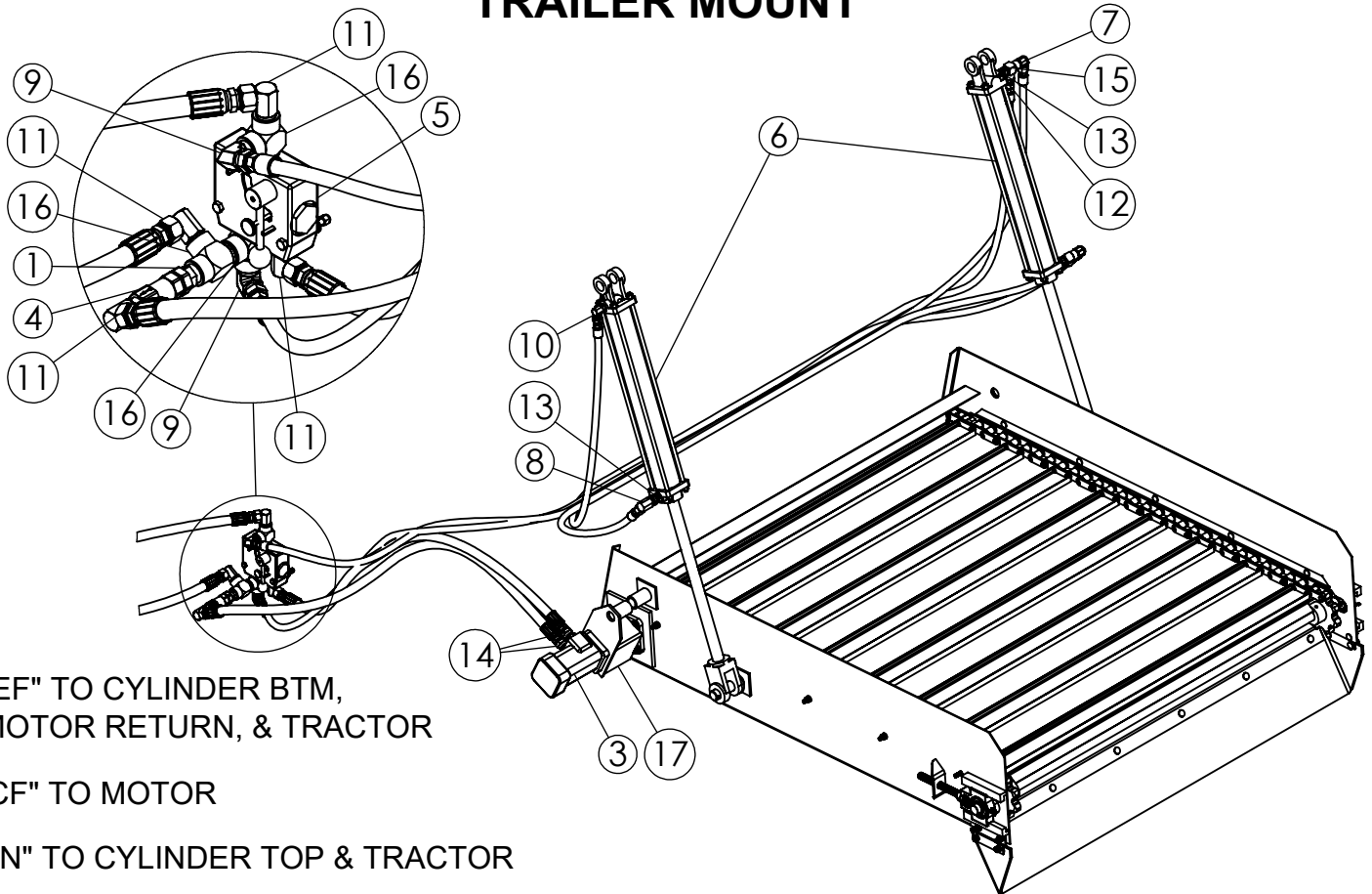

"EF" TO CYLINDER BTM,
MOTOR RETURN, & TRACTOR

"CF" TO MOTOR

"IN" TO CYLINDER TOP & TRACTOR

ITEM#	PART#	DESCRIPTION	QTY.
1	310805	HEX PIPE NIPPLE, 1/2"	1
2	332654	1"ID x 2" OD x 3" LTB COUPLING	1
3	360009	10.0 CU IN. HYDRAULIC MOTOR	1
4	362240	CHECK VALVE, 5 PSI (1/2FP x 1/2FP)	1
5	362283	VALVE PRINCE HYD. FLOW DIVIDER	1
6	364060	HYDRAULIC CYLINDER 2" x 16" 26-1/4" CC	2
7	368007	HYD ADAPTER 3/8MP x 3/8FPX 90° .109 ORIFICE	2
8	368020	SWIVEL 90° 3/8MP x 3/8FP	1
9	368028	SWIVEL 90° 1/2MP x 3/8FP	2
10	368030	SWIVEL 90° 9/16MOR x 3/8FP	1
11	368031	SWIVEL 90° 1/2MP x 1/2FP	4
12	368110	HYD ADAPTER 3/8MP x 3/8FP SWIVEL	2
13	368115	HYD ADAPTER 9/16MOR x 3/8FP SWIVEL	3
14	368118	HYD ADAPTER 7/8MORB x 1/2FP SWIVEL	2
15	368606	STREET TEE 3/8MP x 3/8FP x 3/8FP	2
16	368608	STREET TEE 1/2MP x 1/2FP x 1/2FP	3
17	874071	CONVEYOR MOTOR PLATE W.A.	1

620-16XD CHAIN CONVEYOR

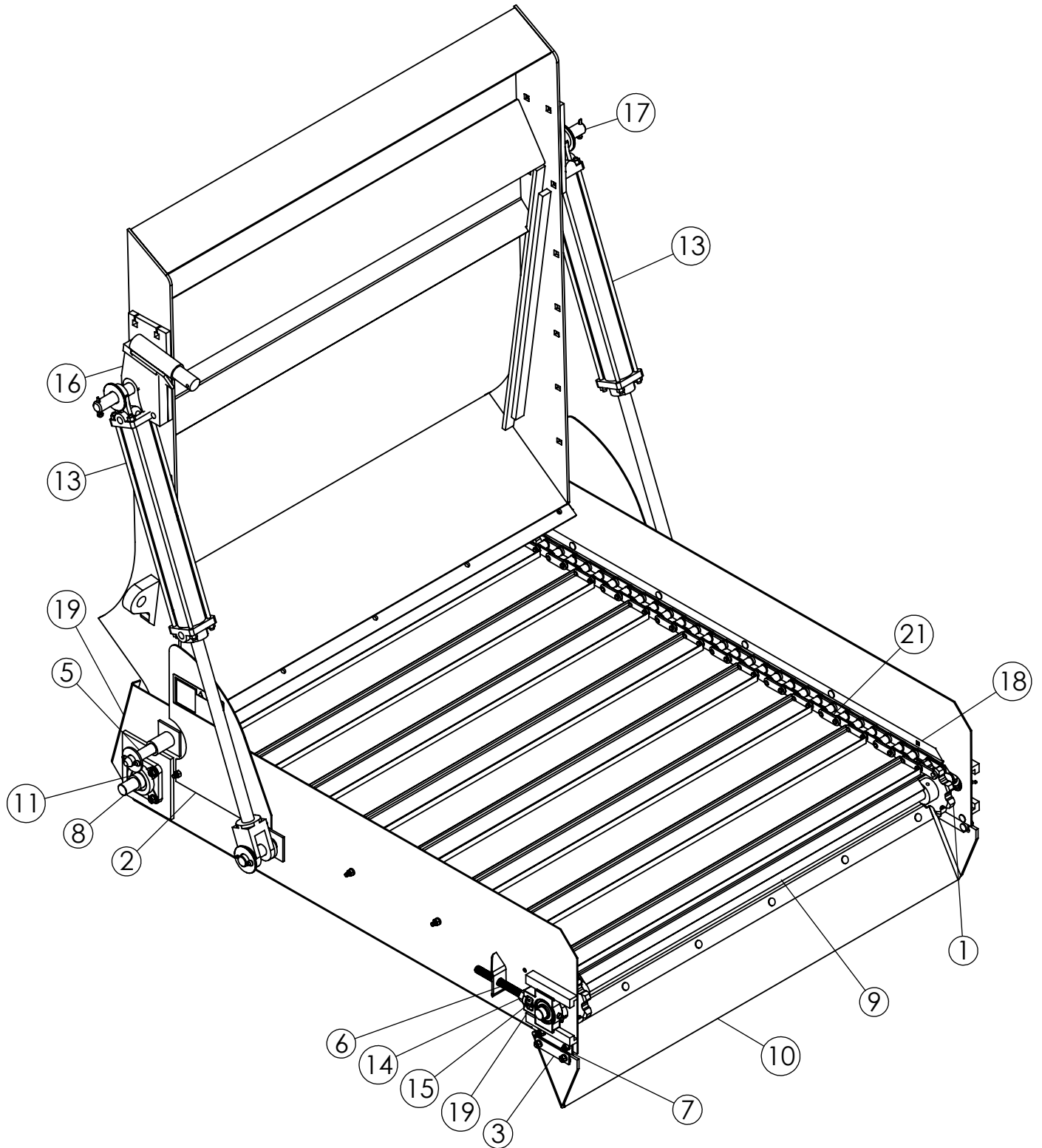

620-16XD CHAIN CONVEYOR

#781414.....48"W X 24"L CHAIN CONVEYOR ASSEMBLY

#781446.....48"W X 36"L CHAIN CONVEYOR ASSEMBLY

#781465.....48"W X 48"L CHAIN CONVEYOR ASSEMBLY

ITEM#	PART#	DESCRIPTION	QTY.
1	160025	SPROCKET C55, 8 TOOTH x 1" I.D.	4
2	188056	CONV SIDE SHIELD 14 1/16" x 12 1/8"	2
3	188304	CONVEYOR SPOUT RUBBER BAR - 4"	2
4	188384	CONVEYOR SPOUT RUBBER BAR - 45 3/4"	1
5	188387	DOOR HINGE SHAFT	1
6	188390	TAKE UP BOLT x 7"	2
7	188418	SPOUT RUBBER SIDE BAR - 4"	2
8	188427	48" CONV DRIVE SHAFT - 52"	1
9	188428	48" CONV IDLER SHAFT - 51"	1
10	188432	48" CONVEYOR SPOUT RUBBER - 56 3/4"	1
11	340316	FLANGE BEARING 1" 4 BOLT RCJC	2
12	341323	TAKE-UP BEARING 1"	2
13	364060	HYDRAULIC CYLINDER 2" x 16" 26-1/4" CC	2
14	400210	HEX NUT 5/8"-11 #5 PLTD	2
15	400810	HEX UNILOCK NUT 5/8"-11	2
16	873214	PIVOT PIN PLATE WA (XD)	1
17	873215	LIFT CYLINDER PLATE WA (XD)	1
18	874122	48"W X 48"L CONVEYOR PAN WA	1
	874004	48"W X 36"L CONVEYOR PAN WA	
	874126	48"W X 24"L CONVEYOR PAN WA	
19	874124	48" W x 48"L CONVEYOR WA	1
	874136	48" W x 36"L CONVEYOR WA	
	874128	48" W x 24"L CONVEYOR WA	
20	874149	CONVEYOR HINGE WA	1
21	874153	CONVEYOR CHAIN WA x 67 P 48W x 48L	1
	874154	CONVEYOR CHAIN WA x 53 P 48W x 36L	
	874127	CONVEYOR CHAIN WA x 38 P 48W x 24L	

620-16XD STAGGERED ROTOR

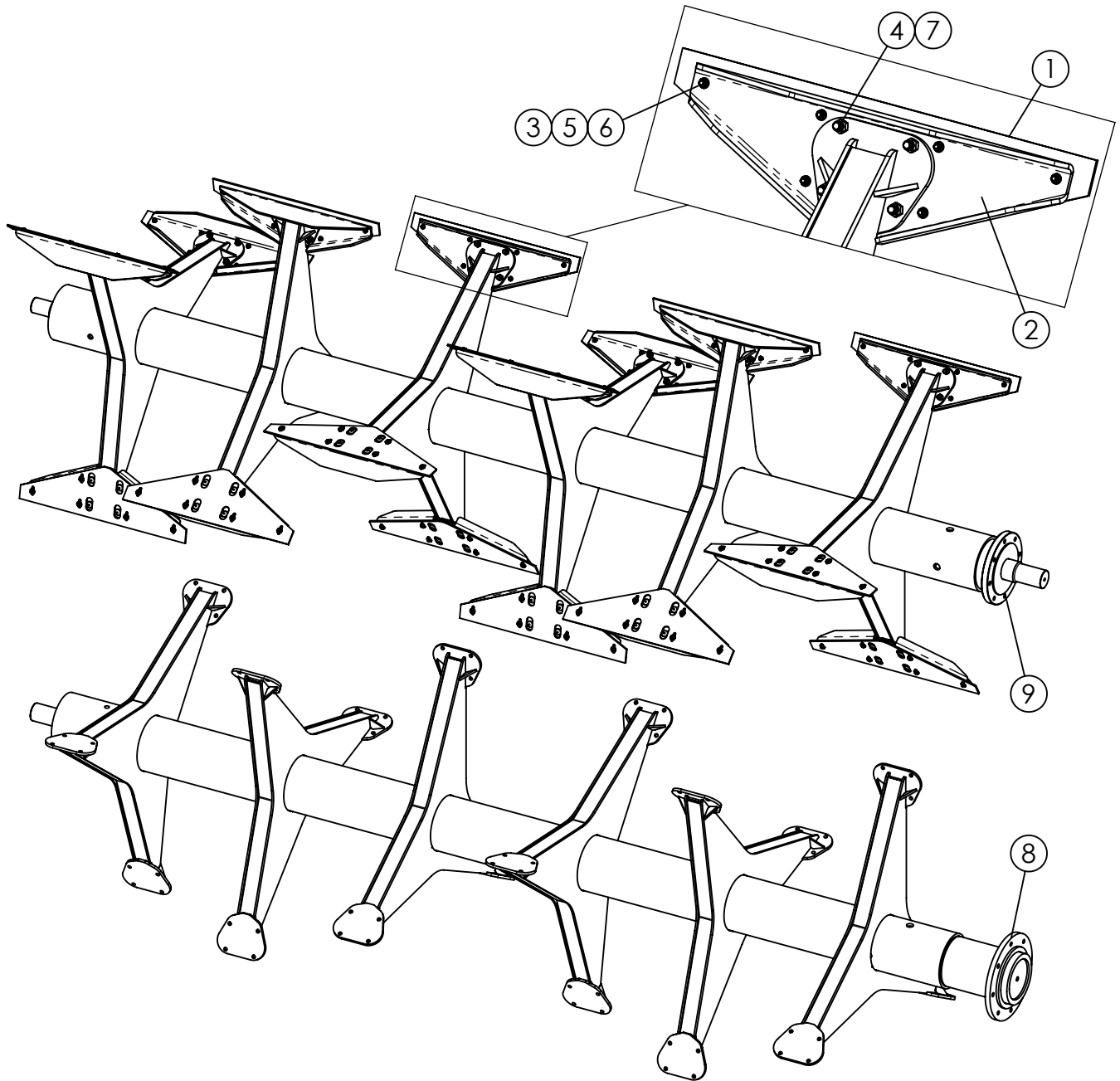

ITEM #	PART #	DESCRIPTION	QTY
1	190339P	PLASTIC WIPER	18
2	190770	WIPER CHANNEL 5/8 BOLTS	18
3	401106	HEX NUT, 3/8-16 NYLOCK #5	108
4	400910	HEX CROWN LOCNUT 5/8"-11 #9 PLTD	72
5	402806	FLAT WASHER 3/8" #9 BOWMALLOY	108
6	406906	HHCS 3/8"-16 x 1-1/4" #9 BOWMALLOY	108
7	407130	CHCS 5/8"-11 x 2" #8 PLTD	72
8	872998	620-16XD STGRD ROTOR - 9-3/4" NYLATRON BEARING	1
9	873132	620-16 STAG ROTOR WA- ROLLER BEARING	1

620-16XD 3-ARM ROTOR ASSEMBLY

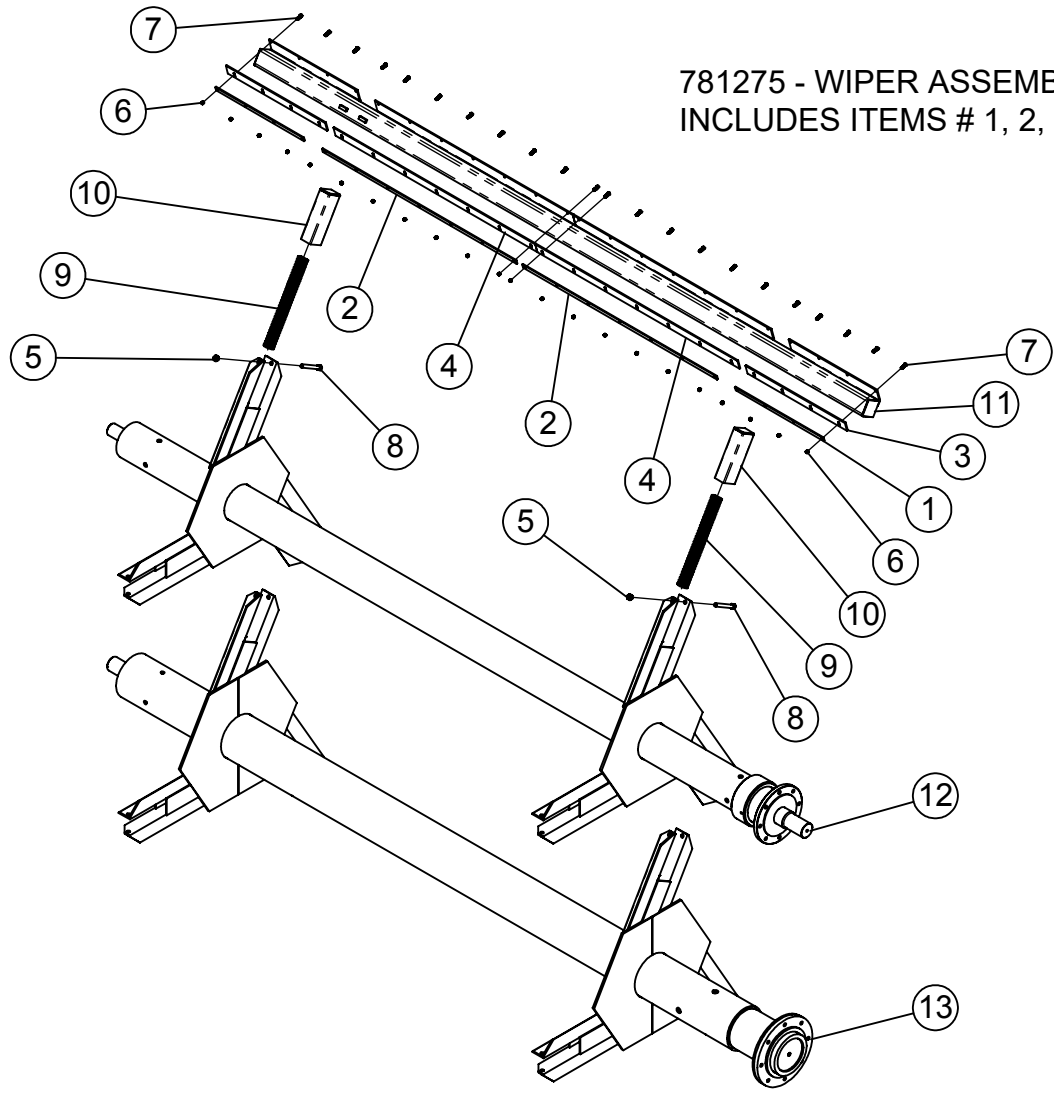

781275 - WIPER ASSEMBLY,
INCLUDES ITEMS # 1, 2, 3, 4, 6, 7, & 11

ITEM #	PART #	DESCRIPTION	QTY.
1	189141	END WIPER STRAP	2
2	189142	CENTER WIPER STRAP	2
3	189143	END PLASTIC WIPER 2-1/2" x 30-3/4"	2
4	189144	CENTER PLASTIC WIPER 2-1/2" x 62-1/2"	2
5	400912	HEX CROWN LOCK NUT 3/4"-10 #5 PLTD	2
6	401106	HEX NUT, 3/8"-16 NYLOC #5 PLTD	22
7	405654	HHCS 3/8"-16 x 1-1/4" #5 PLTD	22
8	406489	HHCS 3/4"-10 x 6" #8 PLTD	2
9	410005	SPRING, COMPRESSION, 2 1/2" x 24" x .41"	2
10	850007	ROTOR SPRING COVER WA	2
11	872361	ROTOR SQUARE WIPER WA	1
12	872643	620-16 3-ARM ROTOR WA - ROLLER BEARING	1
13	873188	620-16XD 3-ARM ROTOR WA - NYLATRON BEARING	1

620-16XD 5-ARM ROTOR ASSEMBLY

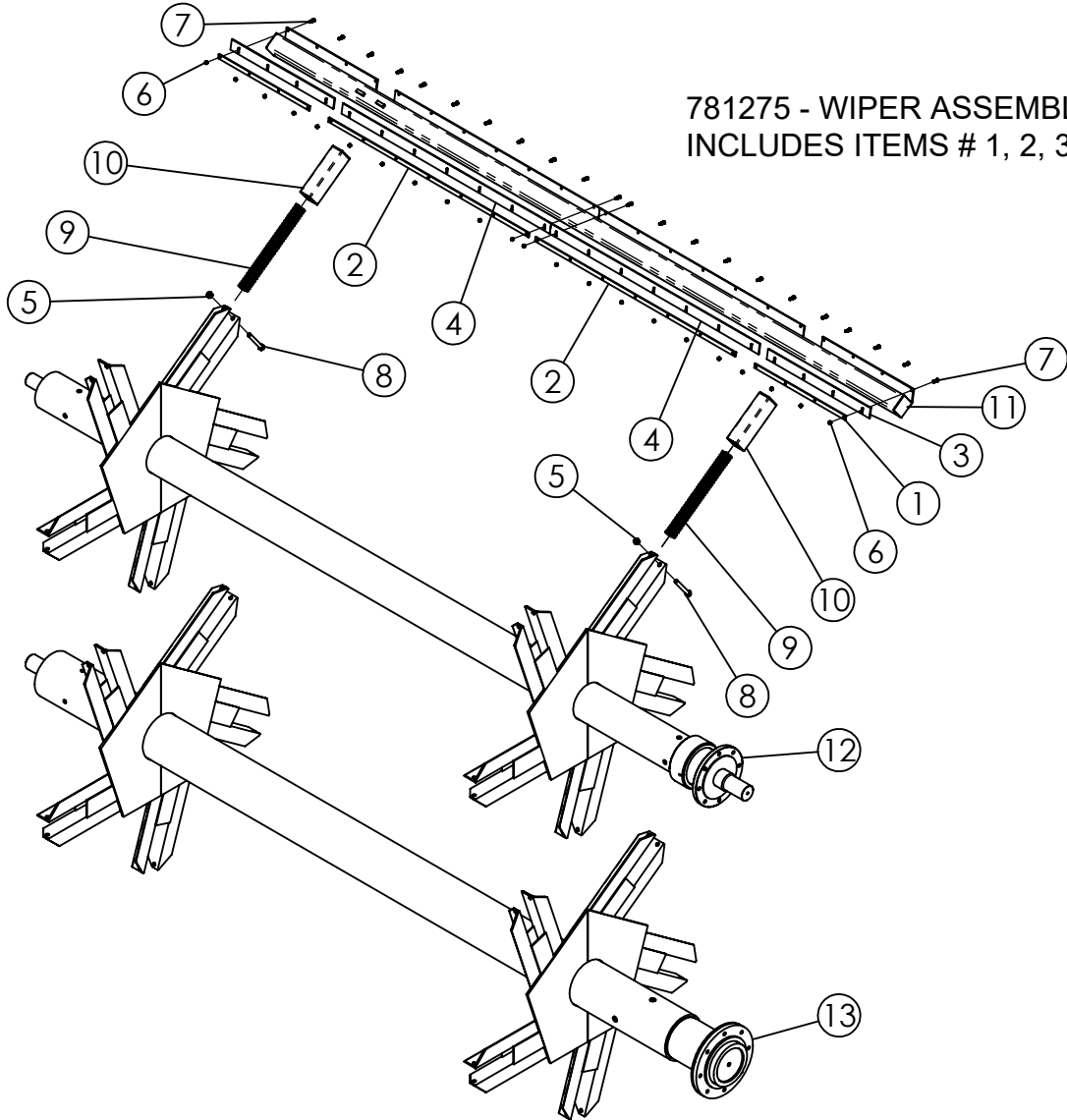

781275 - WIPER ASSEMBLY,
INCLUDES ITEMS # 1, 2, 3, 4, 6, 7, & 11

ITEM #	PART #	DESCRIPTION	QTY.
1	189141	END WIPER STRAP	2
2	189142	CENTER WIPER STRAP	2
3	189143	END PLASTIC WIPER 2-1/2" x 30-3/4"	2
4	189144	CENTER PLASTIC WIPER 2-1/2" x 62-1/2"	2
5	400912	HEX CROWN LOCK NUT 3/4"-10 #5 PLTD	2
6	401106	HEX NUT, 3/8"-16 NYLOC #5 PLTD	22
7	405654	HHCS 3/8"-16 x 1-1/4" #5 PLTD	22
8	406489	HHCS 3/4"-10 x 6" #8 PLTD	2
9	410005	SPRING, COMPRESSION, 2 1/2" x 24" x .41"	2
10	850007	ROTOR SPRING COVER WA	2
11	872361	ROTOR SQUARE WIPER WA	1
12	872634	620-16 5-ARM ROTOR WA - ROLLER BEARING	1
13	873139	620-16XD 5-ARM ROTOR WA - Nylatron Bearing	1
	873139RH	620-16XD 5-ARM ROTOR WA - Nylatron BRG, RIGHT HAND	1

620-16XD 6-ARM ROTOR ASSEMBLY

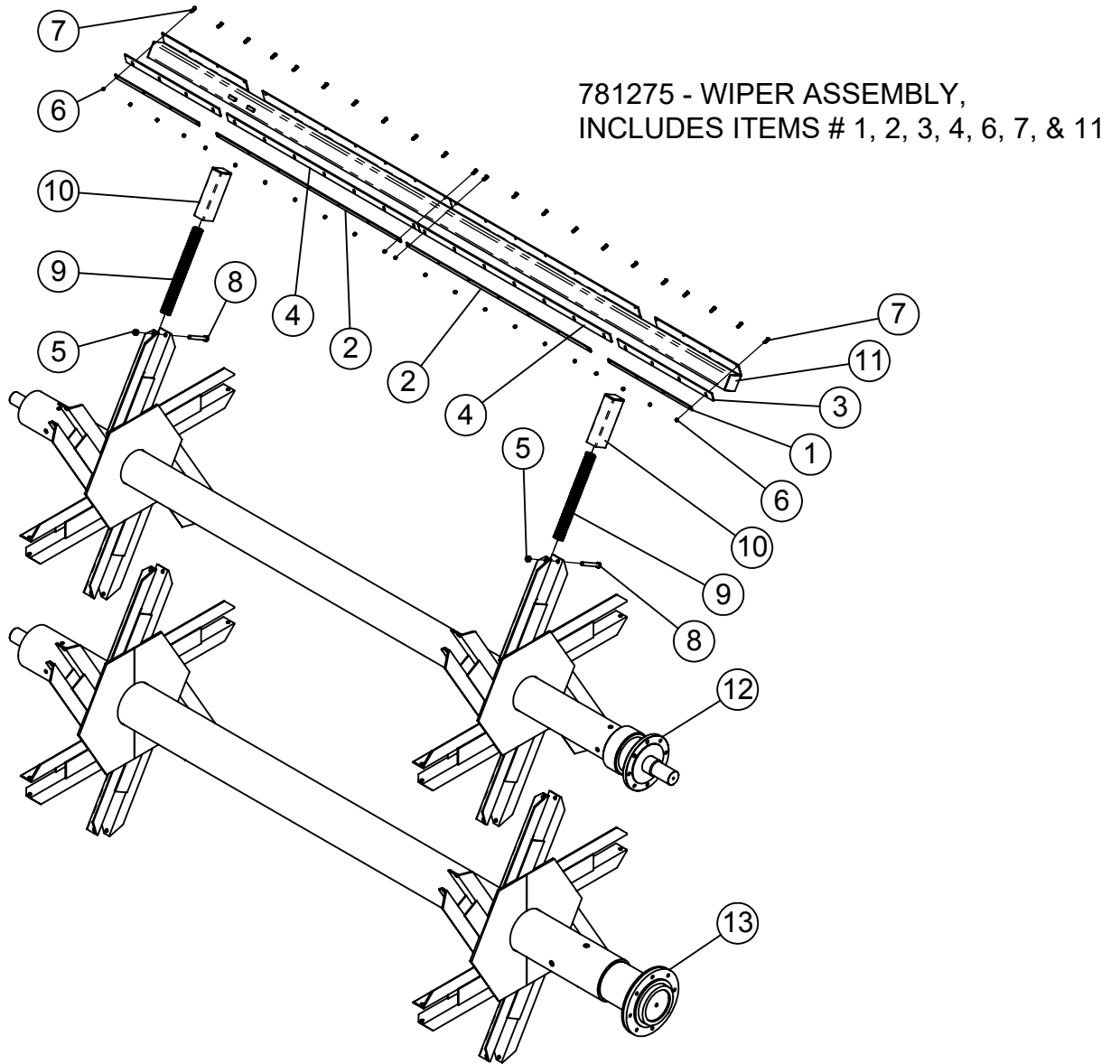

ITEM #	PART #	DESCRIPTION	QTY.
1	189141	END WIPER STRAP	2
2	189142	CENTER WIPER STRAP	2
3	189143	END PLASTIC WIPER 2-1/2" x 30-3/4"	2
4	189144	CENTER PLASTIC WIPER 2-1/2" x 62-1/2"	2
5	400912	HEX CROWN LOCK NUT 3/4"-10 #5 PLTD	2
6	401106	HEX NUT, 3/8"-16 NYLOC #5 PLTD	22
7	405654	HHCS 3/8"-16 x 1-1/4" #5 PLTD	22
8	406489	HHCS 3/4"-10 x 6" #8 PLTD	2
9	410005	SPRING, COMPRESSION, 2 1/2" x 24" x .41"	2
10	850007	ROTOR SPRING COVER WA	2
11	872361	ROTOR SQUARE WIPER WA	1
12	872641	620-16 6-ARM ROTOR WA - ROLLER BEARING	1
13	873189	620-16XD 6-ARM ROTOR WA - Nylatron Bearing	1

620-16XD TOP AUGER

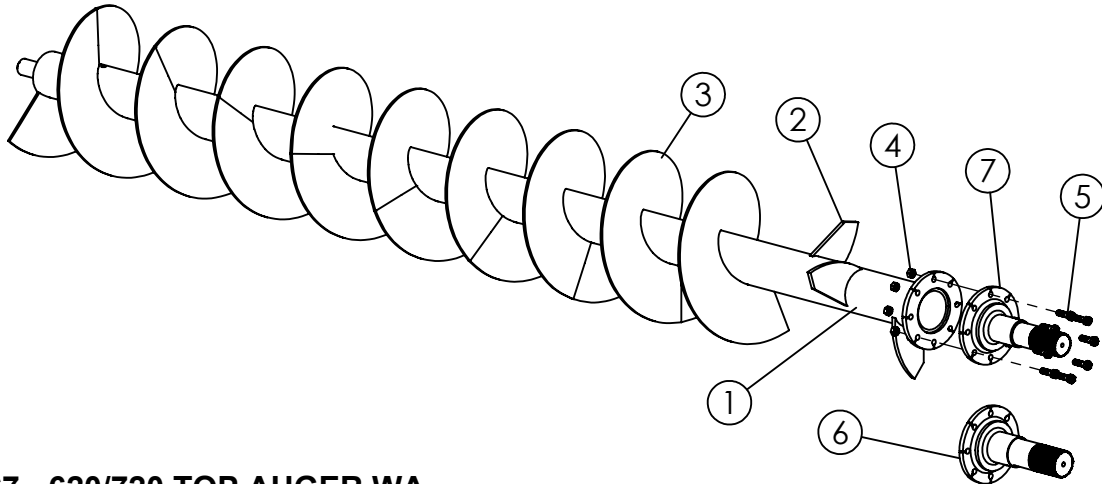

#872367 - 620/720 TOP AUGER WA

ITEM #	PART #	DESCRIPTION	QTY.
1	872367	620/720 TOP AUGER WA	1
2	185708	24" TOP AUGER PADDLE - 6" x 9 5/8"	3
3	382424	FLIGHT 24"OD x 6 5/8"ID x 3/8" RH 2/3 PITCH	9
4	400912	HEX CROWN LOCK NUT 3/4"-10 #5 PLTD	8
5	406481	HEX BOLT, 3/4-10 x 2-1/2 #8 PITD HHCS	8
6	872650	HEAVY TOP AUGER SHAFT FLANGE WA 620 4"	1
7	872625	620 TOP AUGER SHAFT FLANGE WA 3-1/2"	1

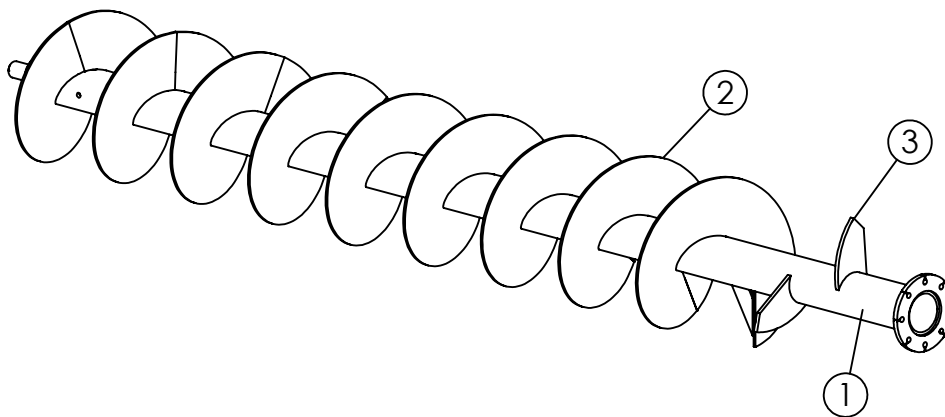

#872367RH - 620/720 RIGHT HAND DISCHARGE TOP AUGER WA

ITEM #	PART #	DESCRIPTION	QTY.
1	872367RH	620/720 RIGHT HAND DISCHARGE TOP AUGER WA	1
2	382425	FLIGHT 24"OD x 6-5/8"ID x 3/8" LH 2/3 PITCH	9
3	185708	24" TOP AUGER PADDLE - 6" x 9 5/8"	3

620-16XD TOP AUGER

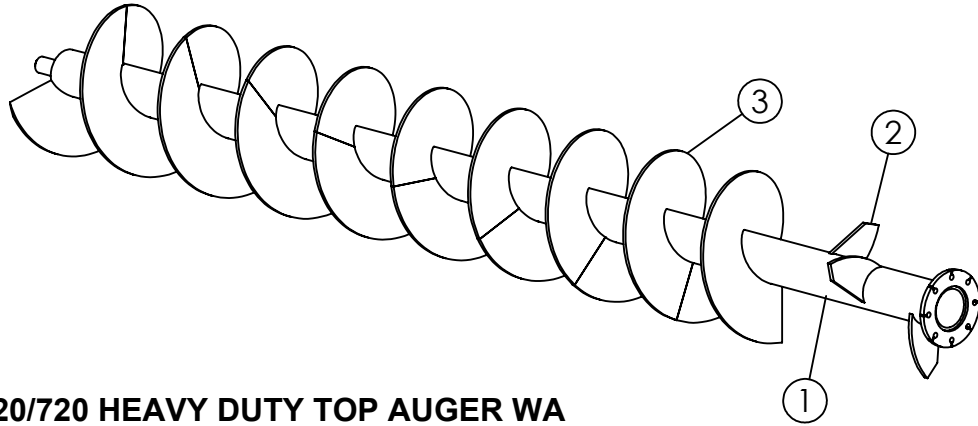

#872736 - 620/720 HEAVY DUTY TOP AUGER WA

ITEM #	PART #	DESCRIPTION	QTY.
1	872736	620/720 HEAVY DUTY TOP AUGER WA	1
2	185708	24" TOP AUGER PADDLE - 6" x 9 5/8"	3
3	382430	FLIGHT 24"OD x 6-5/8"ID x 1/2" RH 2/3 PITCH	9

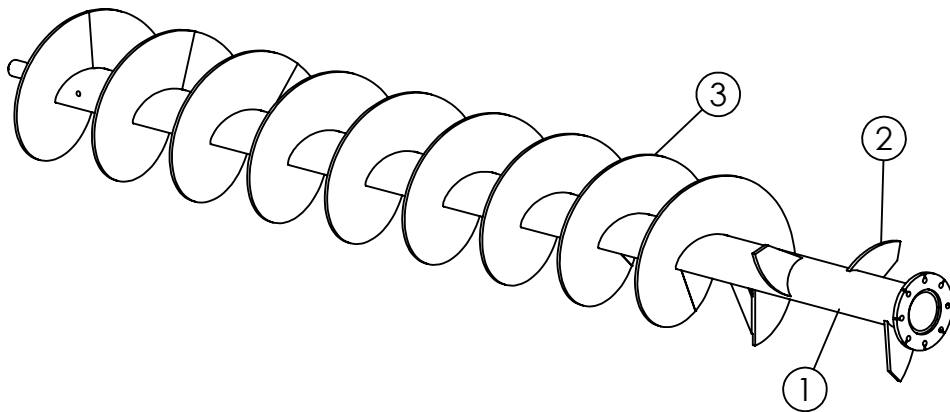

#872736RH - 620/720 HEAVY DUTY RIGHT HAND DISCHARGE TOP AUGER WA

ITEM #	PART #	DESCRIPTION	QTY.
1	872736RH	620/720 RIGHT HAND HEAVY DUTY TOP AUGER WA	1
2	185708	24" TOP AUGER PADDLE - 6" x 9 5/8"	3
3	382431	FLIGHT 24"OD x 6-5/8"ID x 1/2" LH 2/3 PITCH	9

620-16XD TOP AUGER

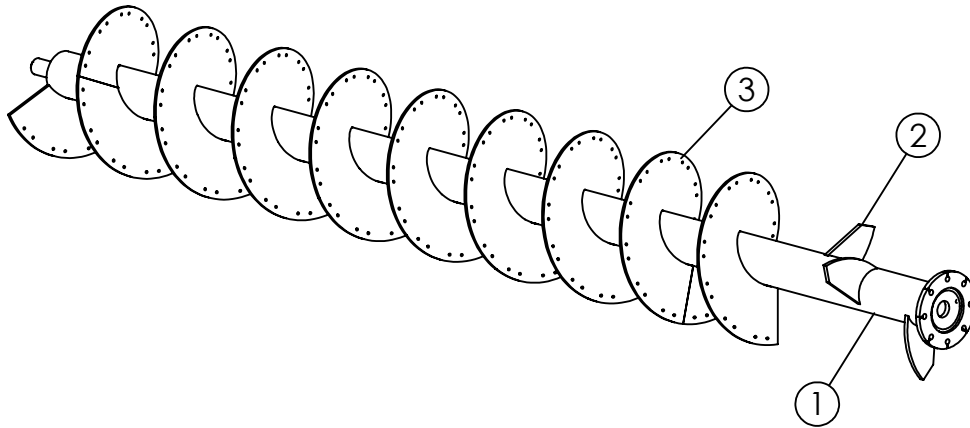

#872691 - 620/720 TOP AUGER WA WITH KNIFE HOLES

ITEM #	PART #	DESCRIPTION	QTY.
1	872691	620/720 TOP AUGER WA with KNIFE HOLES	1
2	185708	24" TOP AUGER PADDLE - 6" x 9 5/8"	3
3	382428	FLIGHT 24"OD x 6-5/8"ID x 3/8" RH 16" PITCH	9

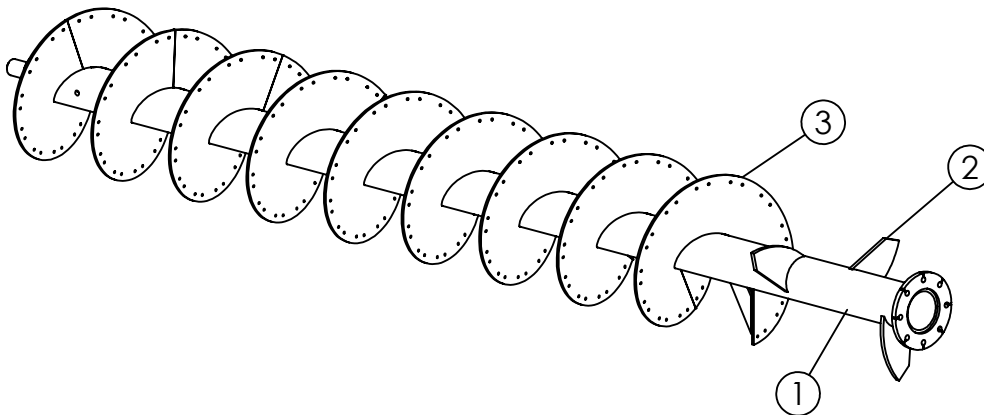

#872691RH - 620/720 RIGHT HAND DISCHARGE TOP AUGER WA WITH KNIFE HOLES

ITEM #	PART #	DESCRIPTION	QTY.
1	872691RH	620/720 RIGHT HAND TOP AUGER WA with KNIFE HOLES	1
2	185708	24" TOP AUGER PADDLE - 6" x 9 5/8"	3
3	382429	24" OD x 6 5/8" ID x 3/8" x 16" PITCH LH FLIGHT	9

620-16XD TOP AUGER

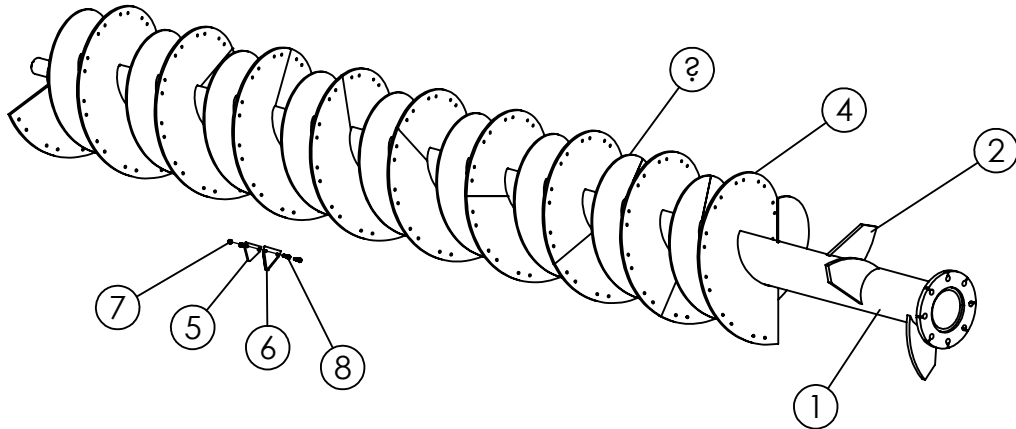

#872627 - 620/720 DOUBLE FLIGHT TOP AUGER WA

ITEM #	PART #	DESCRIPTION	QTY.
1	872627	620/720 DOUBLE SLIGHT TOP AUGER WA	1
2	185708	24" TOP AUGER PADDLE - 6" x 9 5/8"	3
3	382045	FLIGHT 20"OD x 6 5/8"ID x 1/4" x 16"P RH	9
4	382428	FLIGHT 24"OD x 6-5/8"ID x 3/8" RH 2/3 PITCH	9
5	150223	KNIFE BACK UP PLATE	1
6	385002	SICKLE SECTION, HARD SURFACED, 5/16"	1
7	401105	HEX NUT, 5/16"-18 NYLOC #5 PLTD	2
8	405629	HHCS 5/16"-18 x 1-1/4" #5 PLTD	2

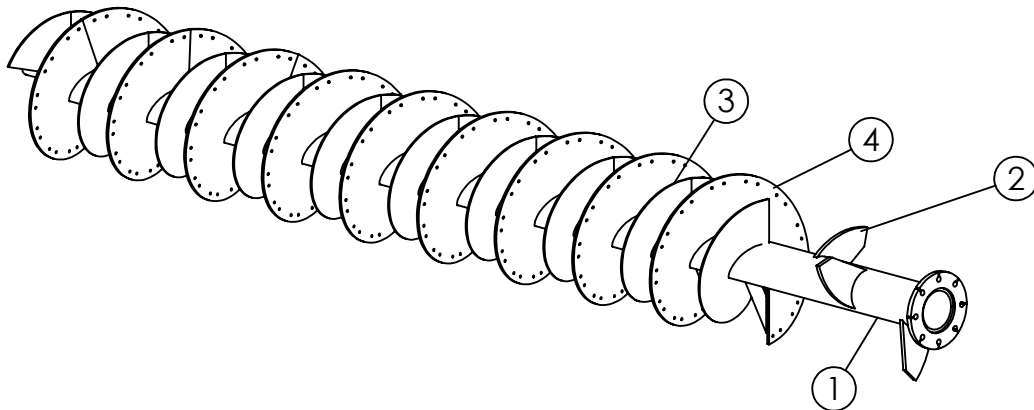

#872627RH - 620/720 RIGHT HAND DISCHARGE DOUBLE FLIGHT TOP AUGER WA

ITEM #	PART #	DESCRIPTION	QTY.
1	872627RH	620/720 DOUBLE FLIGHT TOP AUGER WA	1
2	185708	24" TOP AUGER PADDLE - 6" x 9 5/8"	3
3	382053	20" OD x 6-5/8" ID x 1/4" x 16" PITCH LH FLIGHT	10
4	382429	24" OD x 6 5/8" ID x 3/8" x 16" PITCH LH FLIGHT	9

620-16XD BOTTOM AUGERS

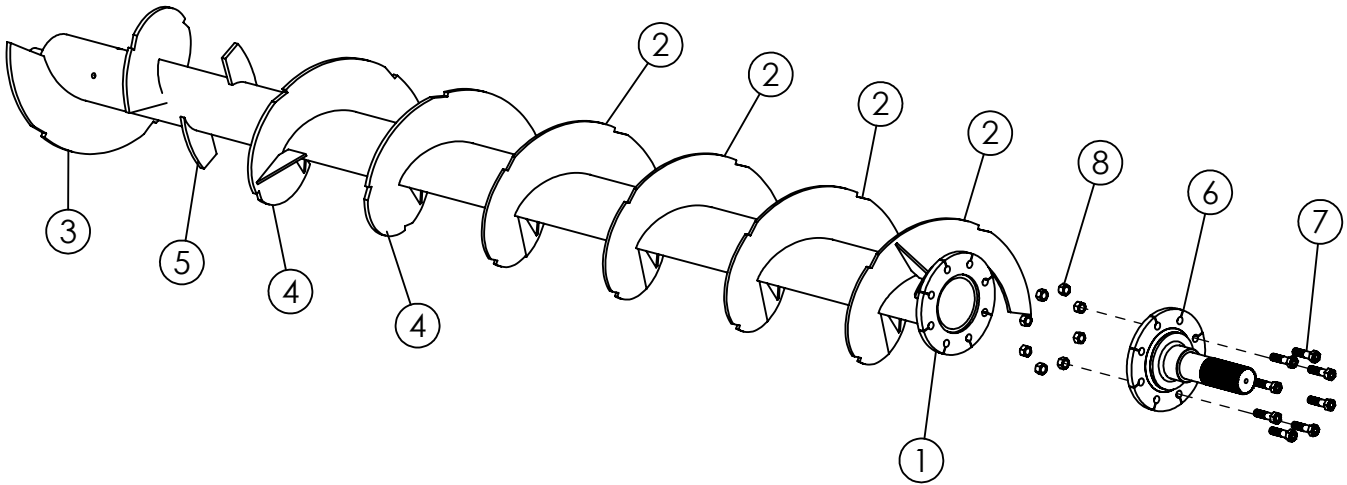

#872728 - 620-16 BOTTOM AUGER WA

ITEM #	PART #	DESCRIPTION	QTY.
1	872728	620 BOTTOM AUGER WA, 3/4" & 1/2"	1
2	382427	24" OD x 8 5/8" ID x 1/2" LH FULL PITCH	4
3	382454	24" OD x 8-5/8" ID x 3/4" RH FULL PITCH	1
4	382455	24" OD x 8 5/8" ID x 3/4" LH FULL PITCH	2
5	189269	24" AUGER KICKER 4-7/16" x 9-7/16"	2
6	872626	BOTTOM AUGER SHAFT FLANGE WA, 620	1
7	406528	HHCS 1"-8 x 3-3/4" #8 PLTD	8
8	400916	HEX CROWN LOCKNUT, 1"-8 #5 PLTD	8

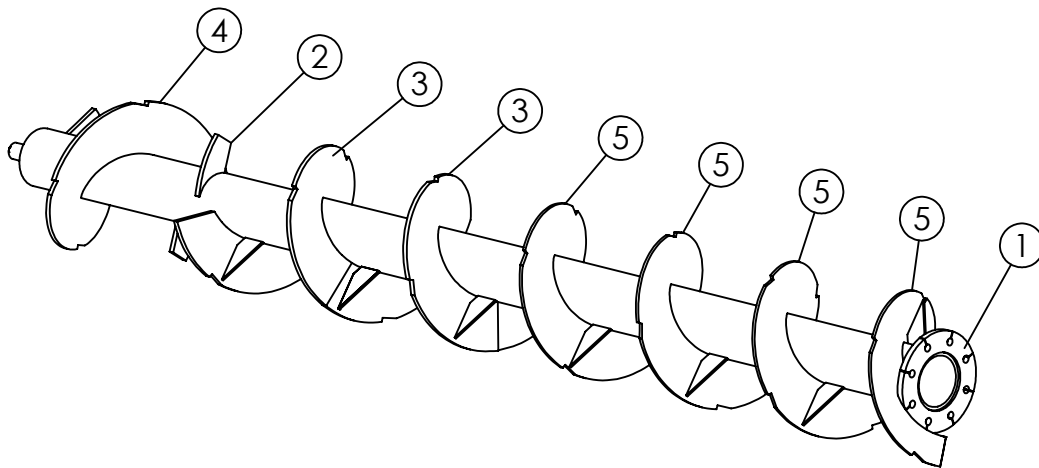

#872728RH - 620-16 RIGHT HAND DISCHARGE3 BOTTOM AUGER WA

ITEM #	PART #	DESCRIPTION	QTY.
1	872728RH	620-16 RIGHT HAND BOTTOM AUGER WA	1
2	189269	24" AUGER KICKER 4-7/16" x 9-7/16"	2
3	382454	24" OD x 8-5/8" ID x 3/4" RH FULL PITCH	2
4	382455	24" OD x 8 5/8" ID x 3/4" LH FULL PITCH	1
5	382426	24"OD x 8 5/8" ID x 1/2" RH FULL PITCH	4

620-16XD BOTTOM AUGERS

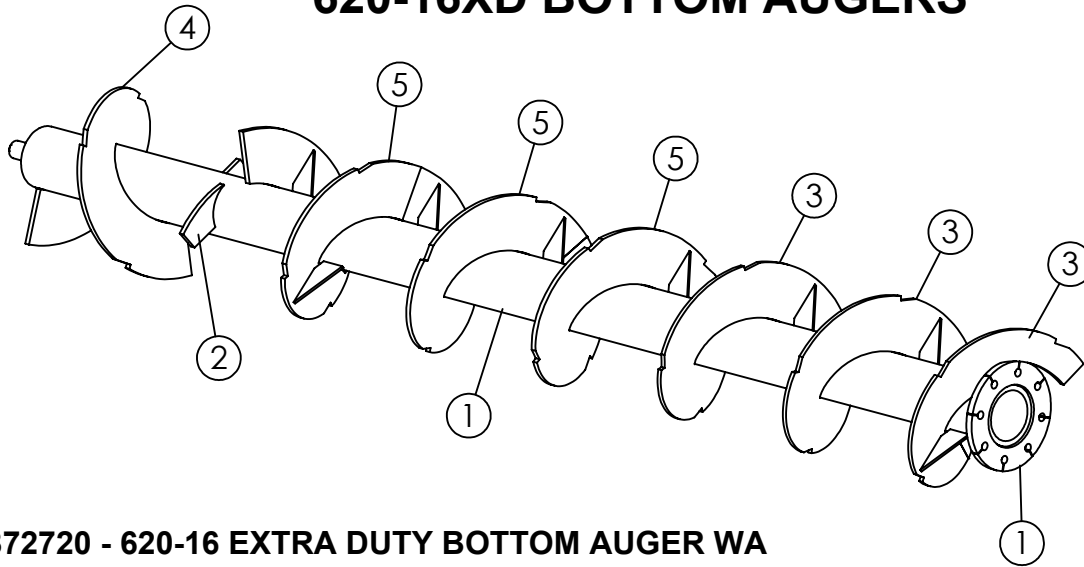

#872720 - 620-16 EXTRA DUTY BOTTOM AUGER WA

ITEM #	PART #	DESCRIPTION	QTY.
1	872720	620-16 LEFT HAND EXTRA DUTY BOTTOM AUGER WA	1
2	189269	24" AUGER KICKER 4-7/16" x 9-7/16"	2
3	382435	24" OD x 8 5/8" ID x 5/8" LH FULL PITCH	3
4	382454	24" OD x 8-5/8" ID x 3/4" RH FULL PITCH	1
5	382455	24" OD x 8 5/8" ID x 3/4" LH FULL PITCH	3

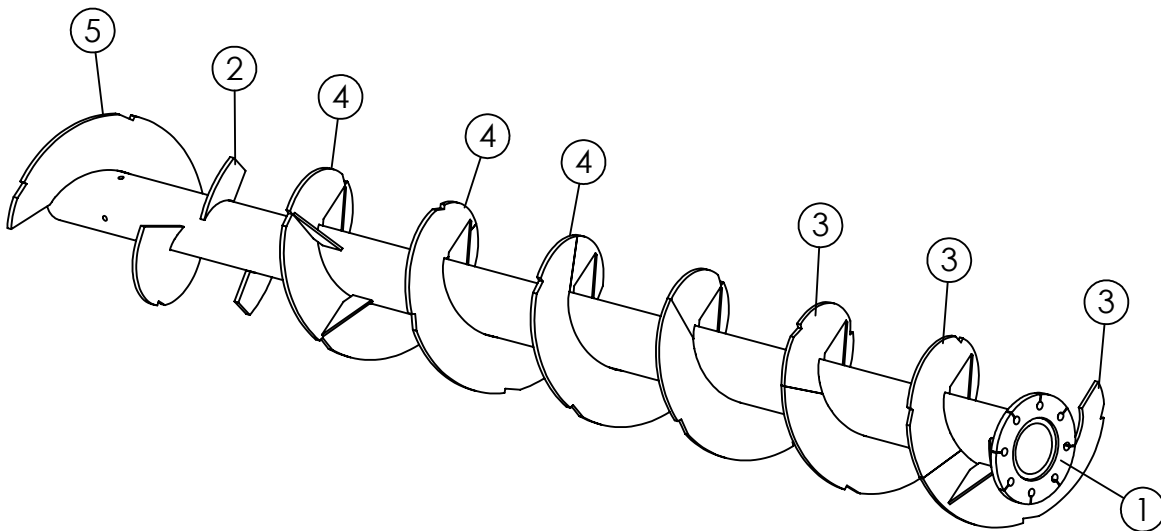

#872720RH - 620-16 RIGHT HAND DISCHARGE EXTRA DUTY BOTTOM AUGER WA

ITEM #	PART #	DESCRIPTION	QTY.
1	872720RH	620-16 RIGHT HAND EXTRA DUTY BOTTOM AUGER WA	1
2	189269	24" AUGER KICKER 4-7/16" x 9-7/16"	2
3	382434	24" OD x 8 5/8" ID x 5/8" RH FULL PITCH	3
4	382454	24" OD x 8-5/8" ID x 3/4" RH FULL PITCH	3
5	382455	24" OD x 8 5/8" ID x 3/4" LH FULL PITCH	1

620-16XD DRIVE ASSEMBLY CHAINS & TIGHTENERS

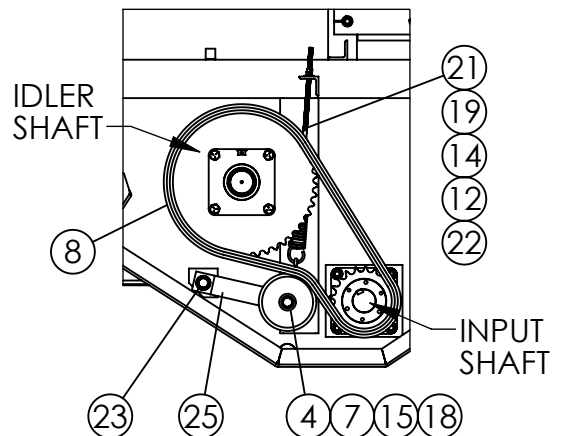
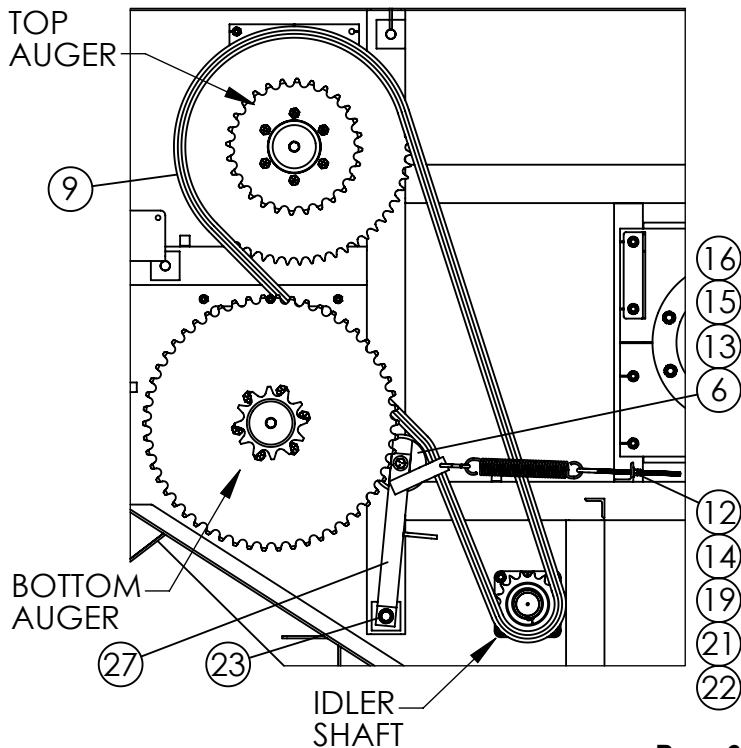
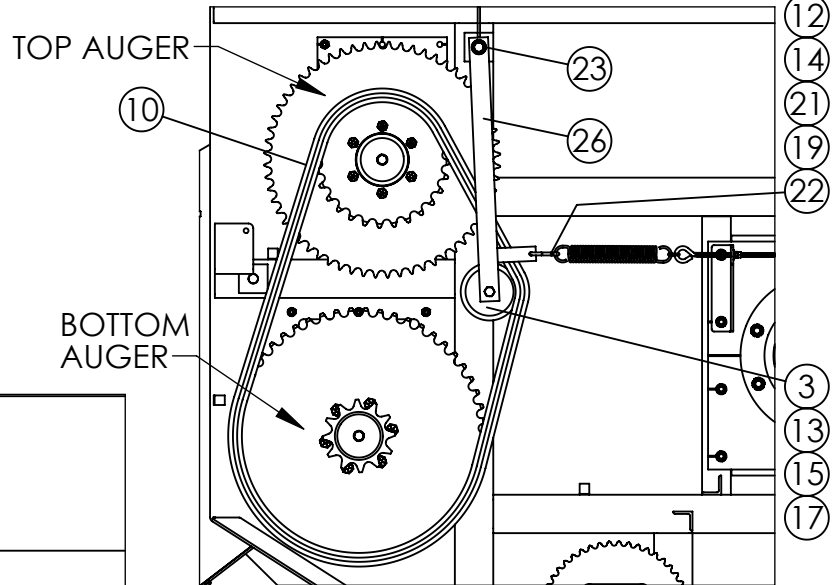
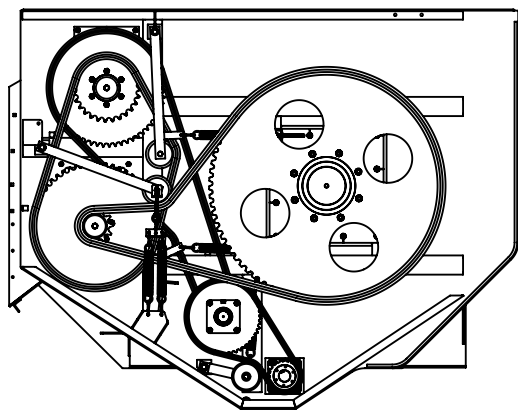
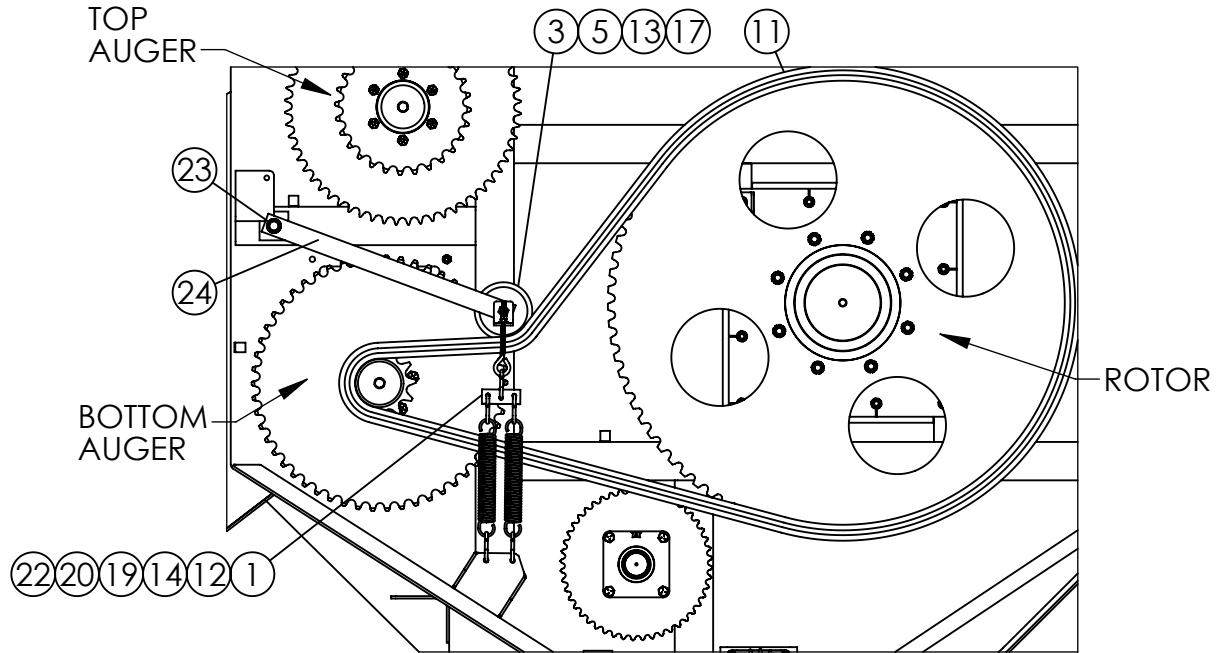

620-16XD DRIVE ASSEMBLY CHAINS & TIGHTENERS

ITEM #	PART #	DESCRIPTION	QTY.
1	185290	SPRING PULL BAR	1
2	185488	CHAIN-2/0 PASSING LINK	1
3	185652	IDLER BLOCK 6" OD, 120-140	2
4	187157	5/8" PULL TAB	1
5	190836	FORMED IDLER ANGLE	1
6	190889	IDLER BLOCK 6" OD, #80-100	1
7	190890	IDLER BLOCK 6" OD, #80-100, OFFSET	1
8	320870	RS80 ROLLER CHAIN x 70P (USED ON STANDARD DRIVE 1000 PTO TRAILER, TRUCK & STATIONARY)	1
	320872	RS80 ROLLER XCHAIN x 72P (540 PTO TRAILER)	1
9	321126	RS100 ROLLER CHAIN x 126P (USE ON STANDARD DRIVE TRUCK, TRAILER & STATIONARY)	1
	321126 SH	SUPER 100H ROLLER CHAIN x 126P (USED ON HEAVY DRIVE TRUCK, TRAILER & STATIONARY)	1
10	321282	RS120 ROLLER CHAIN x 81P (USED ON STANDARD DRIVE TRUCK, TRAILER & STATIONARY)	1
	321282 SH	SUPER 120H ROLLER CHAIN x 82P (USED ON HEAVY DRIVE TRUCK, TRAILER & STATIONARY)	1
			1
11	321482	RS140 ROLLER CHAIN x 112P (USE ON STANDARD DRIVE TRUCK, TRAILER & STATIONARY)	1
	321482 SH	SUPER 140H ROLLER CHAIN x 112P (USED ON HEAVY DRIVE TRUCK, TRAILER & STATIONARY)	1
12	400206	HEX NUT 3/8"-16 #5 PLTD	8
13	400910	HEX CROWN LOCNUT 5/8"-11 #9 PLTD	4
14	402406	FLAT WASHER 3/8" PLTD	4
15	402510	FLAT WASHER 5/8" SAE PLTD	4
16	405754	HHCS, 5/8"-11 x 2" #5 PLTD	17
17	405762	HHCS 5/8"-11 x 4" #5 PLTD	2
18	405763	HHCS 5/8"-11 x 4-1/2" #5 PLTD	1
19	410012	PULL SPRING 1-3/4" x 7"	5
20	410851	EYE BOLT 3/8" X 6"	1
21	410852	EYE BOLT 3/8" X 8"	3
22	411805	S - HOOK 5/16"	8
23	412416	SET COLLAR 1" PLTD	8
24	873181	IDLER ARM 5/8"BORE	1
25	873182	IDLER ARM WA, 5/8" BORE	1
26	873203	IDLER ARM SIDE PULL WA	1
27	873204	IDLER ARM W.A. - 16" C-C	1

620-16XD DRIVE ASSEMBLY USED ON SERIAL #'s 410729151 THRU 411029266

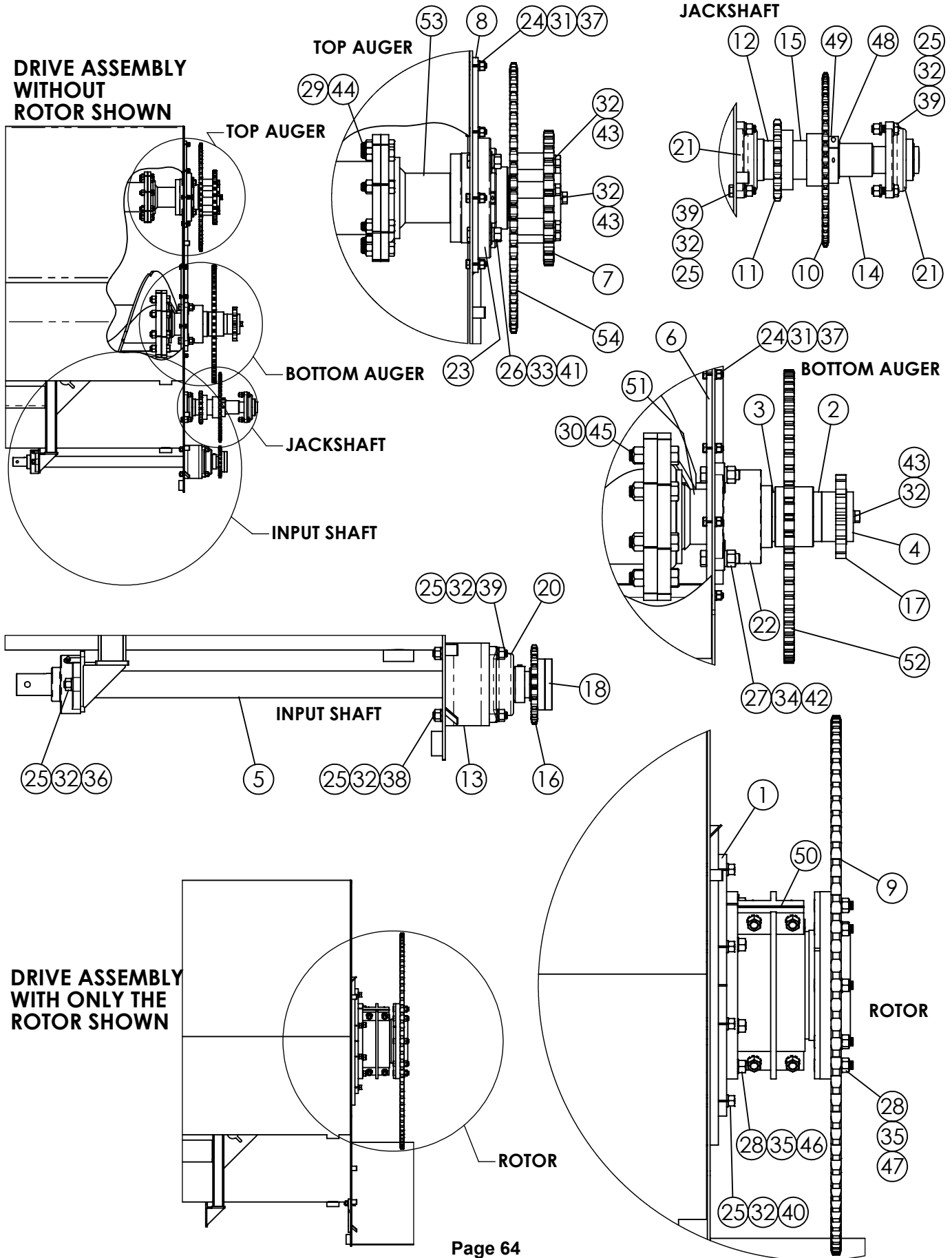

620-16XD DRIVE ASSEMBLY USED ON SERIAL #'s 410729151 THRU 411029266

ITEM #	PART #	DESCRIPTION	QTY
1	185270	ROTOR BEARING PLATE	2
2	185313	SHAFT SPACER, 4" x 3/4"	1
3	185320	SHAFT SPROCKET SPACER - 1/4" x 4"	1
4	185329	SPROCKET WASHER 3 1/2" SHAFT x 4 1/2"	2
5	185710	INPUT SHAFT, 620	1
6	189633	BOTTOM AUGER BEARING PLATE 620	1
7	189665	SPROCKET, 120A24H 5.515" BORE - (USED WITH ANY BR)	1
	189901	SPROCKET, 120A28H 5.515" BORE - (USED WITH ANY SR)	1
8	189681	TOP AUGER BRG PLT 620	1
9	189942	SPROCKET, 140A86 x 12.030" ID DRILLED	1
10	190396	SPROCKET, 80B48, 3" SPLINE	1
11	190397	SPROCKET, 100B17H, 3" SPLINE	1
12	190399	SHAFT SPACER 3" x 7/8"	1
13	190534	INPUT BEARING MOUNT 2-7/16"	1
14	190749	SPLINED JACKSHAFT 620 (NEW)	1
15	190835	SHAFT SPACER 3" x 1-1/4"	1
16	330821	SPROCKET, 80SF21H RC (USED ON TRUCK & STATIONARY, BR)	1
	330833	SPROCKET, 80SK18H RC (USED ON 1000 PTO TRAILER, BR)	1
	330824	SPROCKET, 80SF24H RC (USED ON 540 PTO TRAILER, BR)	1
	330819	SPROCKET, 80SK19H RC (USED ON TRUCK & STATIONARY, SR)	1
	330815	SPROCKET, 80SK15H RC (USED ON 1000 PTO TRAILER, SR)	1
	330834	SPROCKET, 80SF20H RC (USED ON 540 PTO TRAILER, SR)	1
17	331413	SPROCKET, 140B12H 2.25LTB 3.77ID	1
18	336039	BUSHING, SF 2-7/16" QD (USED ON TRUCK & STATIONARY, BR, 540 PTO TRAILER BR & SR)	1
	336040	BUSHING, SK 2-7/16" QD (USED ON TRUCK & STATIONARY SR, 1000 PTO TRAILER BR & SR)	1
19	340232	BEARING, VCJT 2"-2 BOLT FLANGE	1
20	340438	BEARING, 2 7/16" FLANGE MOUNT	1
21	340439	BEARING, 2 7/16" FLANGE, RCJC	2
22	342064	BEARING, 4" 4-BOLT FLANGED ROLLER	1
23	342159	BEARING, 4", 4-BOLT FLANGED ROLLER	1
24	400208	HEX NUT 1/2"-13 #5 PLTD	20
25	400210	HEX NUT 5/8"-11 #5 PLTD	28
26	400212	HEX NUT 3/4"-10 #5 PLTD	7
27	400214	HEX NUT 7/8"-9 #5 PLTD	4
28	400512	HEX NUT 3/4"-16 #8 PLTD	14
29	400912	HEX CROWN LOCK NUT 3/4"-10 #5 PLTD	8
30	400916	HEX CROWN LOCKNUT, 1"-8 #5 PLTD	8
31	402008	SPRING LOCK WASHER 1/2" PLTD	20
32	402010	SPRING LOCK WASHER 5/8" PLTD	36
33	402012	SPRING LOCK WASHER 3/4" PLTD	7
34	402014	SPRING LOCK WASHER 7/8" MED PLTD	4
35	402112	LOCK WASHER, EXTERNAL STAR 3/4"	14
36	402410	FLAT WASHER 5/8" MED PLTD	2
37	405703	HHCS 1/2"-13 x 1-1/2" #5 PLTD	20
38	405752	HHCS, 5/8"-11 x 1-1/2" #5 PLTD	2
39	405754	HHCS, 5/8"-11 x 2" #5 PLTD	14
40	405756	HHCS, 5/8"-11 x 2-1/2" #5 PLTD	12
41	405781	HHCS 3/4"-10 x 2-1/2" #5 PLTD	7
42	405806	HHCS 7/8"-9 x 3" #5 PLTD	4
43	406454	HHCS 5/8"-11 x 2" #8 PLTD	8
44	406481	HEX BOLT, 3/4-10 x 2-1/2 #8 PITD HHCS	8
45	406528	HHCS 1"-8 x 3-3/4" #8 PLTD	8
46	406781	HHCS 3/4"-16 x 2 1/2" #8 PLTD	6
47	406783	HHCS 3/4"-16 x 3" #8 PLTD	8
48	409961	SNAP RING 3"x.093" SH300	1
49	412434	C-CLAMP COLLAR, 3"	1
50	872037	NYLATRON BEARING ASSY 9 3/4"	1
51	872626	BOTTOM AUGER SHAFT FLANGE W.A. 620	1
52	872635	SPROCKET, 120C54 x 4" SPLINED, WA	1
53	872650	HEAVY TOP AUGER SHAFT FLANGE WA 620 4"	1
54	873199	SPROCKET, 100B60 WA, 4" SPLINED HUB	1

**NOTE: SR = STAGGERED ROTOR
BR = BAR ROTOR**

620-16XD DRIVE ASSEMBLY SERIAL #'s 411129270 THRU CURRENT

DRIVE ASSEMBLY
Rotor not shown

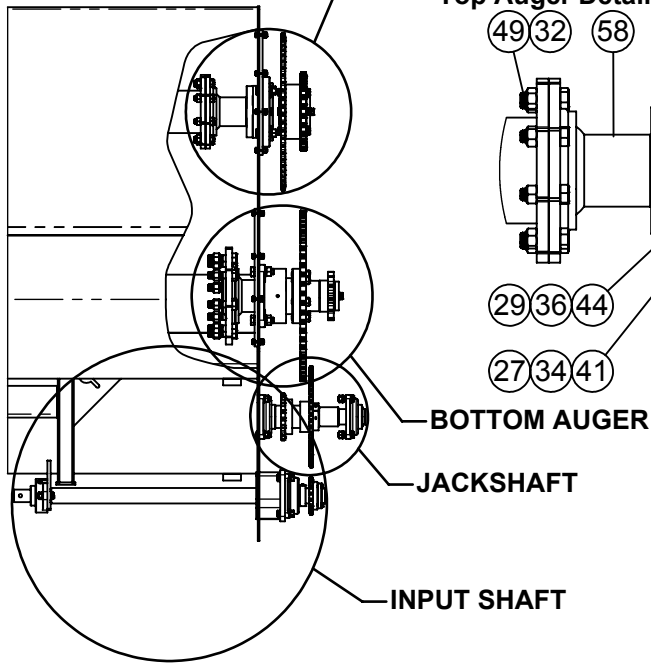

Top Auger Detail

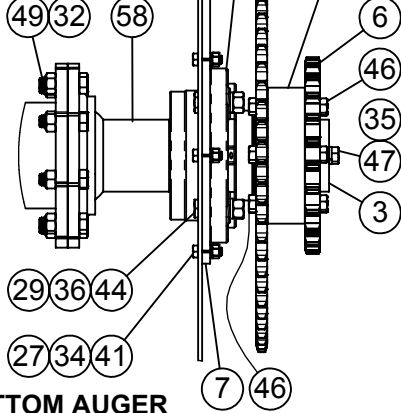

Jackshaft Detail

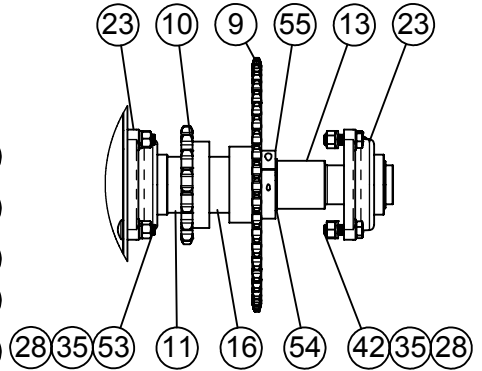

Bottom Auger Detail

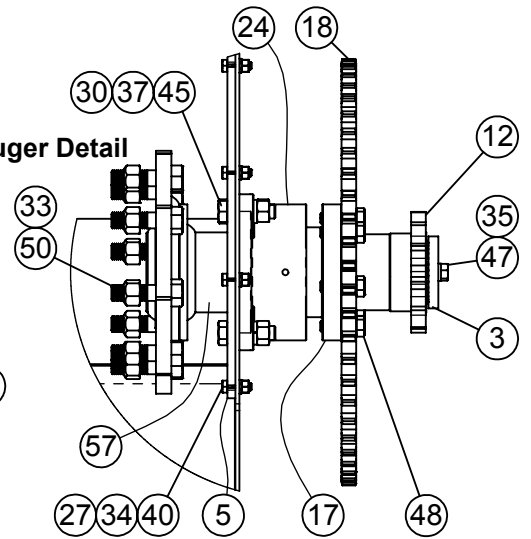

Input Shaft Detail

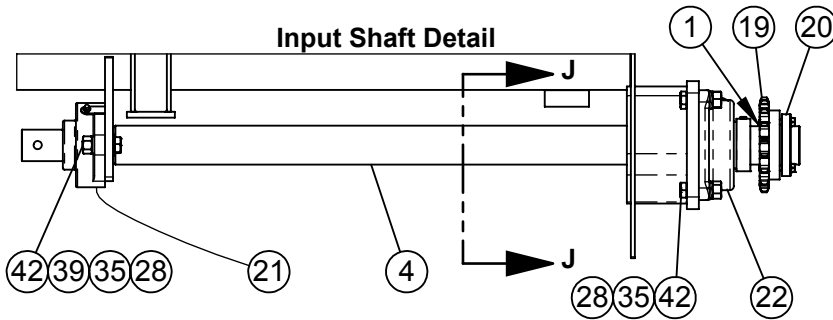

DRIVE ASSEMBLY
Only Rotor shown

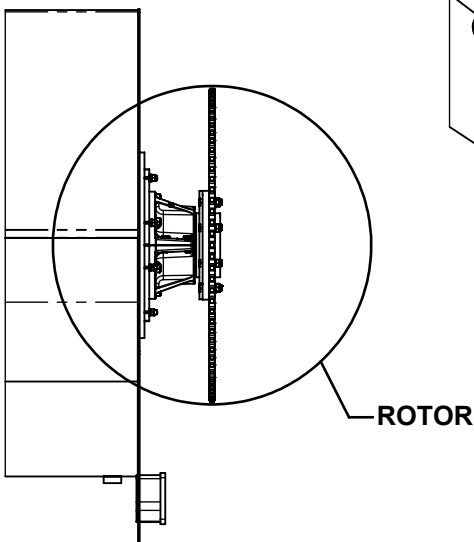

SECTION J-J

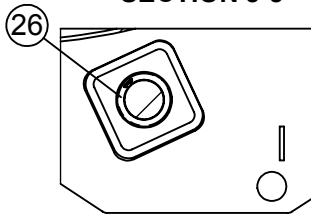

Rotor Detail

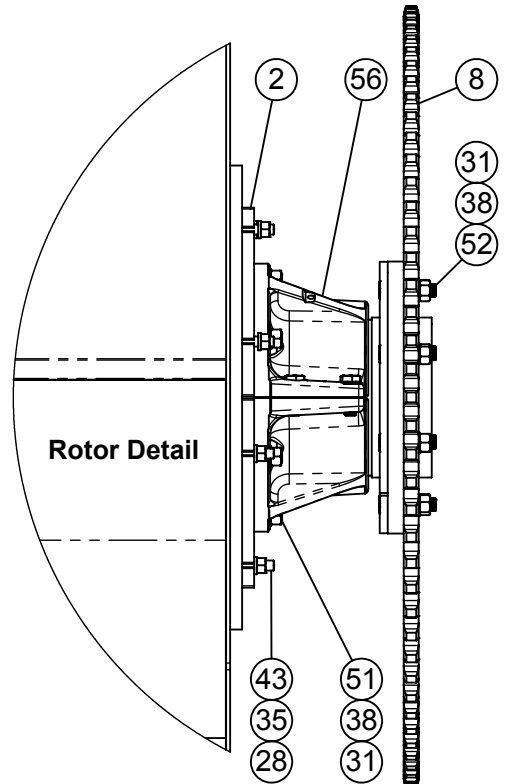

620-16XD DRIVE ASSEMBLY SERIAL #'s 411129270 THRU CURRENT

ITEM #	PART #	DESCRIPTION	QTY.
1	150514	KEY, 1/2" x 5/8" x 2"	1
2	185270	ROTOR BEARING PLATE	2
3	185329	SPROCKET WASHER 3 1/2" SHAFT x 4 1/2"	2
4	185710	INPUT SHAFT, 620	1
5	189633	BOTTOM AUGER BEARING PLATE 620	1
6	189901	SPROCKET, 120A28H 5.515" BORE (Used with all Rotor Types)	1
7	189681	TOP AUGER BRG PLT 620	1
8	189942	SPROCKET, 140A86 x 12.030" ID DRILLED	1
9	190396	SPROCKET, 80B48, 3" SPLINE	1
10	190397	SPROCKET, 100B17H, 3" SPLINE	1
11	190399	SHAFT SPACER 3" x 7/8"	1
12	190727	SPROCKET, 140B12H x 4" SPL BORE	1
13	190749	SPLINED JACKSHAFT 620XD	1
14	190828	SPLINED TOP AUG SPRKT SPACER	1
15	190829	SPROCKET, 100A60 x 5.515 BORE	1
16	190835	SHAFT SPACER 3" x 1-1/4"	1
17	190841	SPLINED BOTTOM AUGER SPROCKET HUB BLANK	1
18	190846	SPROCKET, 120A54 5.515" BORE W/HOLES	1
19	330817	SPROCKET, 80SK17H RC (Used on Truck, Stationary & 1000 PTO Trailers)	1
	330823	SPROCKET, 80SF23RC (Used on 540 PTO Trailers)	1
20	336040	BUSHING, SK 2 7/16" QD (Used on Truck, Stationary & 1000 PTO Trailers)	1
	336039	BUSHING, SF 2-7/16" QD (Used on 540 PTO Trailers)	
21	340232	BEARING, VCJT 2"-2 BOLT FLANGE	1
22	340438	BEARING, 2 7/16" FLANGE MOUNT	1
23	340439	BEARING, 2 7/16" FLANGE, RCJC	3
24	342064	BEARING, FLANGED ROLLER ZB2400	1
25	342159	BEARING, 4", 4-BOLT FLANGED ROLLER	1
26	355039	Seal-CR 24287 2-7/16" ID	1
27	400208	HEX NUT 1/2"-13 #5 PLTD	20
28	400210	HEX NUT 5/8"-11 #5 PLTD	30
29	400212	HEX NUT 3/4"-10 #5 PLTD	8
30	400214	HEX NUT 7/8"-9 #5 PLTD	4
31	400512	HEX NUT 3/4"-16 #8 PLTD	14
32	400912	HEX CROWN LOCK NUT 3/4"-10 #5 PLTD	8
33	400916	HEX CROWN LOCKNUT, 1"-8 #5 PLTD	8
34	402008	SPRING LOCK WASHER 1/2" PLTD	20
35	402010	SPRING LOCK WASHER 5/8" PLTD	33
36	402012	SPRING LOCK WASHER 3/4" PLTD	8
37	402014	SPRING LOCK WASHER 7/8" MED PLTD	4
38	402112	LOCK WASHER, EXTERNAL STAR 3/4"	14
39	402510	FLAT WASHER 5/8" SAE PLTD	2
40	405703	HHCS 1/2"-13 x 1-1/2" #5 PLTD	11
41	405703	HHCS 1/2"-13 x 1-1/2" #5 PLTD	9
42	405754	HHCS, 5/8"-11 x 2" #5 PLTD	14
43	405758	HHCS 5/8"-11 x 3" #5 PLTD	12
44	405781	HHCS 3/4"-10 x 2-1/2" #5 PLTD	4
45	405806	HHCS 7/8"-9 x 3" #5 PLTD	4
46	406453	HHCS 5/8"-11 x 1-3/4" #8 PLTD	12
47	406454	HHCS 5/8"-11 x 2" #8 PLTD	2
48	406480	HHCS 3/4"-10 x 2-1/4" #8 PITD	6
49	406481	HEX BOLT, 3/4-10 x 2-1/2 #8 PITD HHCS	8
50	406528	HHCS 1"-8 x 3-3/4" #8 PLTD	8
51	406781	HHCS 3/4"-16 x 2 1/2" #8 PLTD	6
52	406783	HHCS 3/4"-16 x 3" #8 PLTD	8
53	407121	CHCS 5/8"-11 x 2" #5 PLTD	4
54	409961	SNAP RING 3"x.093" SH300	1
55	412434	C-CLAMP COLLAR, 3"	1
56	782037	NYLATRON CAST BEARING ASSY	1
57	872626	BOTTOM AUGER SHAFT FLANGE W.A. 620	2
58	872650	HEAVY TOP AUGER SHAFT FLANGE WA 620 4"	1

620-16 DRIVE ASSEMBLY

ITEM #	PART #	DESCRIPTION	QTY.
31	330819	Sprocket 80SK19H RC (Std. Truck)	1
	331017	Sprocket 100SF17H (Heavy Truck)	1
	330815	Sprocket 80SK15H (Std 1000rpm Trailer)	1
	331015	Sprocket 100SF15H (Hvy 1000, Std 540 & Hvy 540 Trl)	1
	330817	Sprocket 80SK17H (Staggered Rotor Standard Drive)	1
	331015	Sprocket 100SF15H (Staggered Rotor Heavy Drive)	1
32	340438	Bearing 4-Bolt Flange 2 7/16" RCJ	1
33	190534	Input Bearing Mount 2 7/16"	1
34	355039	Seal CR 24287 2 7/16"	2
35	185710	Shaft 2 7/16" x 48 1/4" Input	1
36	185317	Shaft Spacer 3 1/2" x 1/4"	1
37	189665	Sprocket 120A24H (Std Truck, Std 1000 & 540 Trl)	1
	189683	Sprocket 140A20H (Hvy Truck, Hvy 1000 & 540 Trl)	1
	189901	Sprocket 120A28H 5.5" Drilled (Stag'd Rotor Std Drv)	1
	190358	Sprocket 140A23H 5.5" Drilled (Stag'd Rotor Hvy Drv)	1
38	872636	Sprocket 100B60 (Std Truck, Std 1000 & 540 Trailer)	1
	872649	Sprocket 120B54 (Hvy Truck, Hvy 1000 & 540 Trl)	1
39	321126	Roller Chain #100 x 126P (Std Truck)	1
	321297	Roller Chain #120 x 107P (Hvy Trk Hvy 1000 & 540 Trl)	1
40	321124	Roller Chain #100 x 124P (Std 1000 & 540 Trl)	1
41	187193	Roller Chain #120 x 107P (Hvy Trk Hvy 1000 & 540 Trl)	1
	342156	Shaft Spacer 3 1/2" x 3/32"	1
	342159	Bearing 4-Bolt 3 1/2" REX ZBR2308	1
42	185871	Bearing 4-Bolt 4" ZBR2400 (Hvy Truck, Hvy Trailer)	1
	189681	Top Auger Bearing Plate (Hvy Truck, Hvy Trailer)	1
43	872242	Top Left Rotor Support Tube	1
44	872241	Right Side Rotor Support Tube	2
45	189738	Shaft Sprocket Washer 3 1/2" x 3/8" x 4 1/2"	1
46	185034	Shaft Spacer 3 1/2" x 1/8"	1
47	185287	Shaft Spacer 3 1/2" x .962"	1
48	342056	Bearing 4-Bolt ZB2308 REX 3 1/2"	1
49	185862	Rotor Bearing Plate	1
50	189637	Sprocket 140A86 (Std & Hvy Truck & Trailer)	1
51	321480	Roller Chain #140 x 111P (Std & Hvy Truck & trailer)	1
52	185773	Roller Seal Flange 17" x 1/4"	1
53	185873	Rotor Seal 1/4" x 17" x 9 1/2"	1
54	872330	Rotor Seal Spacer W.A.	1
55	185219	Oil Bath Top Door	2
56	340439	Bearing, RCJC 2-7/16" 4-Bolt	2
57	412434	C-Clamp Collar 3"	1
58	190397	Sprocket, 100B17 3" Spl (Standard & Heavy Truck)	1
	190395	Sprocket, 120B17 3" Spl (Extra Heavy Truck)	1
	189723	Sprocket, 100B13H 3" (Standard 540 & 1000rpm Trailer)	1
	190393	Sprocket, 120B12 3" (Heavy 540 & 1000rpm Trailer)	1
59	190387	Splined Jack Shaft 3" x 12-5/8"	1
60	190399	Shaft Spacer 7/8" x 3"	1
61	190396	Sprocket, 80B48 3" Spl (Std & Hvy Trk, Std 1000rpm Trl)	1
	190394	Sprocket, 100B40 3" Spl (Extra Hvy Trk, Trl & Stationary)	1
	190392	Sprocket, 100B25H 3" Spl (Std & Hvy 540rpm Trl)	1
	190391	Sprocket, 100B48 3" Spl (Heavy 1000rpm Trailer)	1
62	188345	Shaft Spacer 1" x 3"	1

ITEM #	PART #	DESCRIPTION	QTY.
1	189178	Idle Block 2 3/8" x 5/8" #80	1
	187159	Idle Block #100 (Hvy Trk, Hvy 1000 Trl, Std & Hvy 540 Trl)	1
2	412416	Set Collar 1"	8
3	872254	Idle Arm W.A. 13"	1
4	187157	Pull Tab 5/8" x 1 1/2" x 3"	4
6	412020	Chain 2/0 x Length	3
7	410852	Eye Bolt 3/8" x 8" x 3/4" x 4"	3
8	872068	Idle Arm W.A. 18"	1
9	185582	Idle Block 2 7/8" x 5/8" #100	1
10	410012	Spring-Pull 1 3/4" x 7" x 7/32"	5
11	185290	Double Spring Pull Bar	2
12	411805	S-Hood Plated 5/16"	2
13	872252	Idle Arm W.A. 23 3/4"	2
14	185621	Idle Block 2 7/8" x 5/8" #120	2
15	410851	Eye Bolt 3/8" x 6" x 3/4" x 7 1/2" x 4"	1
16	185329	Shaft Retainer 5/8" x 4 1/2"	2
17	185320	Shaft Spacer 1/4" x 4"	1
18	189727	Sprocket 140C12H (Std & Heavy Truck & Trailer)	1
19	872635	Sprocket 120C54 (Std Truck, Std 1000 & 540 Trailer)	1
	872648	Sprocket 140C45 (Heavy Truck, Hvy 1000 & 540 Trl)	1
20	321279	Roller Chain #120 x 79P (Std Trk, Std 1000 & 540 Trl)	1
	321200	Connecting Link #120 (Staggered Rotor Std Drive)	1
	321203	Half Link #120 (Staggered Rotor Standard Drive)	1
	321467	Roller Chain #140 x 67P (Hvy Trk, Hvy 1000 & 540 Trl)	1
	321400	Connecting Link #140 (Staggered Rotor Heavy Drive)	1
	321403	Half Link #140 (Staggered Rotor Heavy Drive)	1
21	342064	Bearing 4-Bolt 4" REX ZB2400	1
22	189633	Bottom Auger Bearing Plate 620	1
23	340439	Bearing 4-Bolt Flange 2 7/16" RCJC	2
24	336039	Bushing W/Key SK 2 7/16" QD	1
25	330848	Sprocket 80SF48RC (Std Truck & Std 1000rpm Trl)	1
	331040	Sprocket 100B40, Keyed (Heavy Truck)	1
	331048	Sprocket 100B48, Keyed (Heavy 1000rpm Trailer)	1
	331025	Sprocket 100B25H, Keyed (Std & Heavy 540rpm Trailer)	1
26	320871	Roller Chain #80 x 71P (Std Truck)	1
	321058	Roller Chain #100 x 58P (Heavy Truck)	1
	320869	Roller Chain #80 x 69P (Std 1000rpm Trailer)	1
	321062	Roller Chain #100 x 62P (Heavy 1000rpm Trailer)	1
	321049	Roller Chain #100 x 49P (Std & Hvy 540rpm Trailer)	1
27	189643	Keyed Jackshaft 2-7/16" x 12-5/8", 620-16	1
28	189177	Key 5/8" x 5/8" x 4"	1
29	331002	Sprocket 100B17H x 2 7/16" Bore (Std Truck)	1
	331214	Sprocket 120B14H (Heavy Truck)	1
	331006	Sprocket 100B13H (Std 1000rpm & 540rpm Trailer)	1
	331212	Sprocket 100B12H (Heavy 1000 & 540rpm Trailer)	1
30	336040	Bushing W/Key SK 2 7/16" QD	1
	336039	Bushing SF 2 7/16" QD (Hvy Trk, Hvy Trl, Std 540rpm Trl)	1

620-16 XD STATIONARY ELECTRIC DRIVE

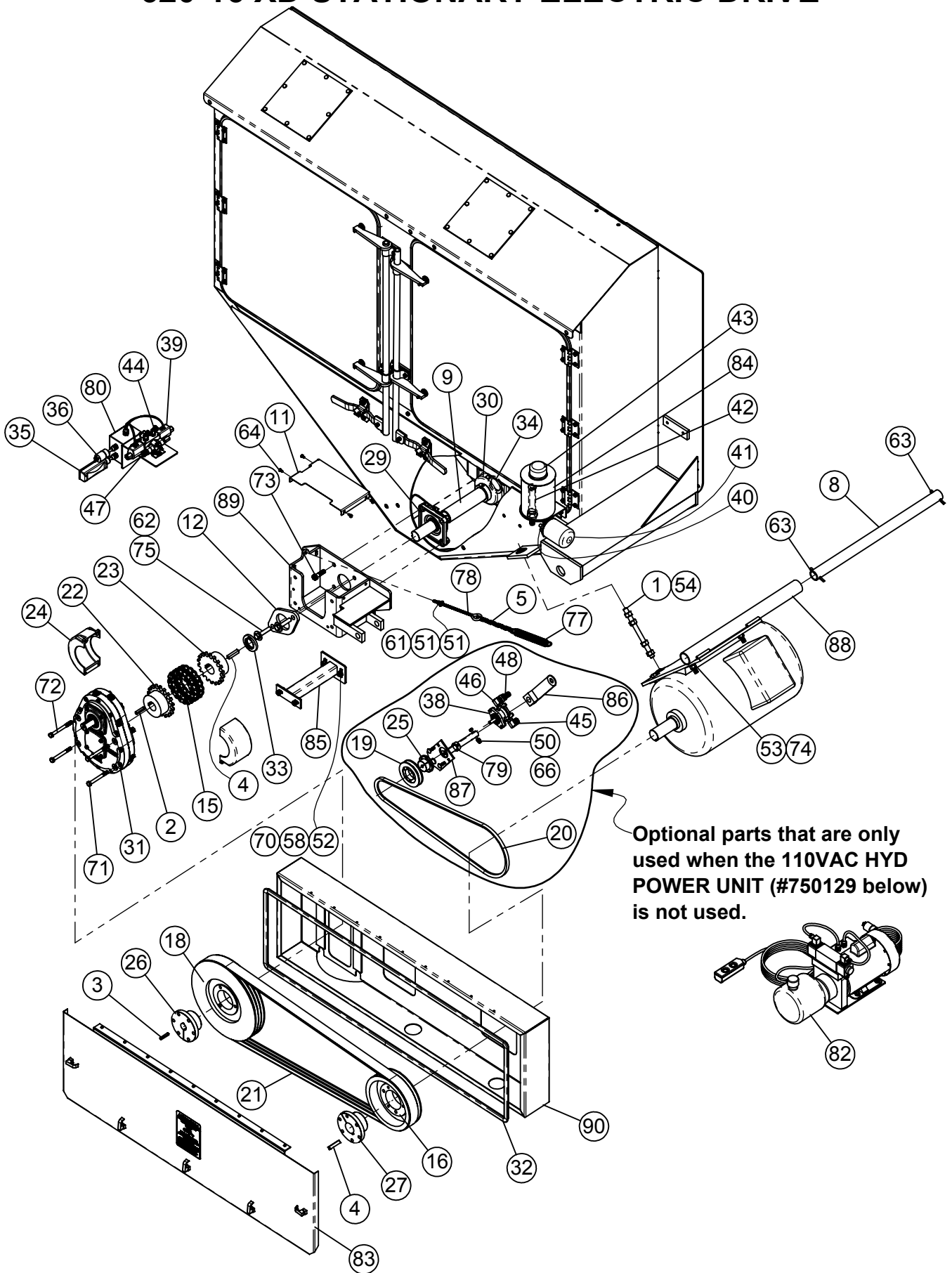

Optional parts that are only used when the 110VAC HYD POWER UNIT (#750129 below) is not used.

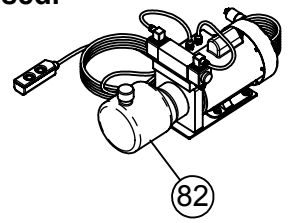

620-16 XD STATIONARY ELECTRIC DRIVE

ITEM #	PART #	DESCRIPTION	QTY.
1	185115	ADJUSTING ALL THREAD, 3/4"-10 x 10"	1
2	185480	KEY 3/8" SQ. X 2"	1
3	185484	KEY 5/16" SQ. X 2"	1
4	185485	KEY, 1/2 x 1/2 x 2-1/2 LG.	2
5	185488	CHAIN-2/0 PASSING LINK	1
8	185948	620 MOTOR PIVOT TUBE 31-1/2"	1
9	185950	620 STA INPUT SHAFT	1
10	189250	ELECTRIC SOLENOID BRACKET - 5 1/2" x 14"	1
11	190854	STATIONARY INPUT COUPLING COVER	1
12	190918	2" SEAL PLATE - 620 STAT	1
15	320818	COUPLER CHAIN #80-2 RC x 18 COMPLETE	1
16	324013	SHEAVE, 5V-4 GROOVE 10.9" E	1
-	324011	SHEAVE, 5V-3 GRV 10.9 SF (Used Only with the 110VAC HYD Power Unit)	1
18	324023	SHEAVE, 5V-3 GRV 16.0 E	1
19	324046	SHEAVE, 1B x 4.6 SDS	1
20	325097	V-BELT Bx-76	1
21	325127	V-BELT, BANDED, 3/5VX-1250	1
22	332617	SPROCKET, COUPLER 80B18 x 1-3/4 CH	1
23	332618	SPROCKET, COUPLER 80B18 x 2 CH	1
24	332619	CHAIN COUPLING COVER 8018	2
25	336009	BUSHING, SDS 1/2" QD	1
26	336134	QD BUSHING, E x 1-3/8"	1
27	336140	QD BUSHING, E x 2-1/8"	1
-	336034	QD BUSHING 2-1/8 SF (Used Only with the 110VAC HYD Power Unit)	1
29	340432	BEARING RCJC 2" - 4 BOLT FLG	1
30	340438	BEARING, 2 7/16" FLANGE MOUNT	1
31	344040	GEARBOX, 2:1 WEASLER	1
32	351056	RUBBER BULB SEAL 5/32"	1
33	355032	Seal-CR 20098 - 2" ID	1
34	355039	Seal-CR 24287 2-7/16" ID	1
35	357700	SWITCH - HW 4052 PENDANT	1
36	358410	MALE PLUG - WH 1447 120V	1
38	362010	PARKER PUMP - D05AA1A CCW	1
39	362205	Hyd Valve 120V Sngl MV5	1
40	362403	FILTER HEAD 3/4", ZAF-07-25-0	1
41	362440	FILTER ELEMENT - AE-10	1
42	362504	SUCTION SCREEN (200 MESH)	1
43	362550	FILLER CAP ASSY. FLOE EZY - AB1000-3	1
44	368024	HYD SWIVEL 9/16"MOR x 3/8"FPS 45°	2
45	368040	SWIVEL 90v 3/8FPP x 3/4MOR	1
46	368050	ADAPTER 7/8 MOR x 3/4 FPS 90	1
47	368115	STRAIGHT ADAPTER 9/16 MOR x 3/8 FPS	2
48	368512	PUSH LOCK HOSE BARB (3/4)x 3/4" MP	2
50	400205	HEX NUT 5/16"-18 #5 PLTD	2
51	400206	HEX NUT 3/8"-16 #5 PLTD	6
52	400208	HEX NUT 1/2"-13 #5 PLTD	8
53	400210	HEX NUT 5/8"-11 #5 PLTD	4
54	400212	HEX NUT 3/4"-10 #5 PLTD	4
58	402008	SPRING LOCK WASHER 1/2" PLTD	8
61	402406	FLAT WASHER 3/8" PLTD	5
62	402410	FLAT WASHER 5/8" MED PLTD	2
63	404010	COTTER PIN 5/16" x 3" PLTD	2
64	405600	HHCS 1/4"-20 x 1/2" #5 PLTD	4
66	405635	HHCS 5/16"-18 X 2-3/4" #5 PLTD	1
70	405702	HHCS 1/2"-13 x 1-1/4" #5 PLTD	6
71	405714	HHCS 1/2" x 4-1/2" #5 PLTD	2
72	405715	HHCS 1/2"-13 x 5" #5 PLTD	2
73	405755	HHCS 5/8"-11 x 2-1/4" #5 PLTD	2
74	405756	HHCS, 5/8"-11 x 2-1/2" #5 PLTD	4
75	405758	HHCS 5/8"-11 x 3" #5 PLTD	2
77	410008	PULL SPRING 1 1/4" X 5 1/4"	1
78	410852	EYE BOLT 3/8" X 8"	1
79	412416	SET COLLAR 1" PLTD	2
80	453717	J-BOX SHELL	1
82	750129	110VAC HYD POWER UNIT	1
83	781442	620/450 ELEC BELT SHIELD DOOR ASSY	1
84	870477	OIL RESERVOIR W.A.	1
85	872003W	BELT SHIELD SUPPORT	1
86	872136	PUMP LEVER ARM	1
87	872138	PUMP SWING ARM	1
88	872671	620/450 ELECTRIC MOTOR BASE W.A. (FITS 50 HP MOTOR - STANDARD)	1
	872724	920 ELECTRIC MOTOR BASE WA (FITS 60 HP MOTOR - OPTIONAL)	1
89	873194	540/620 STA GEARBOX MOUNT W.A. (WEISLER)	1
90	873196	540/620 ELEC BELT SHIELD WA (WEASLER, NYL)	1

ELECTRIC HYDRAULIC POWER UNIT, 110V AC USED ON STATIONARY UNITS

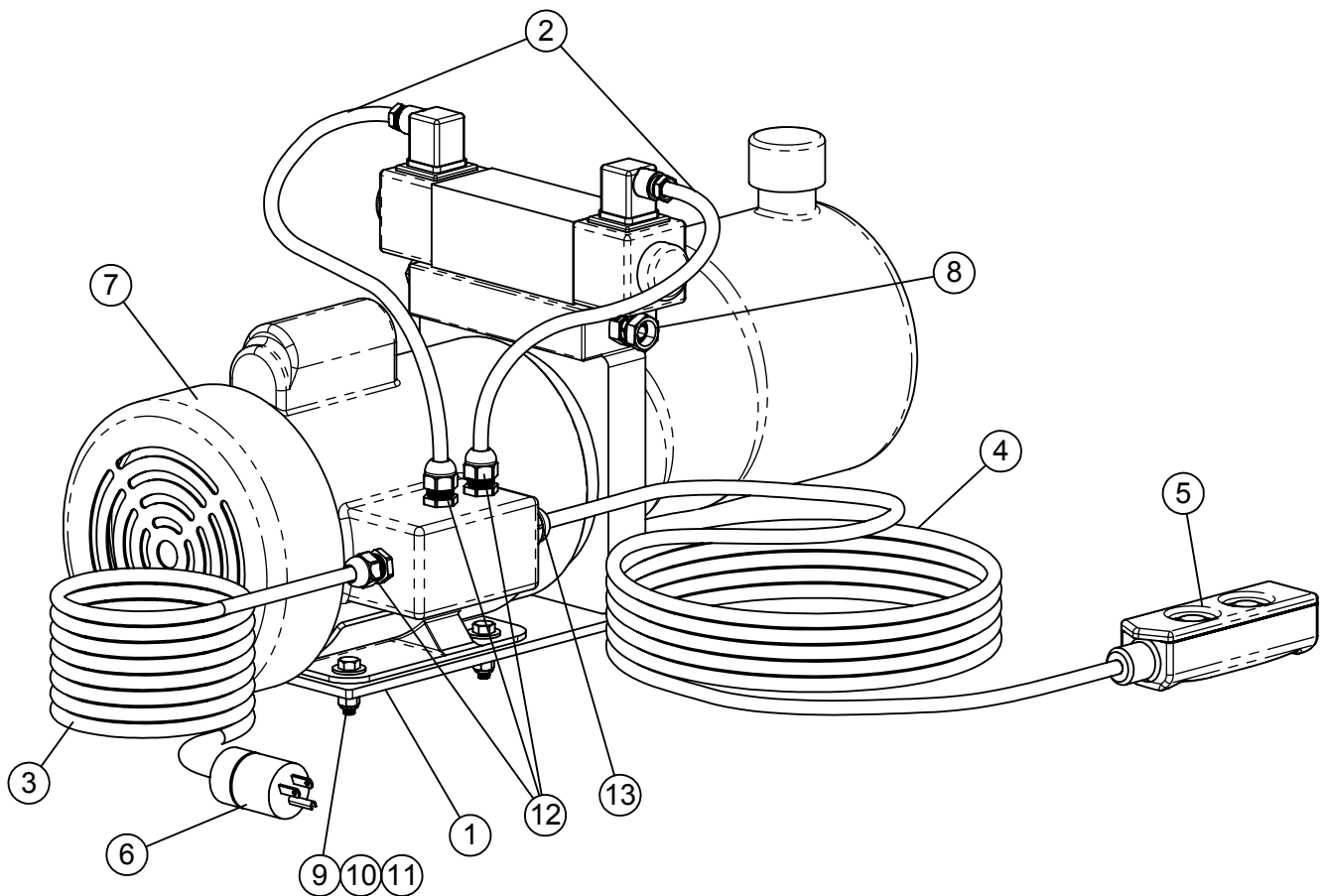

ITEM #	PART #	DESCRIPTION	QTY.
1	150914	POWER UNIT BASE	1
2	185559	ELEC CORD x 26", 14-3 SJO	2
3	185560	ELEC CORD x 14', 14-3 SJO	1
4	185561	ELEC CORD x 25', 14-4 SJO	1
5	357700	SWITCH - HW 4052 PENDANT	1
6	358410	MALE PLUG - WH 1447 120V	1
7	362151	HYDRAULIC POWER UNIT 110V AC	1
8	368115	STRAIGHT ADAPTER 9/16 MOR x 3/8 FPS	2
9	401105	HEX NUT, 5/16"-18 NYLOC #5 PLTD	4
10	402405	FLAT WASHER MED PLTD 5/16"	4
11	405629	HHCS 5/16"-18 x 1-1/4" #5 PLTD	4
12	455310	599-031 COMPRESSION GROMMET	3
13	357010	COMPRESSION GROMMET, 1/2"MP	1

This Page intentionally left blank.

620-16XD 2:1 GEARBOX ASSEMBLY (WEASLER) #344040

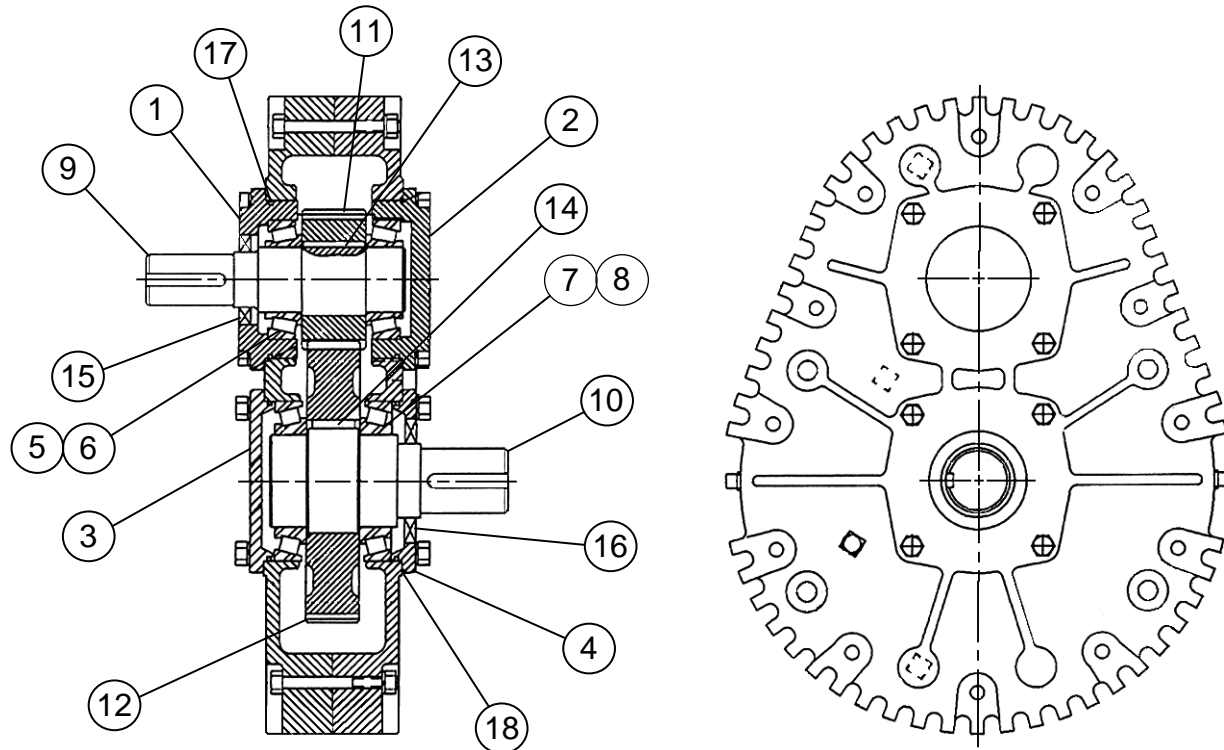

REF #	PART #	DESCRIPTION	QTY.
1	344244	END CAP, OPEN, HIGH SPEED SHAFT	1
2	344245	END CAP, CLOSED, HIGH SPEED SHAFT	1
3	344246	END CAP, CLOSED, LOW SPEED SHAFT	1
4	344247	END CAP, OPEN, LOW SPEED SHAFT	1
5	344248	BEARING CONE 25590, HIGH SPEED SHAFT	2
6	344249	BEARING CUP 25520, HIGH SPEED SHAFT	2
7	344250	BEARING CONE 390A, LOW SPEED SHAFT	2
8	344251	BEARING CUP 394A, LOW SPEED SHAFT	2
9	344252	INPUT SHAFT, HIGH SPEED	1
10	344253	OUTPUT SHAFT, LOW SPEED	1
11	344254	SPUR GEAR, Z=33.DP=9.24	1
12	344255	SPUR GEAR, Z=66.DP=9.24	1
13	344256	KEY, 0.27 x 11.65	1
14	344257	KEY 1/2 x 1.18	1
15	344258	SEAL, 1.50 x 2.44 x 0.315	1
16	344259	SEAL, 3.00 x 3.37 x 0.315	1
17	344260	O-RING, 1.10 x Ø2.65	1
18	344261	GASKET, CAP	4

620-16XD 2:1 GEARBOX (HUB CITY) #344022

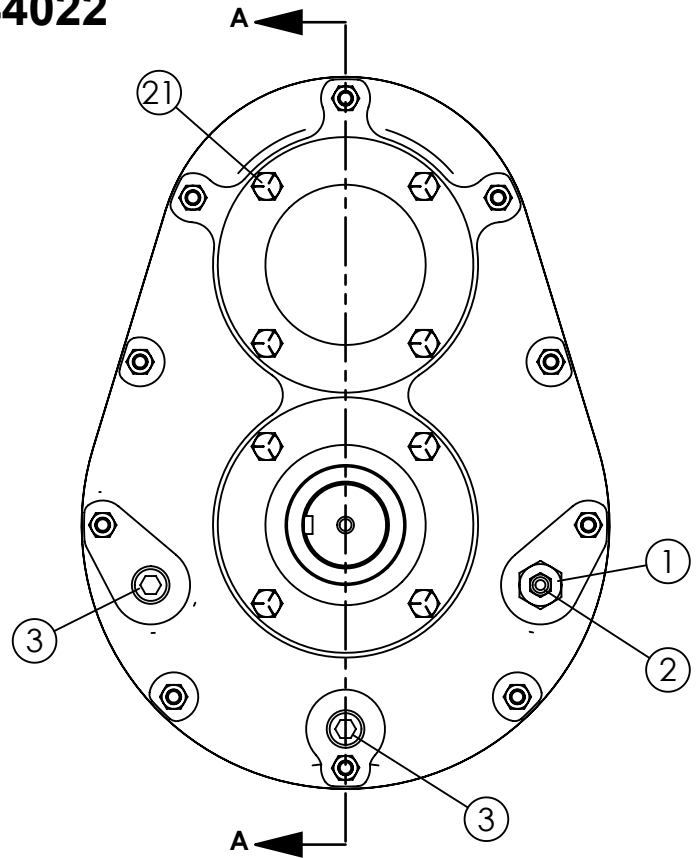
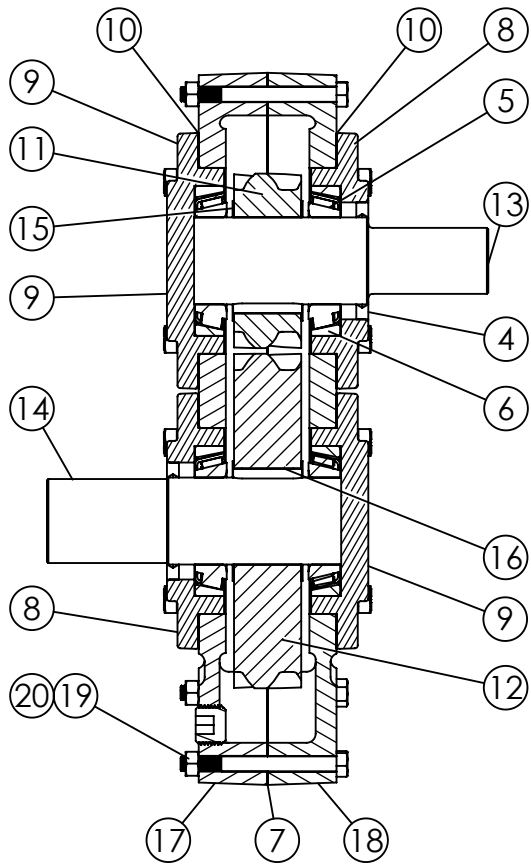

SECTION A-A

ITEM #	PART #	DESCRIPTION	QTY
1	310710	PIPE BUSHING, 1/2" x 1/8" GALV	1
2	310718	BREATHER PLUG, 1/8" PIPE	1
3	310798	PIPE PLUG, 1/2" INTERNAL HEX	2
4	344209	GEARBOX SEAL 1-3/4" CR 18039	2
5	344210	BEARING CONE 1-13/16" ID 18690	4
6	344211	BEARING CUP 3-1/8" OD 18620	4
7	344212	CENTER CASE GASKET DC	1
8	344213	OPEN END CAP HUB CITY	2
9	344214	CLOSED END CAP HUB CITY	2
10	344215	CAP GASKET HC .002	4
11	344216	HIGH SPEED HELICAL GEAR 20T	1
12	344217	LOW SPEED HELICAL GEAR 40T	1
13	344218	HIGH SPEED SHAFT 1-3/8" HC 2:1	1
14	344223	LOW SPEED SHAFT 1-3/4" HC 2:1	1
15	344267	SPACER HUB CITY GEARBOX	4
16	344268	GEARBOX KEY 3/8"sq x 1-7/16" HC	2
17	344269	HOUSING HALF W/PIPE PLUGS HC	1
18	344270	HOUSING HALF WO/PIPE PLUGS HC	1
19	400205	HEX NUT 5/16"-18 #5 PLTD	10
20	405637	HHCS 5/16"-18 x 3-1/4" #5 PLTD	10
21	405653	HHCS 3/8"-16 x 1" #5 PLTD	16

620-16XD TRUCK DRIVELINE ASSEMBLY

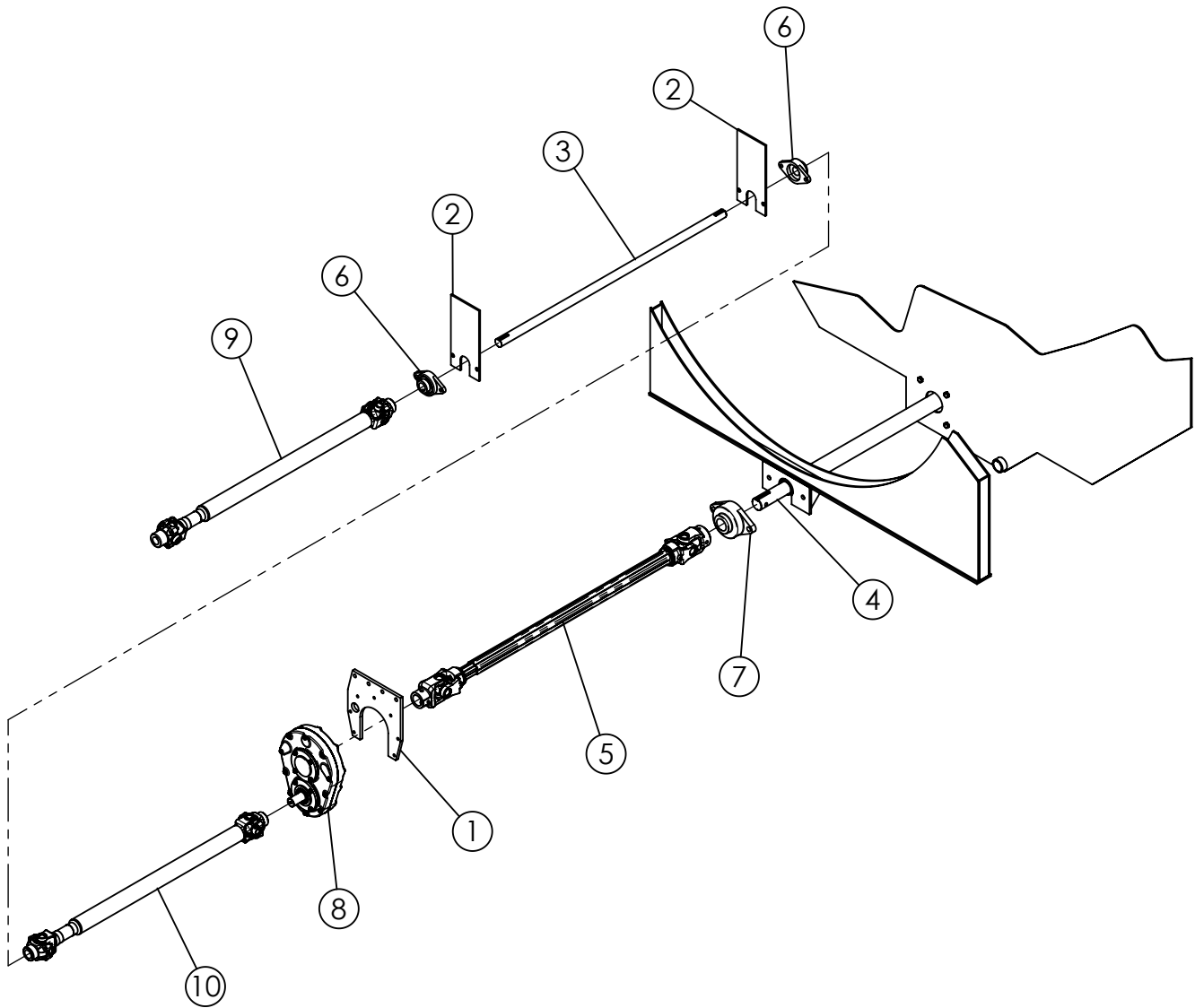

ITEM #	PART #	DESCRIPTION	QTY.
1	191974	GEAR BOX PLATE	1
2	183319	TRUCK JACKSHAFT BRACKET	2
3	185504	JACKSHAFT, 700 TRK, 1-3/8" x 48"	1
4	190487	700 INPUT SHAFT 2-7/16" x 50-3/4"	1
5	338048	TRUCK DRIVE SHAFT	1
6	340222	BEARING, 1 3/8" VCJT	2
7	340232	BEARING, 2", 2 BOLT FLANGE, VCJT	1
8	344022	GEARBOX 2-1 HUB CITY 200	1
9	780488	1350 DRIVESHAFT ASSY 1-1/4" x 1-3/8"	1
10	780496	1350 DRIVE SHAFT ASSY 1-3/8" x 1-3/8"	1

620-16XD/720-16 TRUCK DRIVELINES

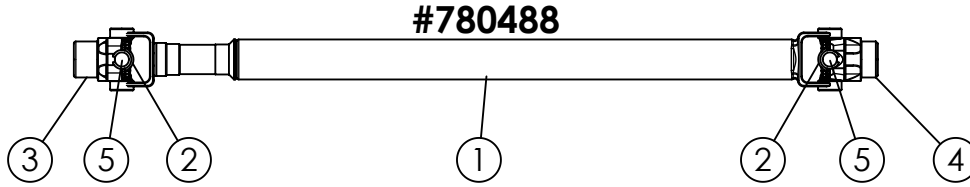

ITEM #	PART #	DESCRIPTION	QTY.
1	338054	DRIVE SHAFT ASSY	1
2	338413	U-STRAP & BOLT KIT 1350	4
3	338423	YOKE 1-1/4" RD BORE, 5/16" KWy	1
4	338424	YOKE 1-3/8" RD BORE, 5/16" KWy	1
5	338436	CROSS KIT, SPICER 1350 5-178X	2

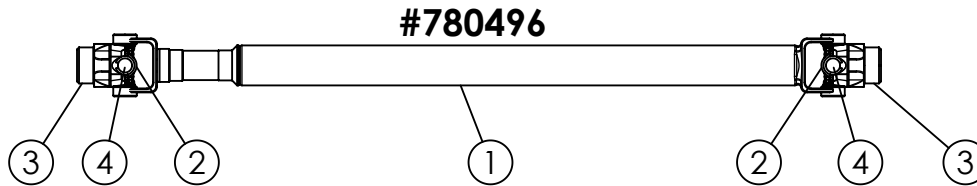

ITEM #	PART #	DESCRIPTION	QTY.
1	338054	DRIVE SHAFT ASSY	1
2	338413	U-STRAP & BOLT KIT 1350	4
3	338424	YOKE 1-3/8" RD BORE, 5/16" KWy	2
4	338436	CROSS KIT, SPICER 1350 5-178X	2

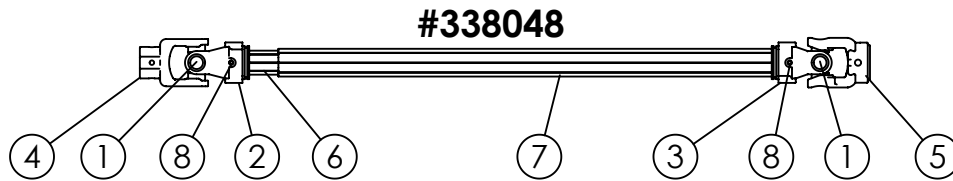

ITEM #	PART #	DESCRIPTION	QTY.
1	338446	CROSS KIT W2500 312209	2
2	338453	INBOARD YOKE W2500 S4 097133	1
3	338454	INBOARD YOKE S5, W2500 097140	1
4	338458	YOKE, 1-3/4" ROUND BORE , 3/8" KEYWAY W2500	1
5	338459	YOKE, 2" ROUND BORE, 1/2" KEYWAY, W2500	1
6	338465	INNER PROFILE S4, W-2400	1
7	338466	OUTER PROFILE, S5L	1
8	338473	ROLL DRIVE PIN W LTSH 10MM x 90MM	2

620-16XD TRAILER DRIVELINE ASSEMBLY (540 RPM)

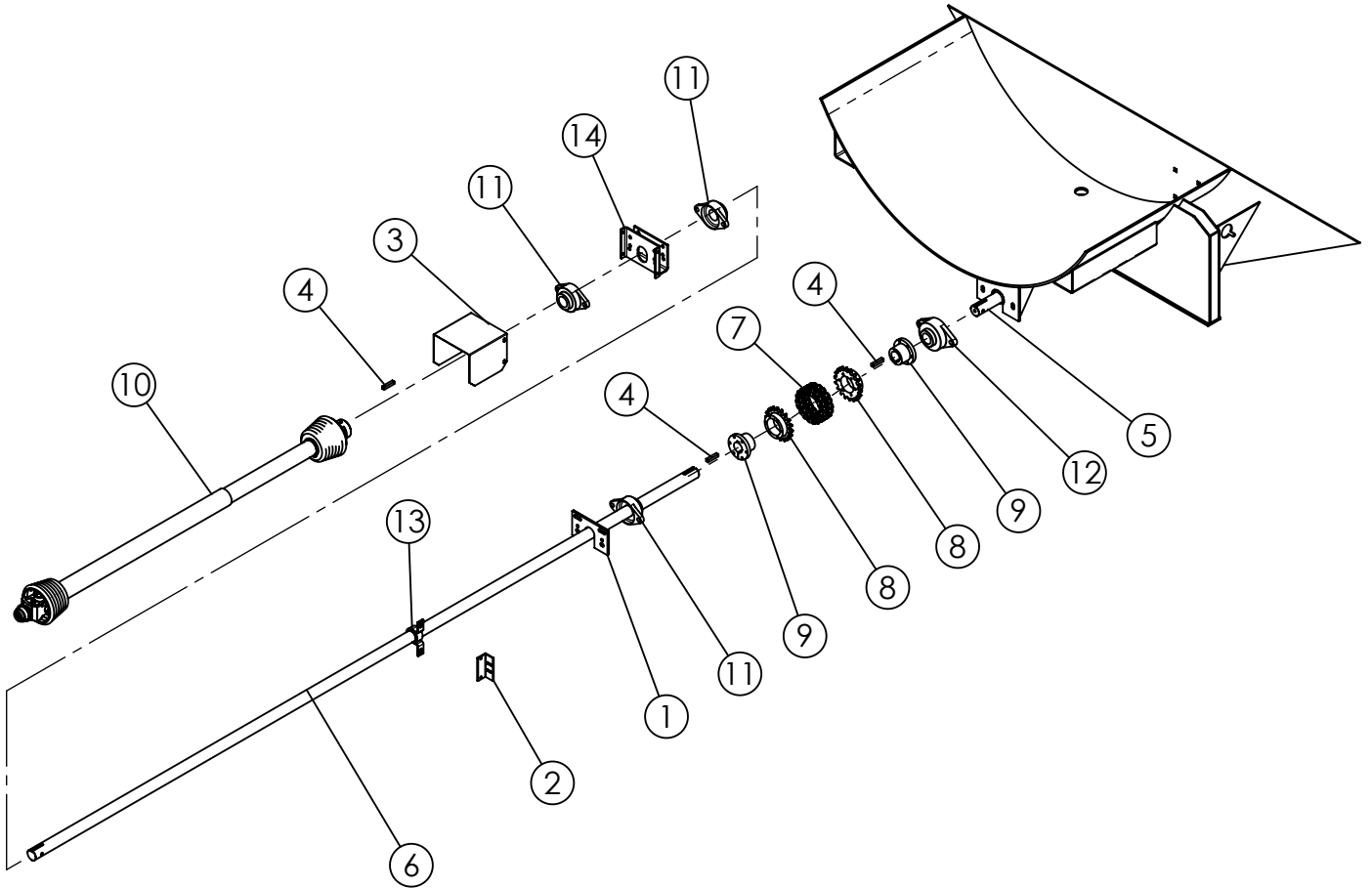

ITEM #	PART #	DESCRIPTION	QTY
1	183277	BEARING HANGER	1
2	185299	CARRIER BEARING ANGLE	1
3	185302	PTO SHIELD	1
4	185485	KEY, 1/2" SQUARE	3
5	185710	INPUT SHAFT, 620	1
6	185771	600 TRAILER DRIVELINE - 540 RPM, 160"	1
7	320818	COUPLER CHAIN #80-2 RC x 18 COMPLETE	1
8	332620	SPROCKET, 80-18 SF CHAIN COUPLING	2
9	336032	BUSHING, 2" QD SF	2
10	338050	DRIVELINE W2500 540, 387566	1
11	340231	BRG. VCJT 2"-2 Bolt Flange-S	3
12	340232	BEARING, 2" - 2 BOLT FLANGE VCJT	1
13	341032	2" PABCO BKP28T-TP W BEARING	1
14	872092	FRONT JACKSHAFT BEARING PLATE	1

TRACTOR TO TRAILER DRIVESHAFT (540 RPM) - #338050

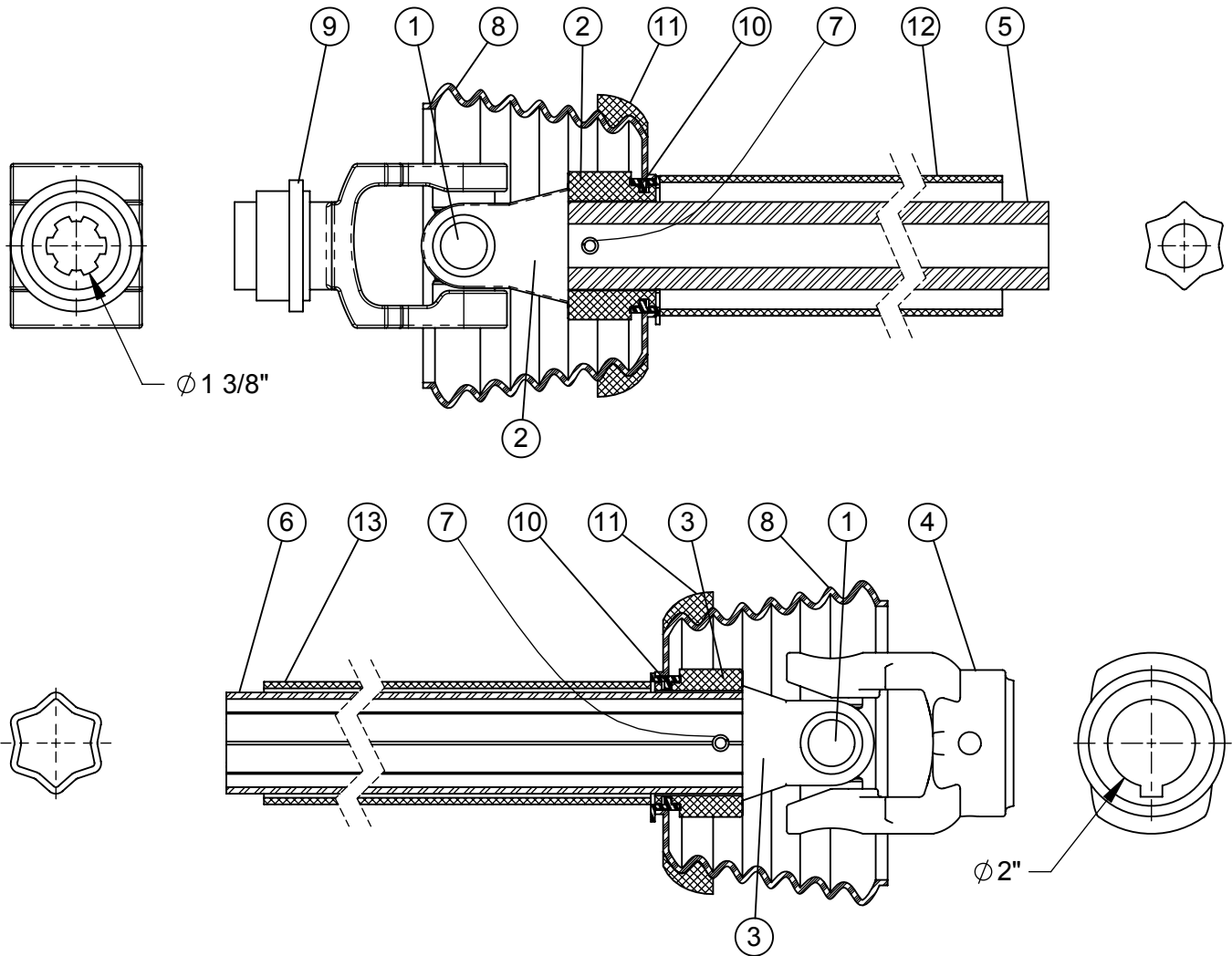

ITEM #	PART #	DESCRIPTION	QTY.
1	338446	CROSS KIT W2500 312209	2
2	338453	INBOARD YOKE W2500 S4 097133	1
3	338454	INBOARD YOKE S5, W2500 097140	1
4	338459	YOKE, 2" RND BORE, 1/2" KEYWAY, W2500	1
5	338465	INNER PROFILE S4, W-2400	1
6	338466	OUTER PROFILE, S5L	1
7	338473	ROLL DRIVE PIN W LTSH 10MM x 90MM	2
8	338473	GUARD CONE 7 RIB	2
9	338482	Yoke, W2500 540 RPM, Quick Disconnect	1
10	338489	BEARING RING SC25, 087276	2
11	338623	REINFORCING COLLAR 359474	2
12	338625	GUARD TUBE, OUTER	1
13	338626	GUARD TUBE, INNER	1

620-16XD TRAILER DRIVELINE ASSEMBLY (1000 RPM)

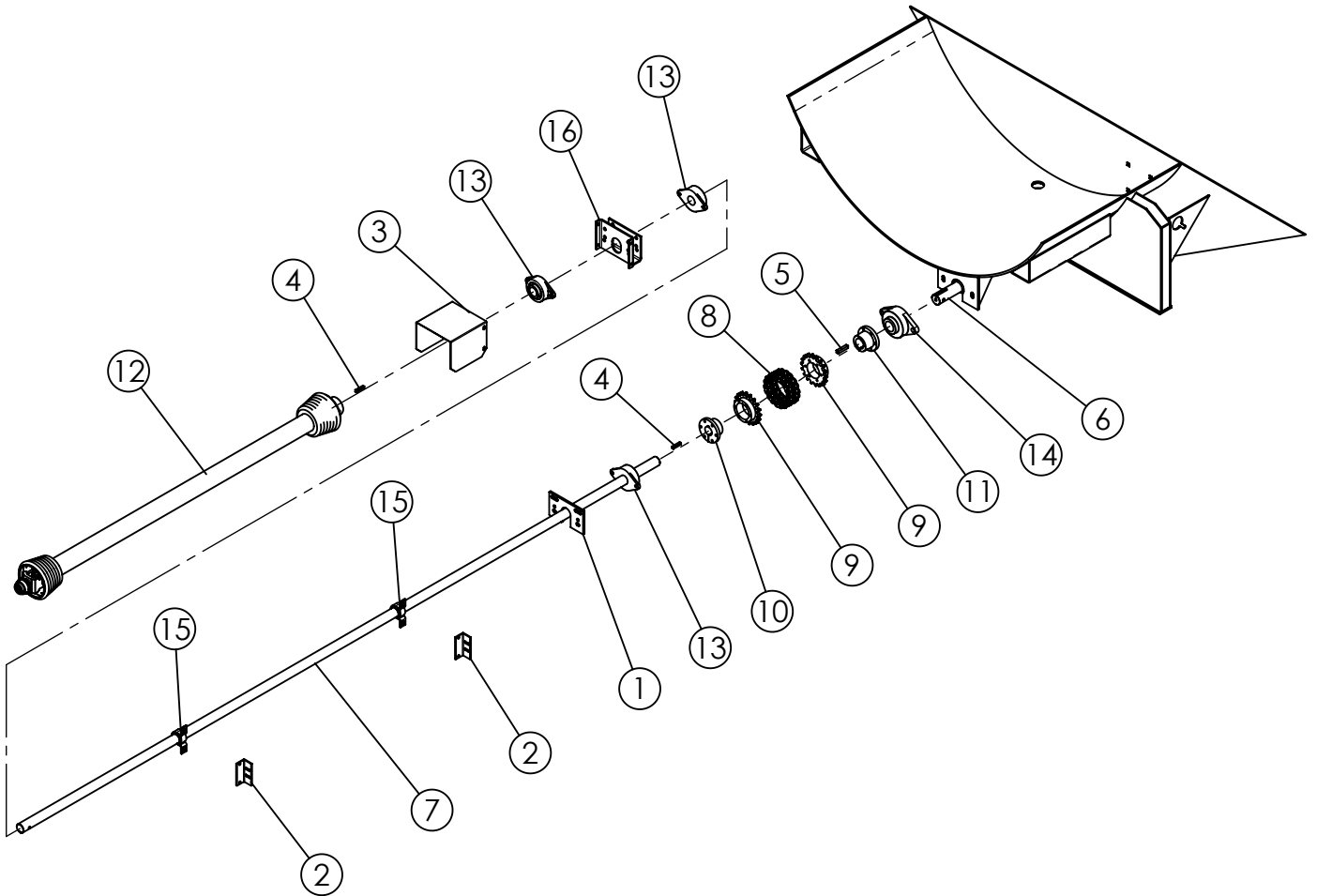

ITEM #	PART #	DESCRIPTION	QTY
1	183277	BEARING HANGER	1
2	185299	CARRIER BEARING ANGLE	2
3	185302	PTO SHIELD	1
4	185480	3/8" SQ. X 2" KEY	2
5	185485	KEY, 1/2" SQUARE	1
6	185710	INPUT SHAFT, 620	1
7	185733	600 TRAILER DRIVELINE 1-3/4"	1
8	320818	COUPLER CHAIN #80-2 RC x 18 COMPLETE	1
9	332620	SPROCKET, 80-18 SF CHAIN COUPLING	2
10	336027	BUSHING, 1-3/4" SF QD	1
11	336032	BUSHING, 2" QD SF	1
12	338058	DRIVE SHAFT W2400 1000 x 1-3/4" Rd	1
13	340228	BEARING, 1-3/4" FLANGE, 2-BOLT	3
14	340232	BEARING, 2" - 2 BOLT FLANGE VCJT	1
15	341028	BEARING, 1-3/4" PABCO BKP28T-TP W	2
16	872092	FRONT JACKSHAFT BEARING PLATE	1

TRACTOR TO TRAILER DRIVESHAFT (1000 RPM) - #338058

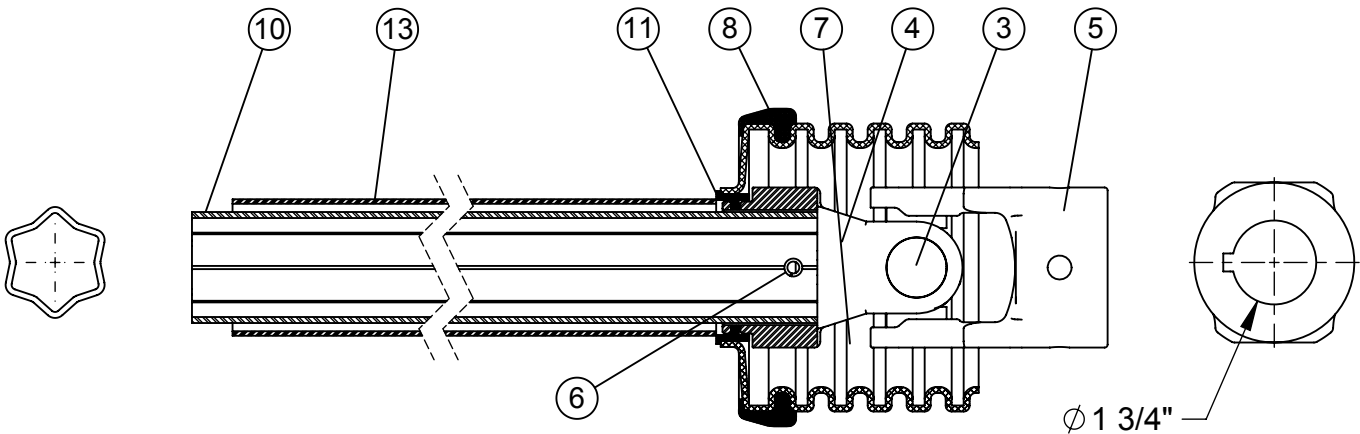
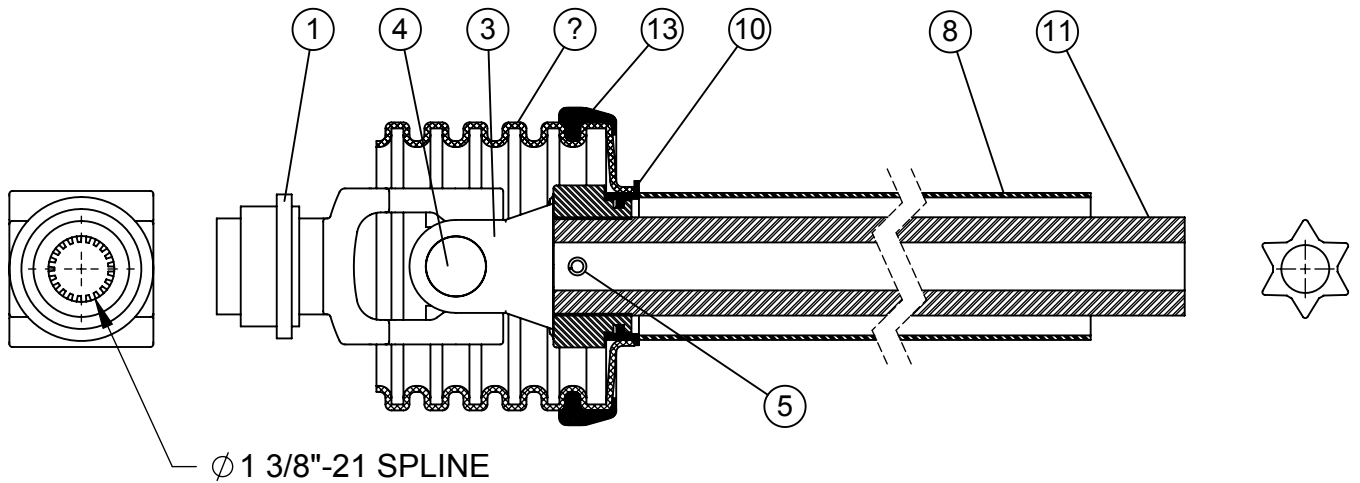

ITEM #	PART #	DESCRIPTION	QTY.
1	338442	SLIDE YOKE 1000 RPM, W2400	1
2	338443	CROSS KIT, W2400	1
3	338450	INBOARD YOKE W2400 S4 356905	1
4	338473	ROLL DRIVE PIN #10MM x 80MM	2
5	338473	ROLL DRIVE PIN W LTSH 10MM x 90MM	2
6	338475	YOKE 1-3/4"RB x 1/2"SC x 3/8"K, W2400	1
7	338486	SHIELD CONE 6-RIB, 365366 W-2400	2
8	338487	OUTER SHIELD TUBE W-2400	1
9	338488	INNER SHIELD TUBE - W-2400	1
10	338489	BEARING RING SC25, 087276	2
11	338568	INNER PROFILE W2400 S4 391623	1
12	338569	OUTER PROFILE S5 W2400 109485	1
13	338623	REINFORCING COLLAR 359474	2

620-16XD FRONT END BEARING ASSEMBLY

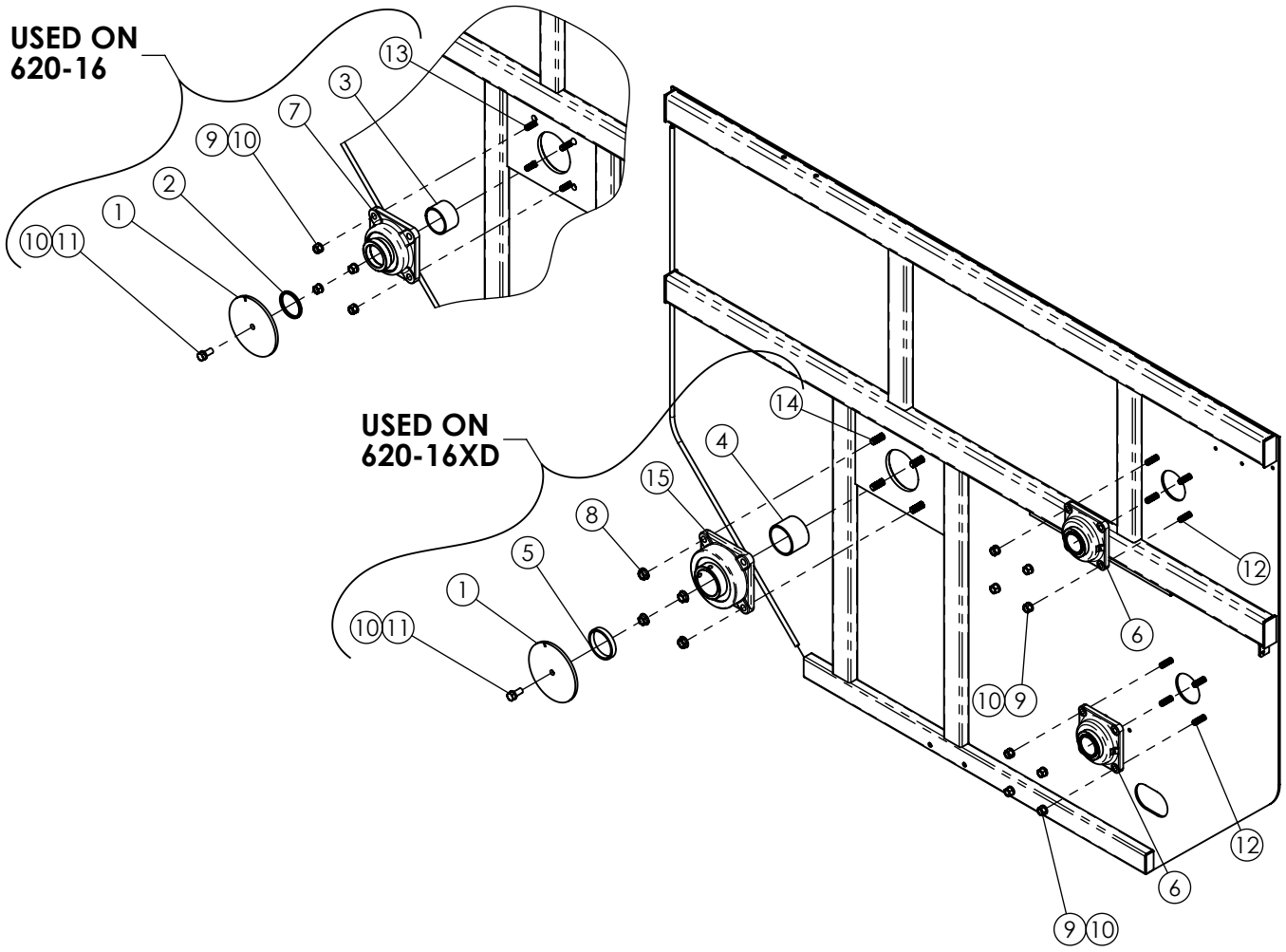

ITEM #	PART #	DESCRIPTION	QTY.
1	185258	ROTOR PLATE INDICATOR, 15/16" OD	1
2	185316	SHAFT SPACER, 1/4" x 3-1/16" ID	1
3	185889	SHAFT SPACER, 2-1/8" x 3-1/16" ID	1
4	192424	SHAFT SPACER, 1-11/16" x 3-1/2" ID	1
5	191969	SHAFT SPACER, 5/8" x 3-1/2" ID	1
6	340439	BEARING, 2 7/16" SQ. FLANGE MOUNT	2
7	340447	BEARING, 4-BOLT-FLANGE, 2-15/16"	1
8	400116	HEX NUT, 3/4"-10 SERRATED FLANGE #5 PLTD	4
9	400210	HEX NUT 5/8"-11 #5 PLTD	8
10	402010	SPRING LOCK WASHER 5/8" PLTD	9
11	405752	HHCS, 5/8"-11 x 1-1/2" #5 PLTD	1
12	405754	HHCS, 5/8"-11 x 2" #5 PLTD	8
13	405756	HHCS, 5/8"-11 x 2-1/2" #5 PLTD	4
14	407932	HHCS, 3/4"-10 x 2-1/2" SERRATED #5 PLTD	4
15	W823890	BEARING, 4-BOLT FLANGE, 3-7/16"	1

620-16XD TRUCK LOAD CELL ASSEMBLY

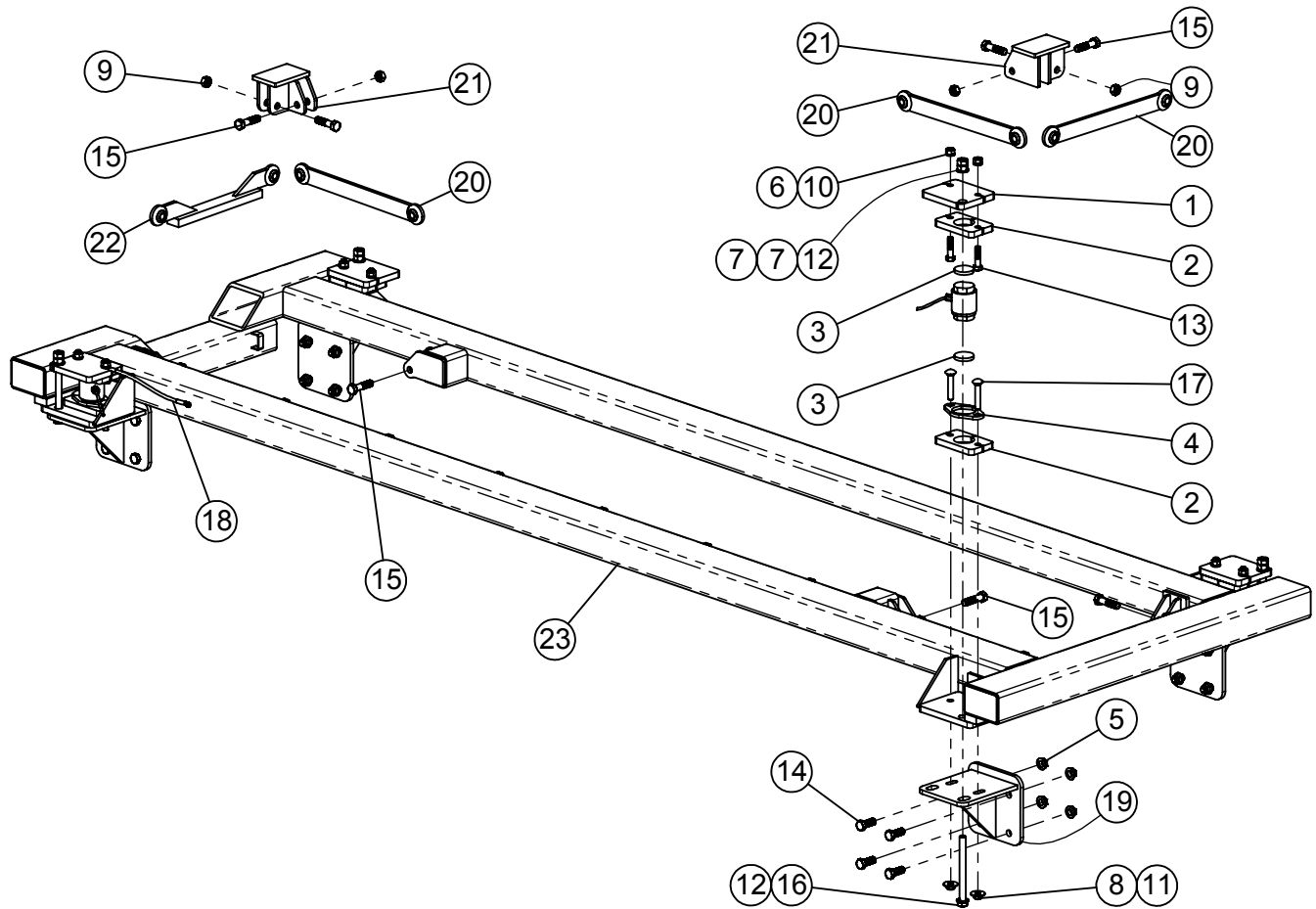

ITEM #	PART #	DESCRIPTION	QTY.
1	182881	SCALE MOUNT MIXER PLATE	4
2	182915	LOAD CELL CAGE PLATE	8
3	185997	SCALE PAD	8
4	192175	LOAD CELL SPPRT PLT, CRG HEAD	4
5	400116	HEX NUT, 3/4"-10 SERRATED FLANGE #5 PLTD	16
6	400210	HEX NUT 5/8"-11 #5 PLTD	8
7	400212	HEX NUT 3/4"-10 #5 PLTD	8
8	400910	HEX CROWN LOCNUT 5/8"-11 #9 PLTD	8
9	400912	HEX CROWN LOCK NUT 3/4"-10 #5 PLTD	8
10	402010	SPRING LOCK WASHER 5/8" PLTD	8
11	402410	FLAT WASHER 5/8" MED PLTD	8
12	402512	FLAT WASHER 3/4" SAE	8
13	405756	HHCS, 5/8"-11 x 2-1/2" #5 PLTD	8
14	405779	HHCS 3/4"-10 x 2" #5 PLTD	16
15	405783	HHCS 3/4"-10 x 3" #5 PLTD	8
16	405798	HHCS #5 PLTD 3/4"-10 x 8-1/2	4
17	407151	CARG BOLT #8 5/8"-11 X 3-1/2	8
18	440412	GROUND STRAP 12"	1
19	830738	BRACKET, SCALE FRAME MOUNT	4
20	870501	SCALE CHECK ROD W.A.	3
21	870519	MIXER SCALE CHECK W.A.	2
22	872053	OFFSET CHECK ROD W.A.	1
23	872188	16' TANDEM SCALE FRAME W.A.	1
	872225	620 SINGLE AXLE SCALE FRAME WA	1

620-16XD TRUCK WEIGH BAR SCALE FRAME ASSEMBLY

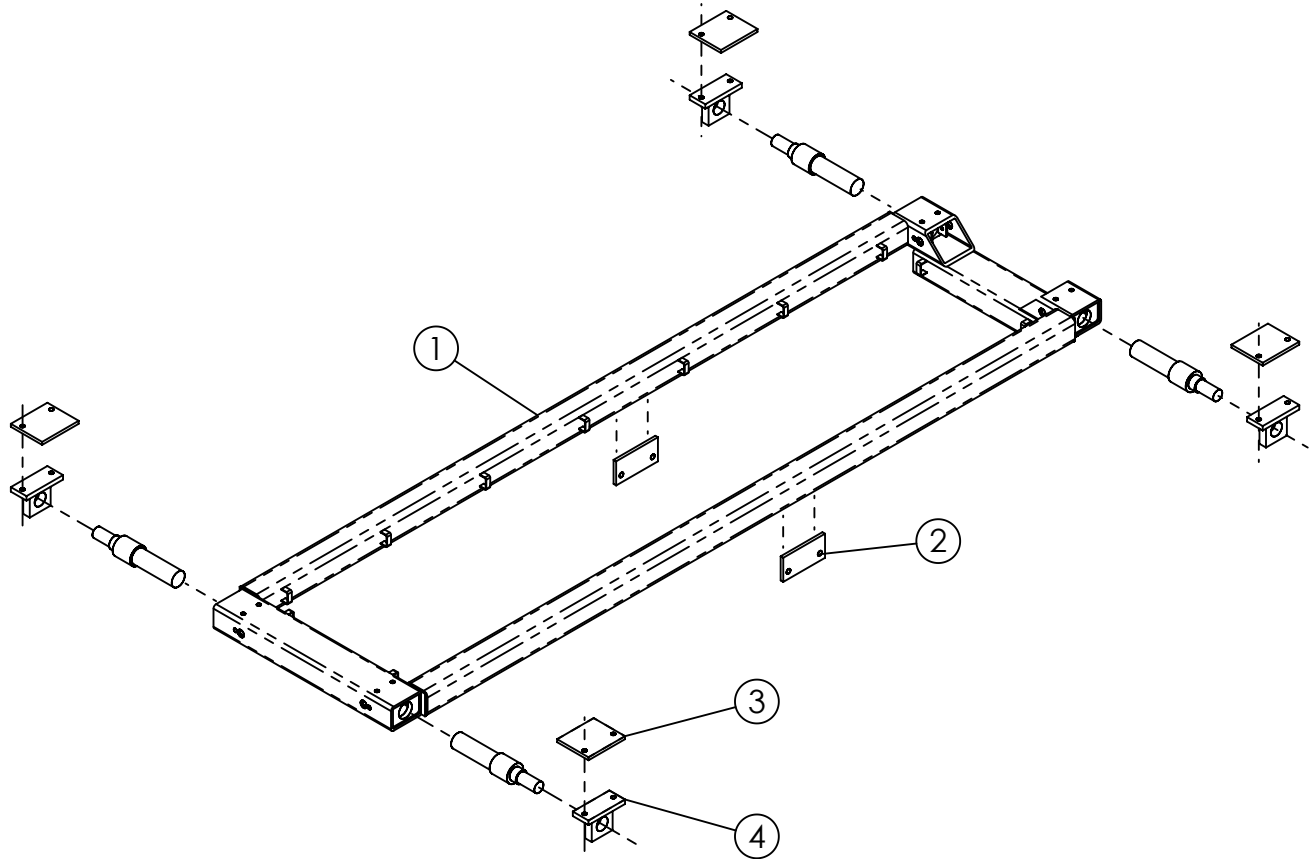

REF #	PART #	DESCRIPTION	QTY.
1	872409	620-16XD TRUCK WEIGH BAR FRAME SCALE W.A.	1
2	182998	TRUCK FRAME BRACKET	6
3	185609	MIXER BAR MOUNT PAD	4
4	872159	WEIGH BAR MOUNT 2 1/2"	4

620-16XD SCALE INDICATOR ARM ASSEMBLY

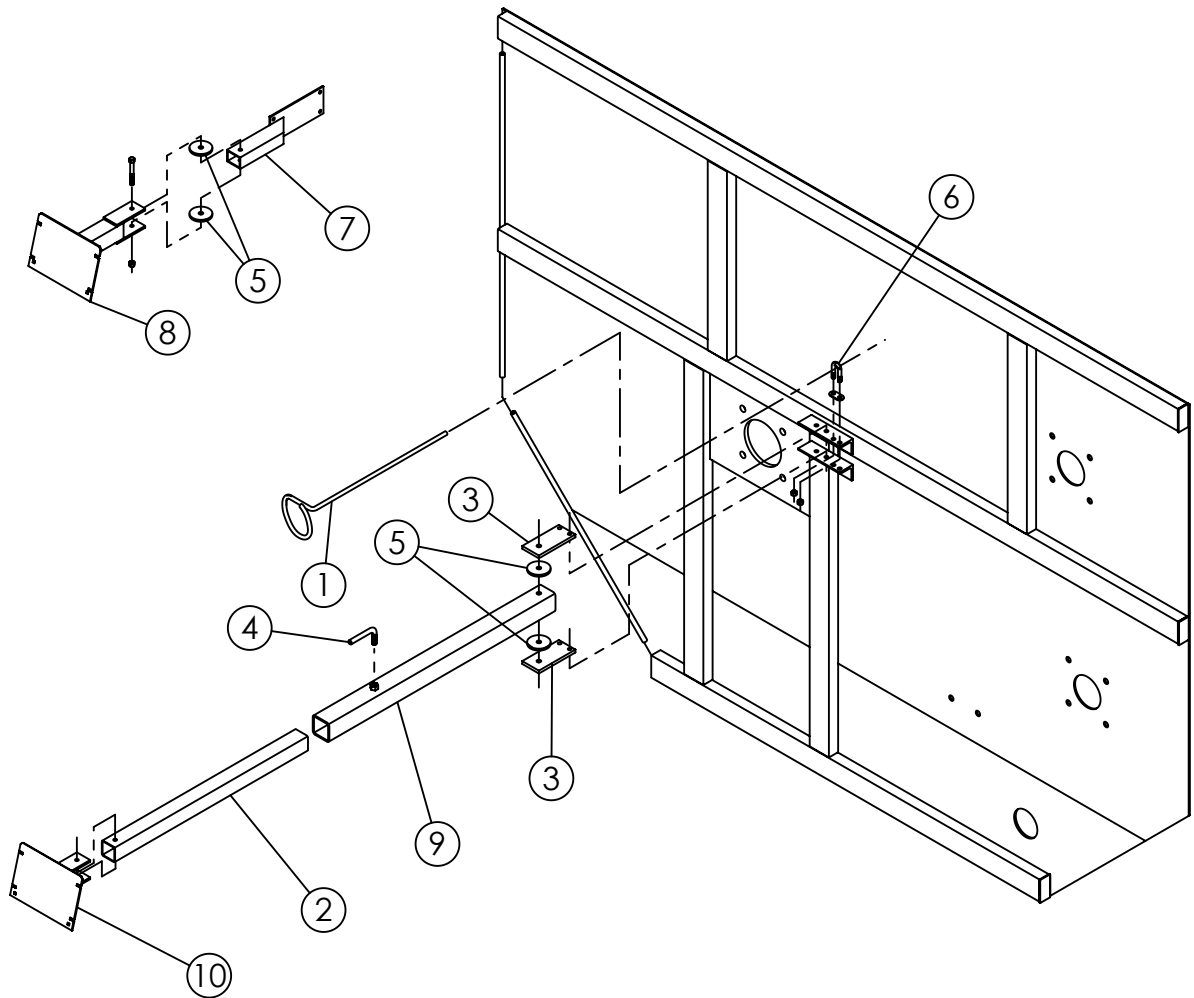

REF #	PART #	DESCRIPTION	QTY.
1	184283	HOSE CARRIER	1
2	185490	TRAILER SCALE INDICATOR TUBE	1
3	185491	SCALE ARM HINGE PLATE	2
4	185492	LOCKING HANDLE 1/2"	1
5	185493	SCALE HINGE WASHER	2
6	412205	CABLE CLAMP 3/8"	1
7	850047	SCALE INDICATOR PLATE WELDMENT	1
8	850048	SCALE INDICATOR ARM WELDMENT	1
9	872125	TRAILER SCALE ARM WELDMENT	1
10	872126	TRAILER SCALE INDICATOR ARM WELDMENT	1

620-16XD TRAILER LOAD CELL SCALE KIT

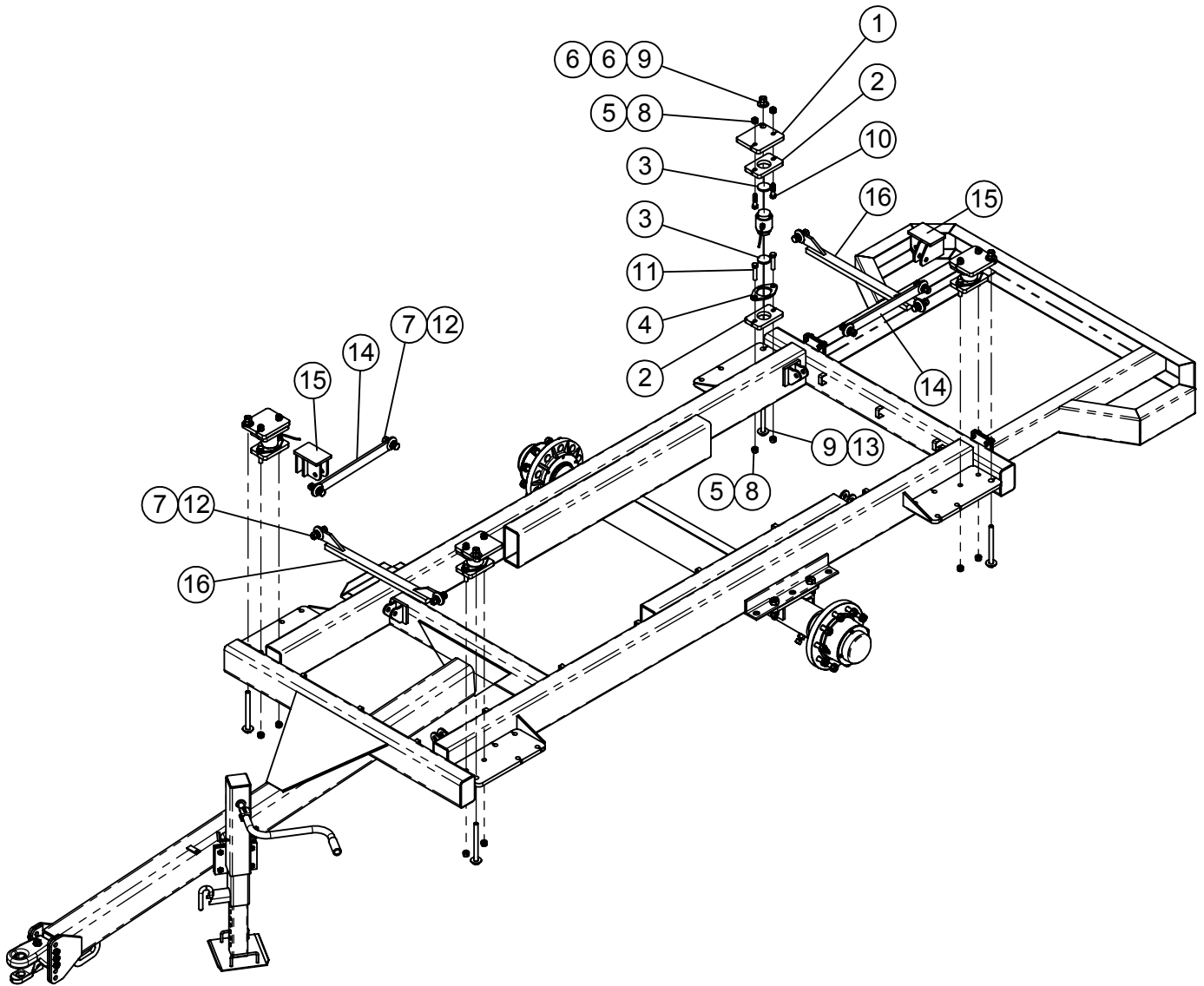

ITEM #	PART #	DESCRIPTION	QTY.
1	182881	SCALE MOUNT MIXER PLATE	4
2	182915	LOAD CELL CAGE PLATE	8
3	185997	SCALE PAD	8
4	190075	DIGI-STAR LOAD CELL SUPPORT PT	4
5	400210	HEX NUT 5/8"-11 #5 PLTD	16
6	400212	HEX NUT 3/4"-10 #5 PLTD	8
7	400912	HEX CROWN LOCK NUT 3/4"-10 #5 PLTD	8
8	402010	SPRING LOCK WASHER 5/8" PLTD	16
9	402412	FLAT WASHER 3/4" PLTD	8
10	405756	HHCS, 5/8"-11 x 2-1/2" #5 PLTD	8
11	405758	HHCS 5/8"-11 x 3" #5 PLTD	8
12	405783	HHCS 3/4-10 x 3" #5 PLTD	8
13	405798	HHCS #5 PLTD 3/4-10 x 8-1/2	4
14	870501	SCALE CHECK ROD W.A.	2
15	870519	MIXER SCALE CHECK W.A.	2
16	872245	TRAILER OFFSET CHECK ROD W.A. 31 1/2"	2

620-16XD TRAILER WEIGH BAR SCALE FRAME ASSEMBLY

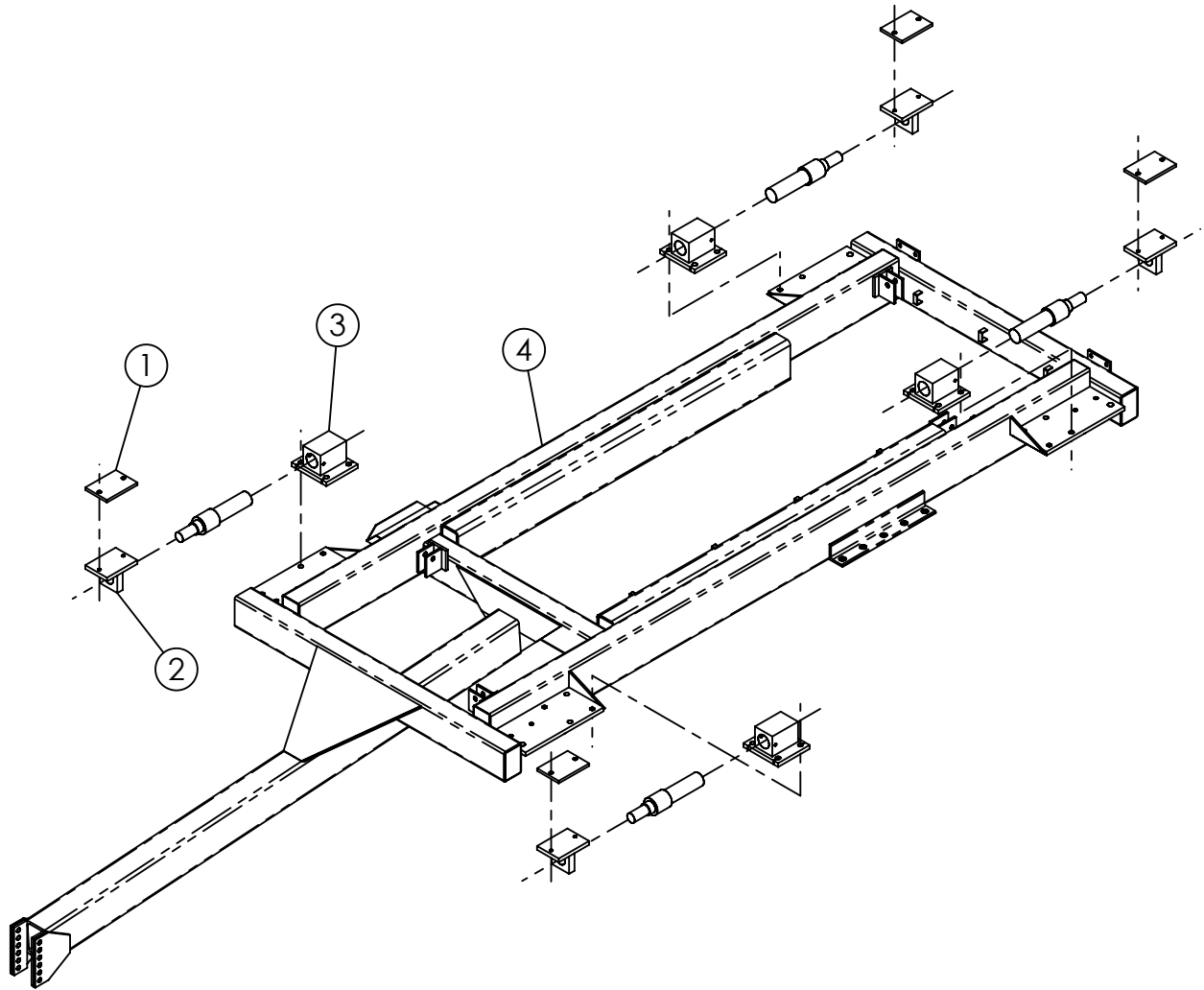

REF #	PART #	DESCRIPTION	QTY
1	189294	WEIGH BAR MIXER PAD 7"	4
2	872360	T-BAR W.A. 2 1/2"	4
3	860055	BAR BLOCK W.A. 2 1/2"	4
4	872239	620-16XD TRAILER FRAME	1

620-16XD STATIONARY LOAD CELL SCALE FRAME ASSEMBLY

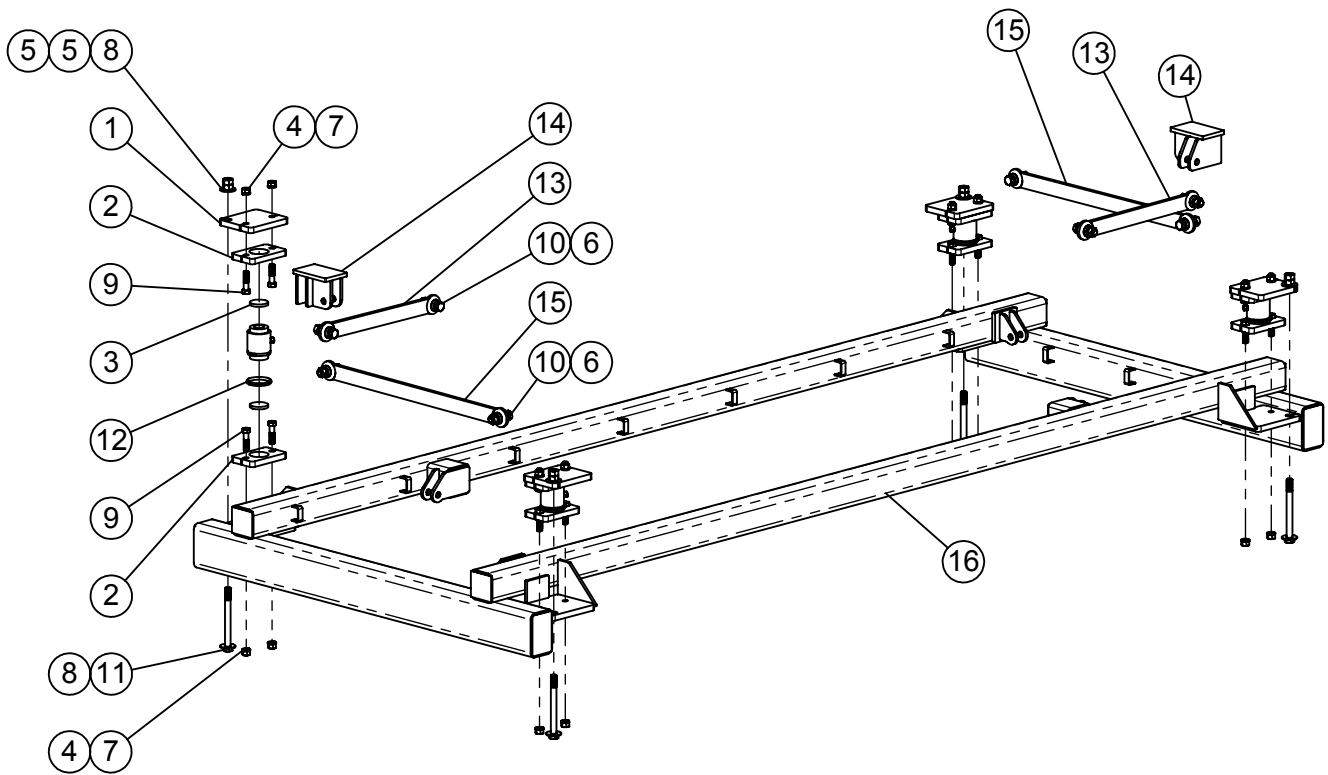

ITEM #	PART #	DESCRIPTION	QTY.
1	182881	SCALE MOUNT MIXER PLATE	4
2	182915	LOAD CELL CAGE PLATE	8
3	185997	SCALE PAD	8
4	400210	HEX NUT 5/8"-11 #5 PLTD	16
5	400212	HEX NUT 3/4"-10 #5 PLTD	8
6	400912	HEX CROWN LOCK NUT 3/4"-10 #5 PLTD	8
7	402010	SPRING LOCK WASHER 5/8" PLTD	16
8	402412	FLAT WASHER 3/4" PLTD	8
9	405756	HHCS, 5/8"-11 x 2-1/2" #5 PLTD	16
10	405783	HHCS 3/4-10 x 3" #5 PLTD	8
11	405795	HHCS #5 PLTD, 3/4"-10 x 8"	4
12	455204	DUST SEAL	4
13	870501	SCALE CHECK ROD W.A.	2
14	870519	MIXER SCALE CHECK W.A.	2
15	871053	SCALE CHECK ROD WA - 31-1/2"	2
16	872271	600 STAT SCALE FRAME WA	1

620-16XD TRAILER ASSEMBLY

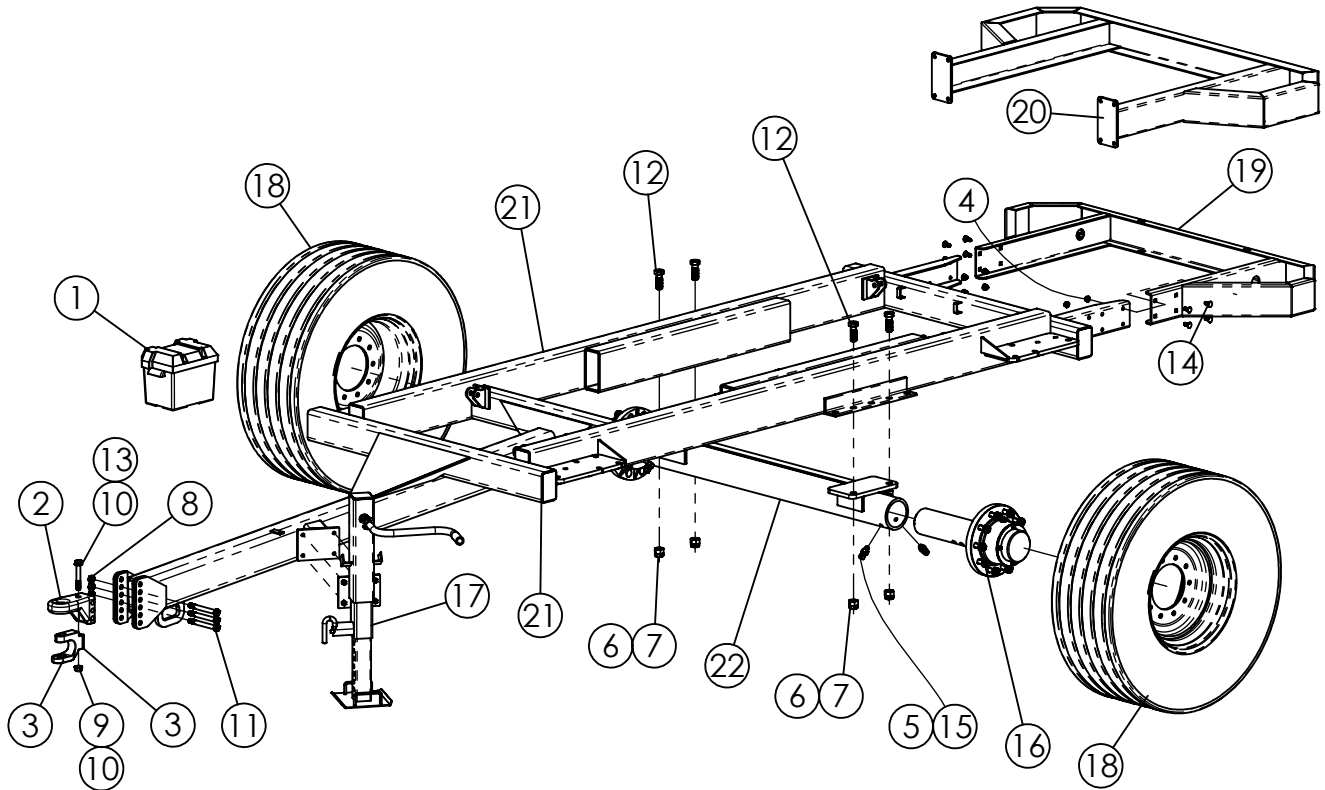

ITEM #	PART #	DESCRIPTION	QTY.
1	357400	BATTERY BOX W/STRAP	1
2	374100	CAT 3 BASE HITCH BODY (PPI-237VR)	1
3	374101	CAT 3 CLEVIS INSERT (PPI-208VR)	1
4	400114	HEX NUT, 1/2-13 SERRATED FLANGE #5	8
5	400212	HEX NUT 3/4"-10 #5 PLTD	4
6	400216	HEX NUT, 1"-8 #5 PLTD	4
7	400616	HEX JAMNUT 1"-8 #5 PLTD	4
8	400912	HEX CROWN LOCK NUT 3/4"-10 #5 PLTD	3
9	400918	HEX CROWN LOCKNUT 3/4"-10 #8 PLTD	1
10	402512	FLAT WASHER 3/4" SAE	2
11	405793	HHCS 3/4"-10 x 7" #5 PLTD	3
12	405831	HHCS 1"-8 x 3" #5 PLTD	4
13	406487	HHCS 3/4"-10 x 5" #8 Pltd	1
14	407101	CHCS 1/2"-13 x 1-1/4" #5 PLTD	8
15	409623	SQ HEAD SET SCREW 3/4" x 2"	4
16	750113	TRAILER HUB ASSY 20K GROVE (GREASE LUBED)	2
	750110-C	TRAILER HUB ASSEMBLY, 20K LB (OIL LUBED)	2
17	780699	9,000 LB DROP LEG JACK (ANGLED MOUNT)	1
18	781145	18 x 22.5 TIRE & 10 BOLT WHEEL	2
19	850564	TRAILER BUMPER WA	1
20	872238	620 TRAILER BUMPER WA	1
21	872239	620 TRL FRAME WA	1
22	872240	620 TRAILER AXLE WA	1

SINGLE AXLE TRAILER HUB & SPINDLE ASM
20,000 LB #750113, (GREASE LUBED BEARINGS)
(Used After Serial #810991539)

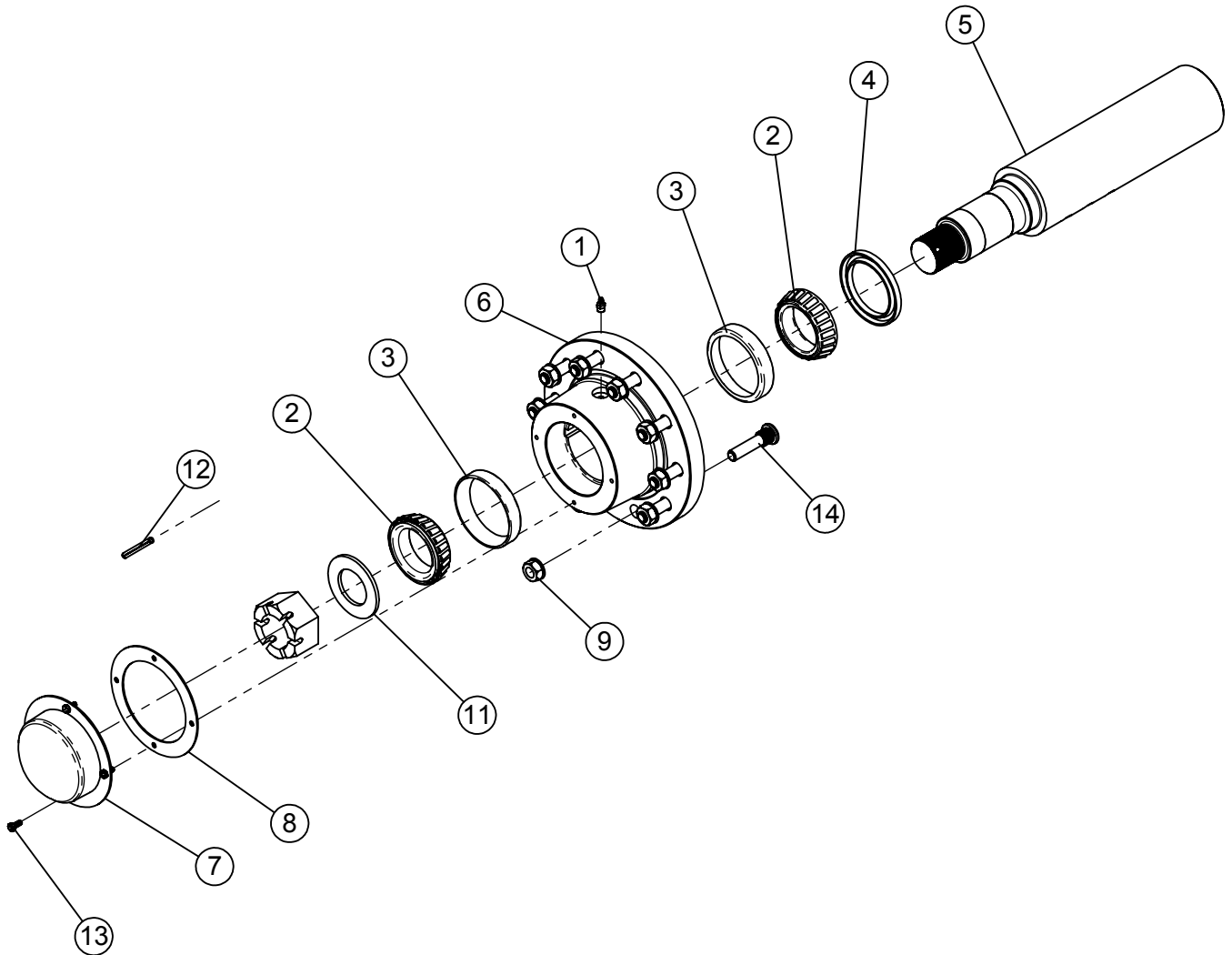

ITEM #	PART #	DESCRIPTION	QTY.
1	310750	FPT GREASE ZERK PLTD 1/8	1
2	342223	CONE, 3.25 BORE TIM #47687	2
3	342224	RACE 5.25 OD TIM #47620	2
4	355058	SEAL - 3 7/8" I.D. CR 38731	1
5	372013	SPINDLE, 20K 4.9375" x 25.5"	1
6	372214	HUB, 10 BOLT ON 11.25BC 20K	1
7	372325	DUST CAP, 20K GROVE HUB	1
8	372326	GASKET, 20K HUB CAP	1
9	400131	NUT, SWIVEL FLANGE LUG 3/4"-16	10
10	401833	2-1/2"-12 HEX CSTL NUT SAE	1
11	402913	WASHER, 4.5"ODx 2.625ID x.25 THK	1
12	404134	ROLL DRIVE PIN 3/8"x3-1/2"	1
13	405627	HHCS #5 PLTD 5/16"X 3/4"	4
14	407732	STUD BOLT 3/4"-16 x 3-1/2"OAL	10

SINGLE AXLE TRAILER HUB & SPINDLE ASM
20,000LB. #750010-C (OIL LUBED BEARINGS)
 (Used prior to Serial #810991539)

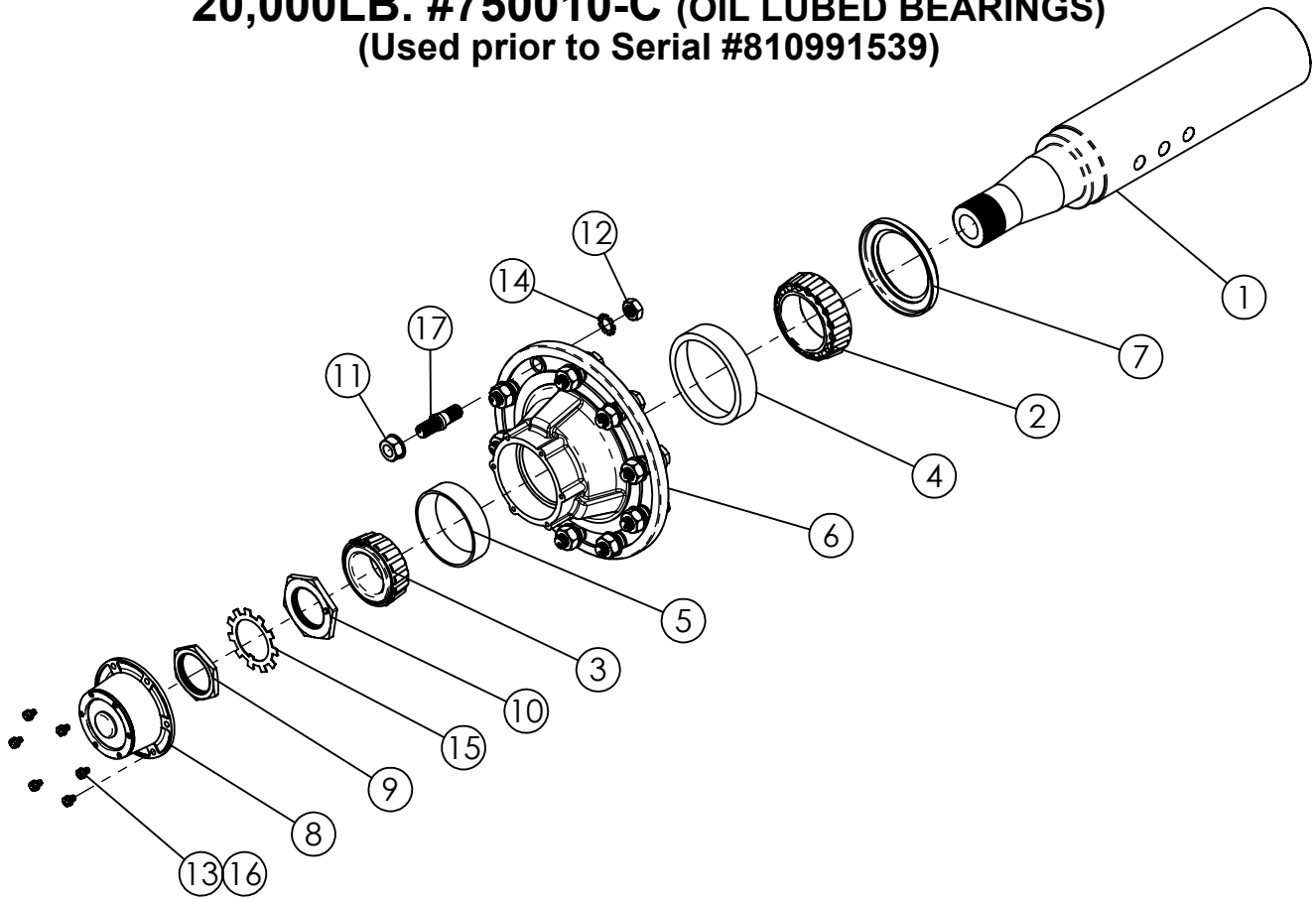

ITEM #	PART #	DESCRIPTION	QTY.
1	184614	SPINDLE, 20,000#	1
2	342213	INNER BEARING 3.543" BORE	1
3	342214	OUTSIDE BEARING 2-5/8" OD	1
4	342215	INNER BEARING RACE 5.787"OD	1
5	342216	OUTSIDE BEARING RACE 4-13/16" OD	1
6	372212	10-BOLT HUB ASSEMBLY, (RIGHT HAND) 20,000#	1
7	372304	SEAL 4-3/8" BORE	1
8	372309	DUST CAP, 20,000# HUB	1
9	400033	OUTER NUT, 3/8" THICK x 2-5/8" ID	1
10	400034	INNER NUT, 3/8" THICK x 2-5/8" ID	1
11	400131	NUT, SWIVEL FLANGE LUG 3/4"-16	10
12	400712	HEX JAM NUT 3/4"-16	10
13	402005	WASHER 5/16", SPRING LOCK, MED PLTD	6
14	402112	LOCK WASHER, EXTERNAL STAR 3/4"	10
15	402904	LOCKING WASHER 1/4" THICK x 2-41/64" ID	1
16	405625	HHCS 5/16"-18 x 1/2" #5 PLTD	6
17	407724	STUD BOLT RH 3/4"-16	10

620-16XD OIL BATH DOOR ASSEMBLY

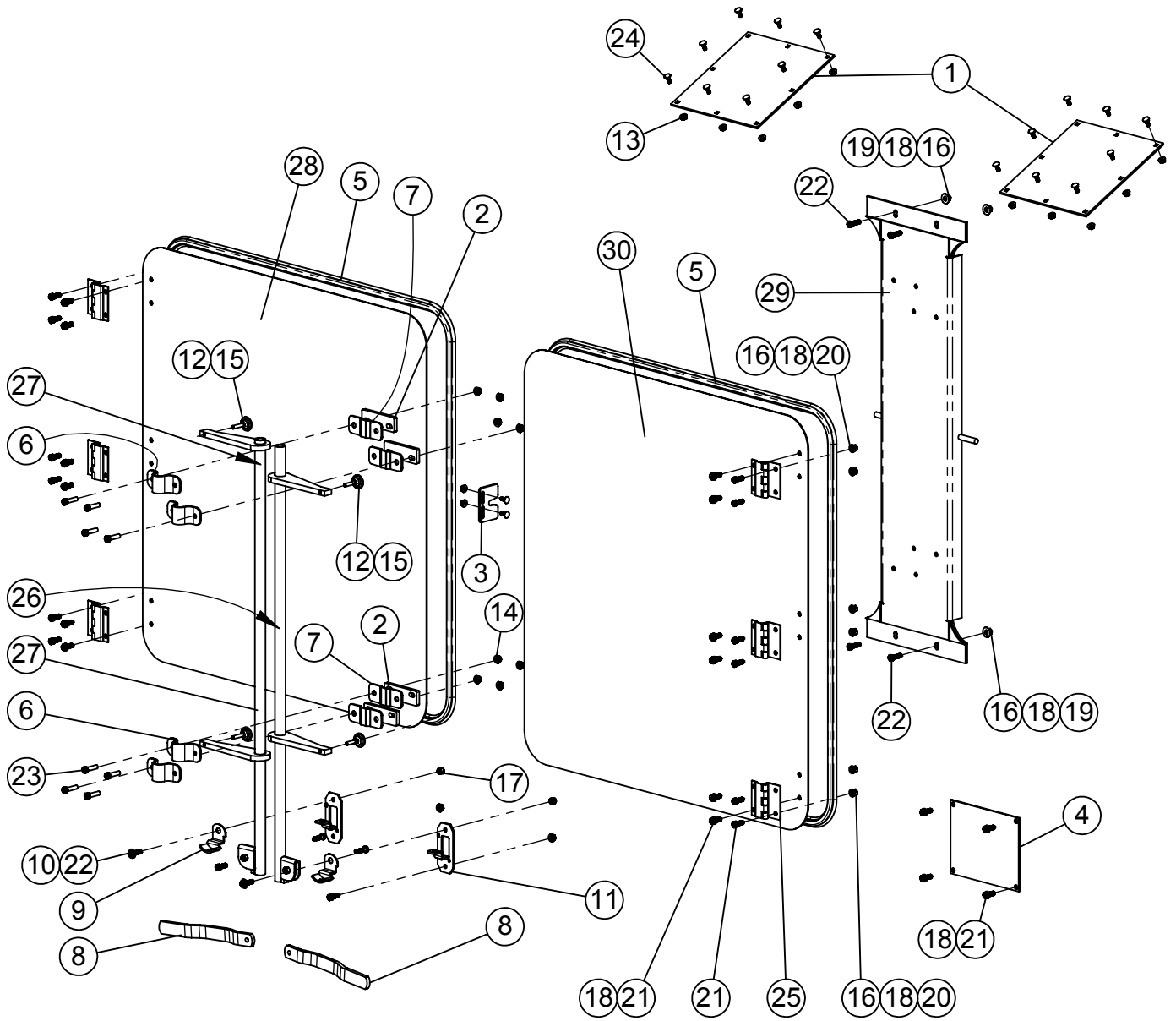

620-16XD OIL BATH DOOR ASSEMBLY

ITEM #	PART #	DESCRIPTION	QTY.
1	185219	OIL BATH TOP DOOR 12" x 12"	2
2	189503	CAM ROD SPACER	4
3	190713	OB DOOR SUPPORT PLATE - WIDE	2
4	190776	INSPECTION HOLE COVER 7-1/2" x 9-1/2"	1
	192347	INSPECTION HOLE COVER 12-1/4" x 12-1/4"	
5	351056	RUBBER BULB SEAL 5/32"	2
6	370316	CAM LOCK TOP PLATE	4
7	370317	CAM LOCK BOTTOM PLATE	4
8	370319	CAM LOCK HANDLE	2
9	370320	HANDLES CAM LOCK	2
10	370321	CAM LOCK BUSHING	2
11	370322	HANDLE STOP	2
12	370323	LEVELING PAD	4
13	400106	HEX NUT, 5/16"-18 SER. FLANGE #5 PLTD	20
14	400107	HEX NUT, 3/8"-16 SERRATED FLANGE #5	10
15	400205	HEX NUT 5/16"-18 #5 PLTD	4
16	400206	HEX NUT 3/8"-16 #5 PLTD	16
17	401106	HEX NUT, 3/8"-16 NYLOC #5 PLTD	4
18	402006	WASHER SPRING LOCK 3/8" MED PLTD	32
19	402406	FLAT WASHER 3/8" PLTD	4
20	402506	FLAT WASHER 3/8" SAE PLTD	12
21	405653	HHCS 3/8"-16 x 1" #5 PLTD	30
22	405654	HHCS 3/8"-16 x 1-1/4" #5 PLTD	8
23	405655	HHCS 3/8"-16 x 1 1/2" #5 PLTD	8
24	407020	CHCS 5/16"-18 x 3/4" #5 PLTD	20
25	410219	HINGE, OFFSET, 3 1/2" SQ	6
26	850574	420/490 RH CAM LOCK WA	1
27	850575	420/490 LH CAM LOCK WA	1
28	872618	620 OB DOOR WA	1
29	872639	620 OB CENTER CHANNEL WA	1
30	872985	620 OIL BATH DOOR WA RH SIDE	1

620-16XD ROTO-HAY PROCESSOR ASSEMBLY

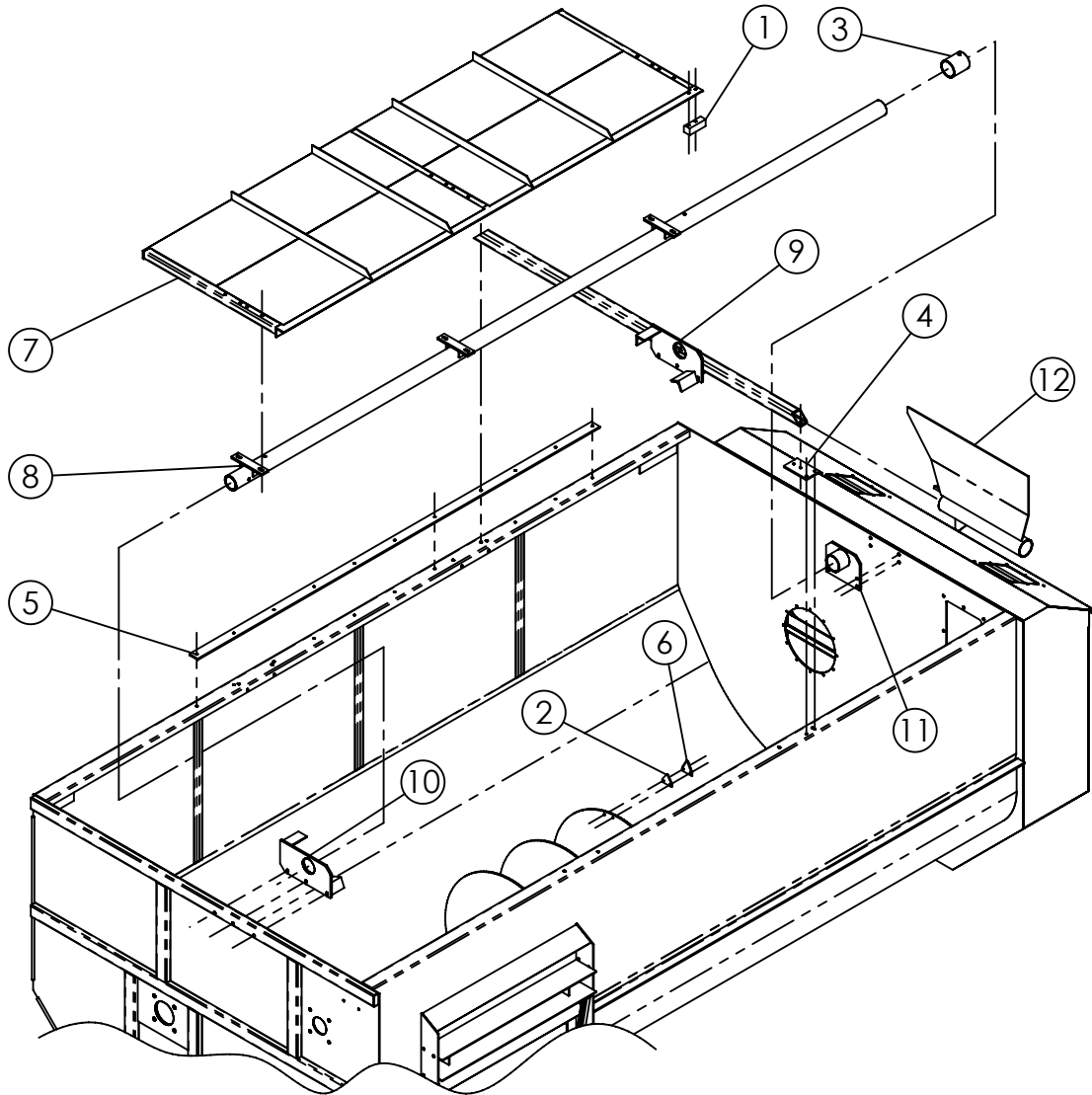

REF #	PART #	DESCRIPTION	QTY.
1	150198	BAFFLE PLUNGER	1
2	150223	KNIFE BACKUP PLATE	56
3	189127	HAY TUBE SLEEVE RETAINER	1
4	189128	CROSS BAR PLATE	1
5	189150	SIDE REINFORCEMENT BAR	1
6	385002	KNIFE SECTION - HARD SURFACED	56
7	872351	620 HAY PAN W.A.	1
8	872358	HAY PAN TUBE W.A.	1
9	872675	HAY PAN CROSS BAR W.A.	1
10	872676	HAY PAN FRONT BEARING W.A.	1
11	872677	HAY PAN REAR BEARING W.A.	1
12	872678	HAY PAN BAFFLE W.A.	1

620-16XD HAY PROCESSOR ASSEMBLY (CABLE OPTION)

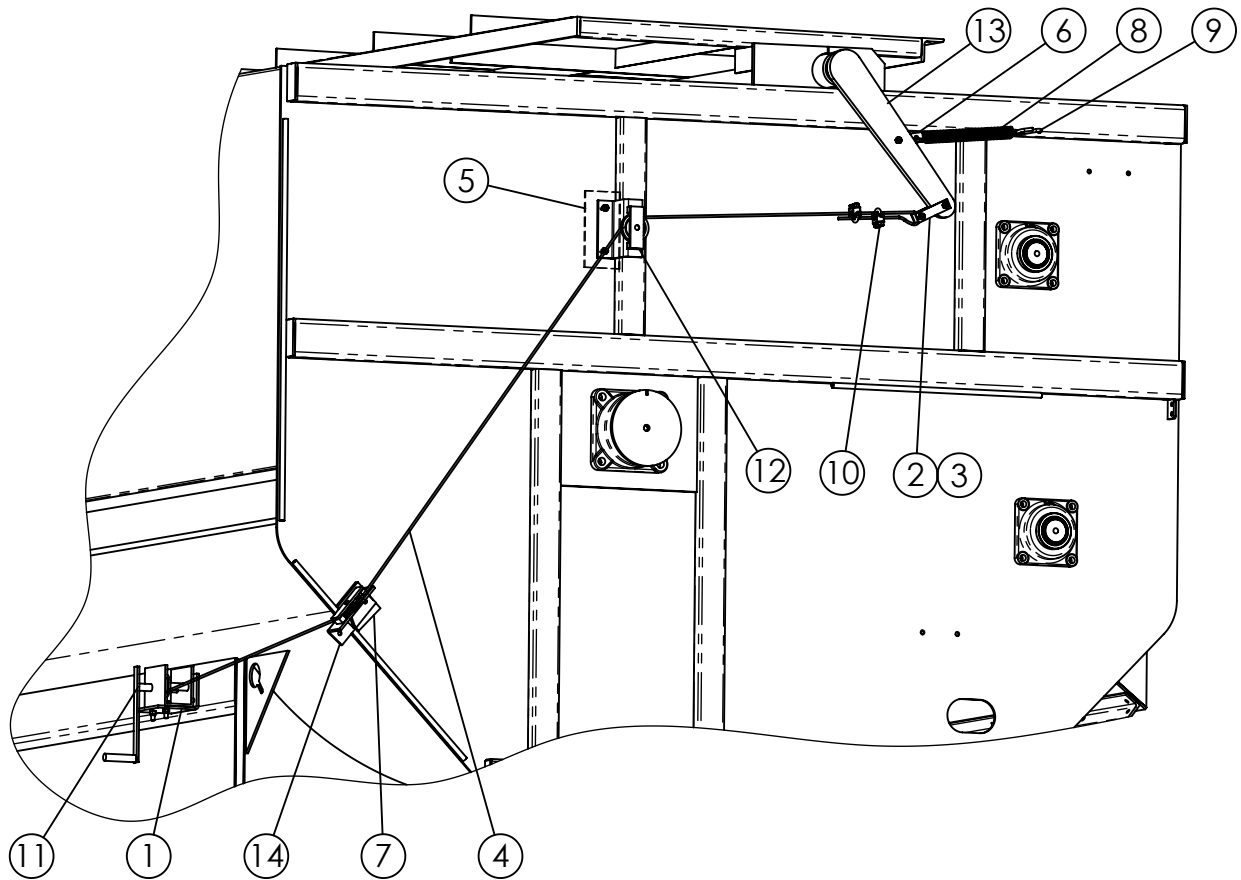

ITEM #	PART #	DESCRIPTION	QTY.
1	150186	CABLE WINCH MNT PLT-6	1
2	150188	CABLE BAR - 4"	2
3	150189	SLEEVE - 13/16"	1
4	150279	HAY PAN CABLE 13FT	1
5	150288	PULLY BACK - UP PLATE - 4"	1
6	150391	SPRING PULL BAR - 4"	1
7	189718	PULLY BRACKET SPACER	1
8	410009	PULL SPRING, 1 1/4" X 14"	1
9	411805	S - HOOK, 5/16"	1
10	412204	CABLE CLAMP, 1/4", PLTD	2
11	412325	WINCH, 1000 LB. CABLE BRAKE	1
12	850066	CABLE PULLY BRKT W.A.	1
13	850090	HAY PAN CABLE ARM W.A.	1
14	850105	CORNER PULLY BRKT W.A.	1

620-16XD HAY PROCESSOR ASSEMBLY (HYDRAULIC OPTION)

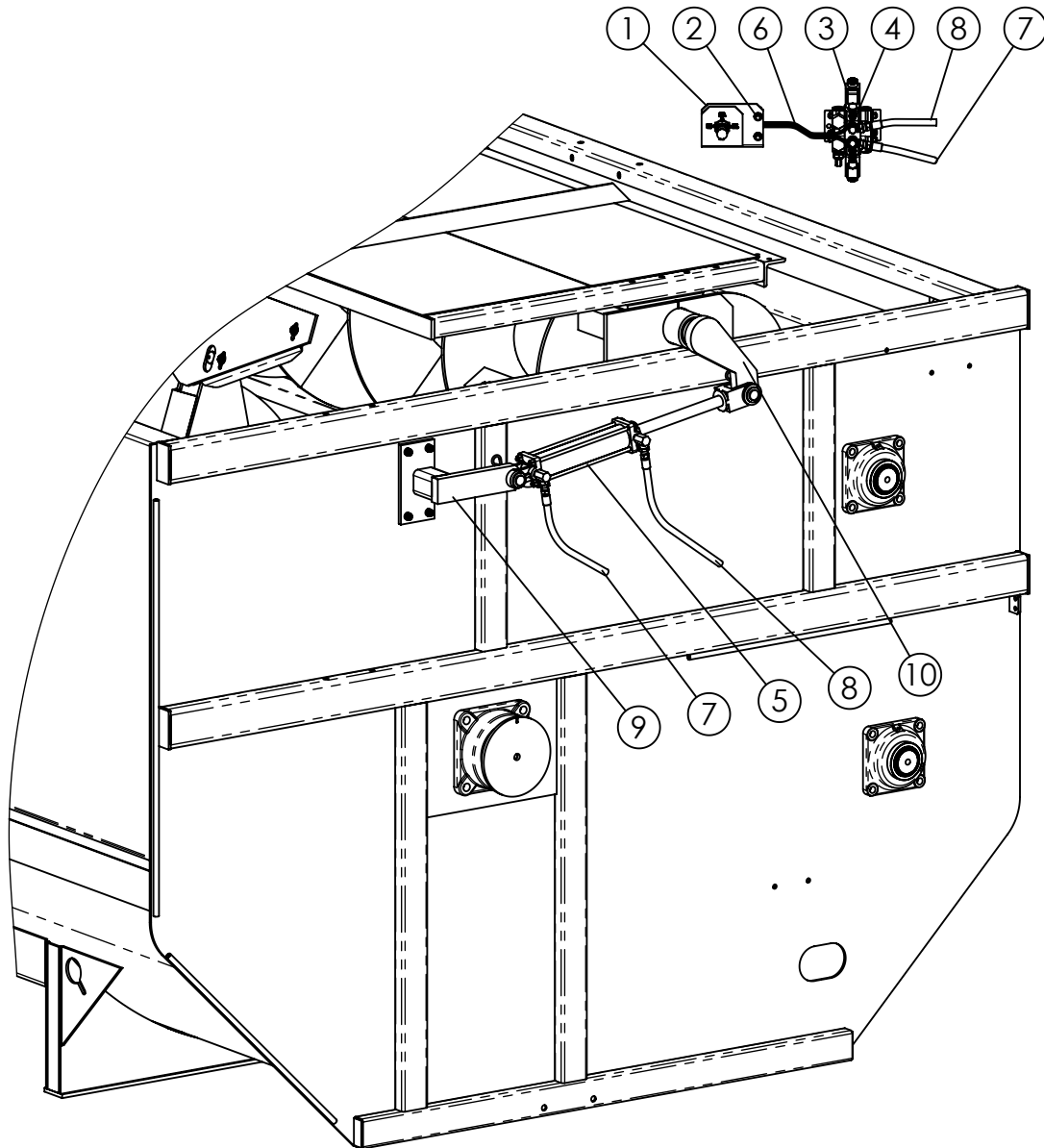

ITEM #	PART #	DESCRIPTION	QTY.
1	188226	FEEDER ELECTRIC CONTROL BRACKET 5 1/4" x 6"	1
2	357702	SWITCH, 12V-2 POLE PUSH BUTTON	2
3	362206	HYD VALVE 12V SINGLE, BUCHER	1
4	368030	HYD SWIVEL 9/16" MOR x 3/8" FPS 90°	2
5	780109	CYLINDER ASSY 2" x 8"	1
6	781055	TRUCK TO MIXER WIRE ASSEMBLY	1
7	781070	HOSE ASSEMBLY, 3/8" x 87", 3/8" MP ENDS	1
8	781097	HOSE ASSEMBLY, 3/8" x 68", 3/8" MP ENDS	1
9	872679	HAY PAN CYLINDER BRACKET WA	1
10	872698	620 HAY PAN HYDRAULIC LEVER ARM W.A.	1

620-16XD CROSS OVER BAR & HAY SHEAR BAR

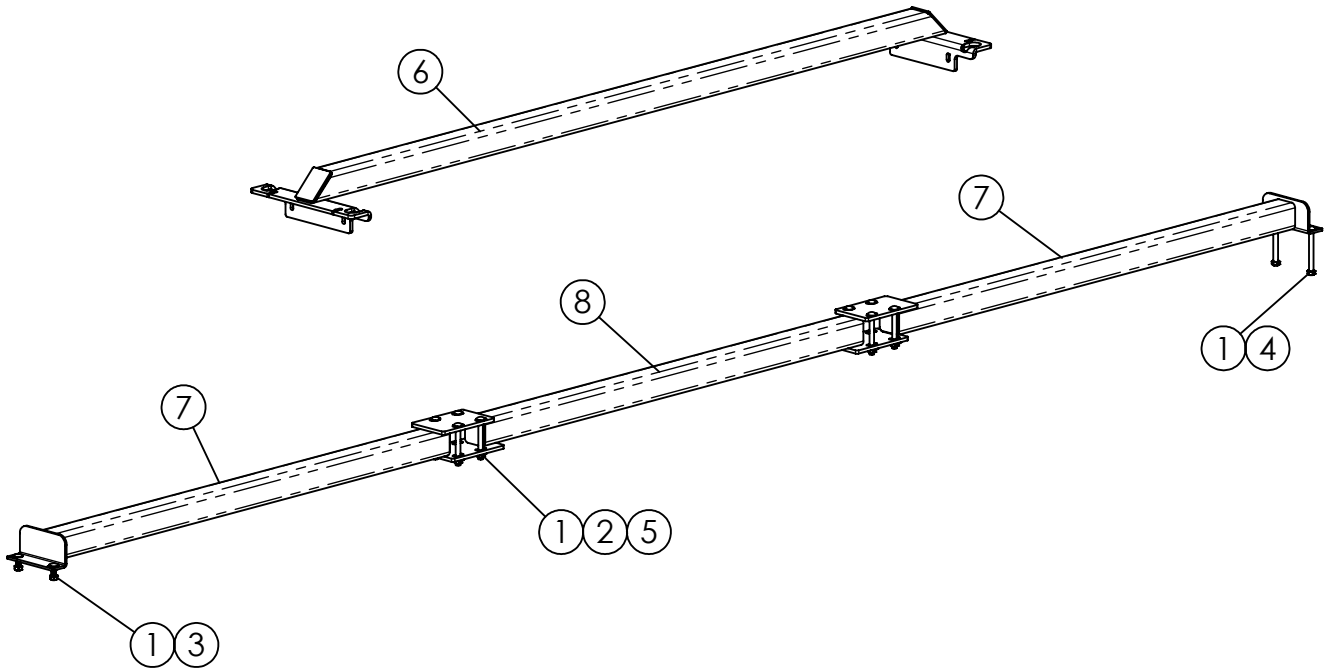

ITEM #	PART #	DESCRIPTION	QTY
1	400908	HEX CROWN LOCNUT 1/2"-13 #9	12
2	402408	WASHER, FLAT 1/2" MED PLTD	8
3	407101	CHCS 1/2"-13 x 1-1/4" #5 PLTD	2
4	407112	CHCS 1/2"-13 x 5" #5 PLTD	2
5	407113	CHCS 1/2"-13 x 4-1/2" #5 PLTD	8
6	872638	620 CROSS OVER BAR W.A.	2
7	873164	620/720 HAY SHEAR TUBE WA END	2
8	873165	620/720 HAY SHEAR TUBE WA CTR	1

620-16 FENDERS & MUD FLAPS

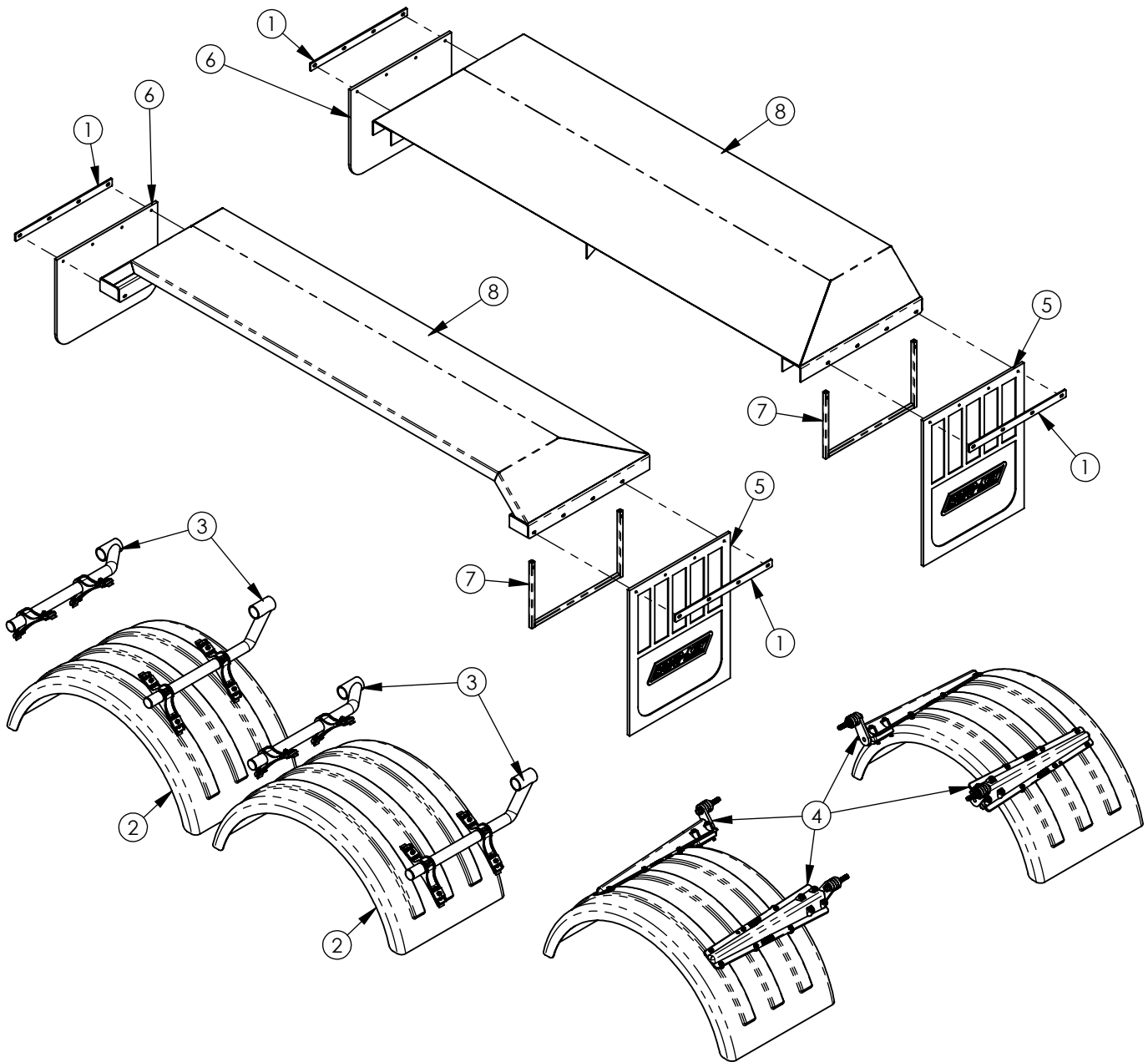

REF #	PART #	DESCRIPTION	QTY
1	183087	MUD FLAP STRAP	4
2	354391	POLY FENDER	3
3	354392	POLY FENDER TUBING MOUNT KIT (2 per kit)	2
4	354393	POLY FENDER TAPER BRACKET KIT (4 per kit)	1
5	370200	ROTO-MIX MUD FLAP 24" x 30"	2
6	370202	ROTO-MIX MUD FLAP 24" x 18-1/2"	2
7	872120	MUD FLAP BRACKET WA	2
8	872130	TANDEM FENDER WA	2

620-16XD OIL BATH LUBE ASSEMBLY COPPER TUBING LINES

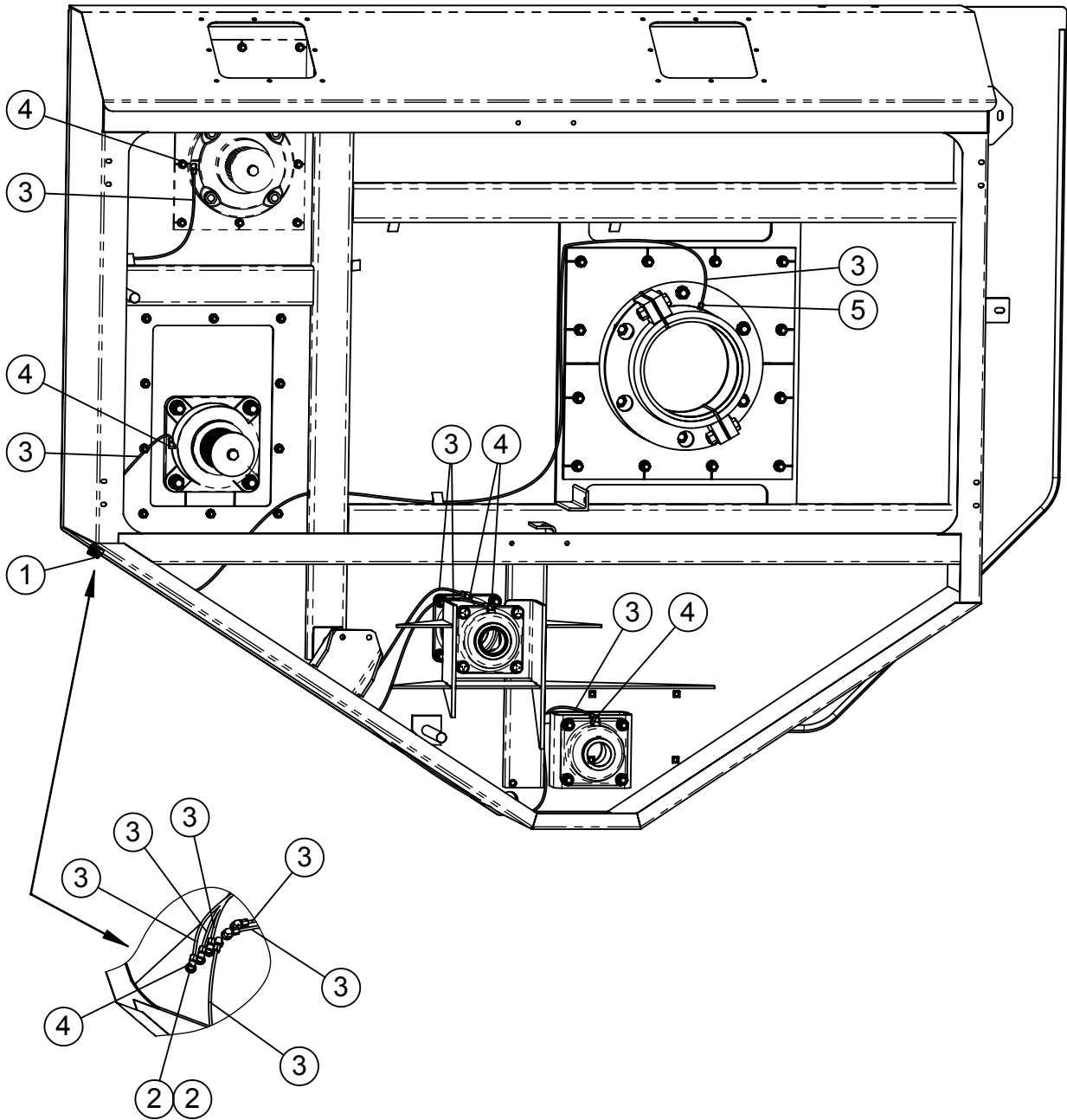

ITEM #	PART #	DESCRIPTION	QTY.
1	310750	GREASE ZERK PLTD 1/8"	6
2	402506	FLAT WASHER 3/8" SAE PLTD	12
3	356203	COPPER TUBING, 3/8" SAE PLTD	6
4	356001	COMPRESSION FITTING 1/8"MP x 3/16", 90°	11
5	356002	COMPRESSION FITTING 1/8" MP x 3/16" STRAIGHT	1

620-16XD OIL BATH LUBE ASSEMBLY HOSE LINES

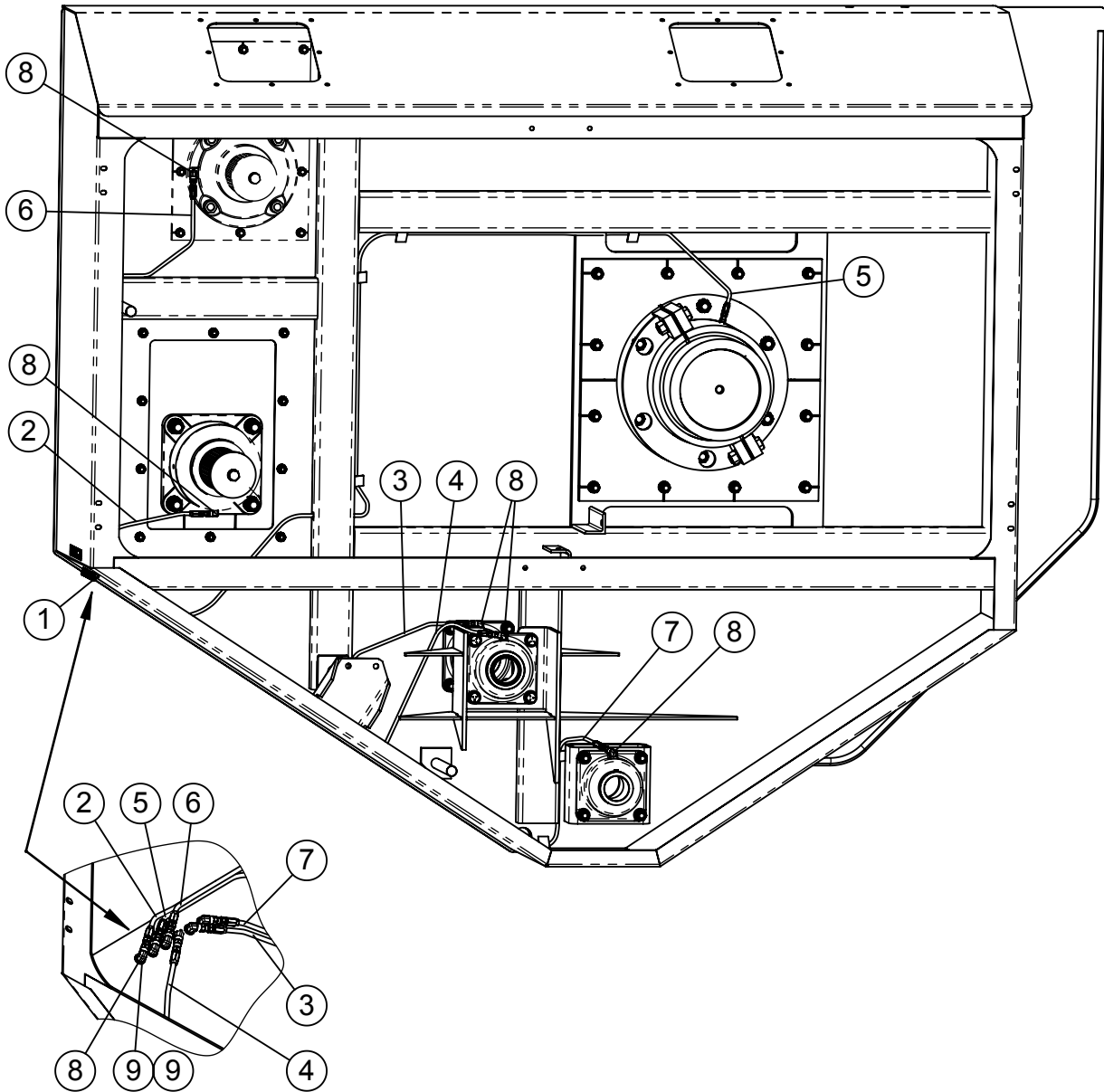

ITEM #	PART #	DESCRIPTION	QTY.
1	310750	GREASE ZERK PLTD 1/8"	6
2	367524	GREASE LINE (FILLED) 23" LG	1
3	367525	GREASE LINE, (FILLED) 51" LG	1
4	367525	GREASE LINE, (FILLED) 51" LG	1
5	367526	GREASE LINE, (FILLED) 113 "LG	1
6	367527	GREASE LINE (FILLED) 61 "LG	1
7	367528	GREASE LINE, (FILLED) 71" LG	1
8	368000	PIPE ELBOW, 90° STREET 1/8"MP x 1/8"FP	11
9	402506	FLAT WASHER 3/8" SAE PLTD	12

620-16XD FRONT END SHEET LUBE ASSEMBLY

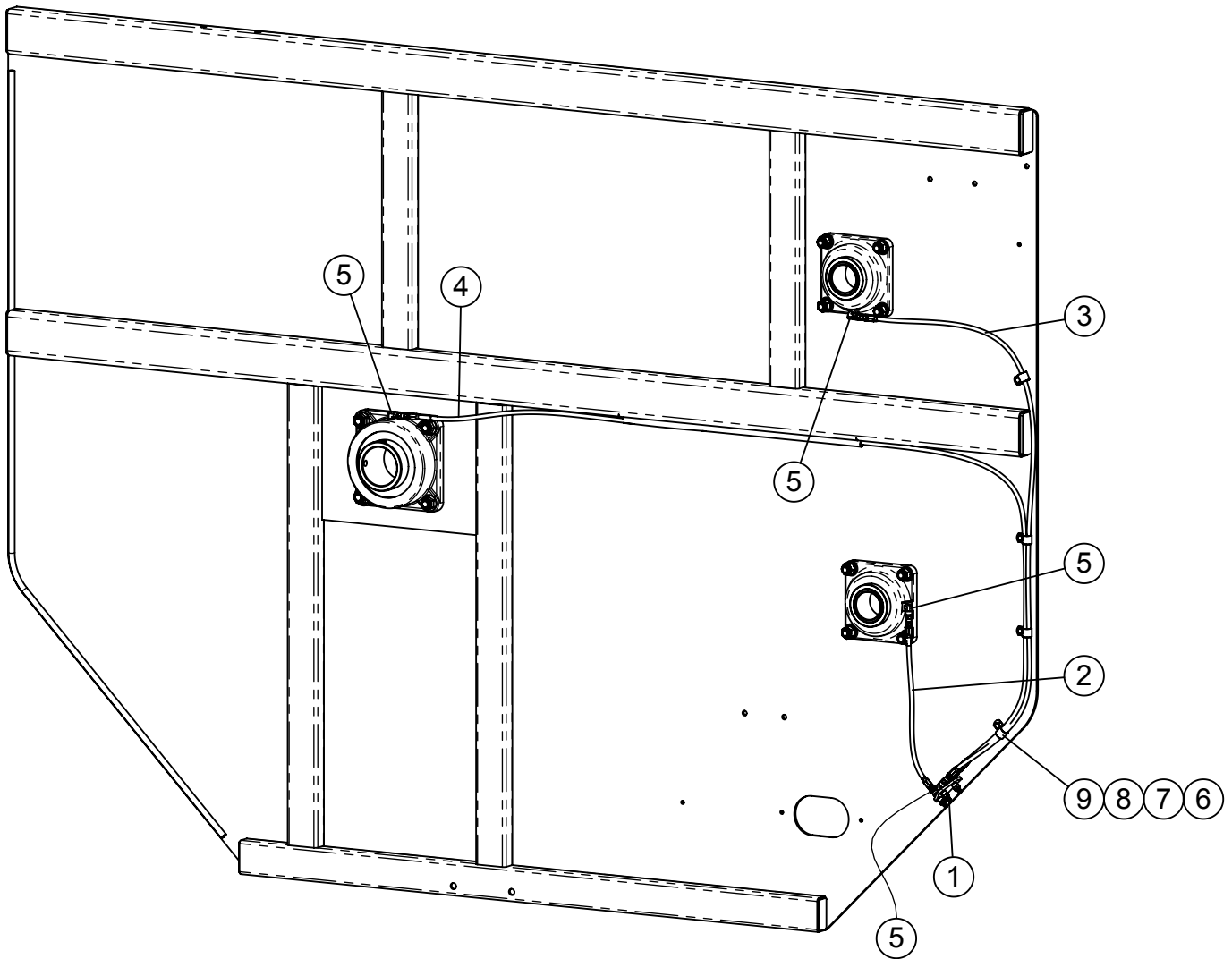

ITEM #	PART #	DESCRIPTION	QTY.
1	310750	GREASE ZERK PLTD 1/8"	3
2	367521	GREASE LINE, (FILLED) 14" LG	1
3	367522	GREASE LINE, (FILLED) 55" LG	1
4	367523	GREASE LINE, (FILLED) 88" LG	1
5	368000	PIPE ELBOW, 90° STREET 1/8"MP x 1/8"FP	5
6	400204	HEX NUT 1/4"-20 #5 PLTD	3
7	402004	WASHER, SPRING LOCK 1/4" PLTD	3
8	405602	HHCS 1/4" -20 x 3/4" USS #5 PLTD.	3
9	455400	TUBE CLAMP, 3/4" DIA.	4

LADDER OPTIONS AVAILABLE

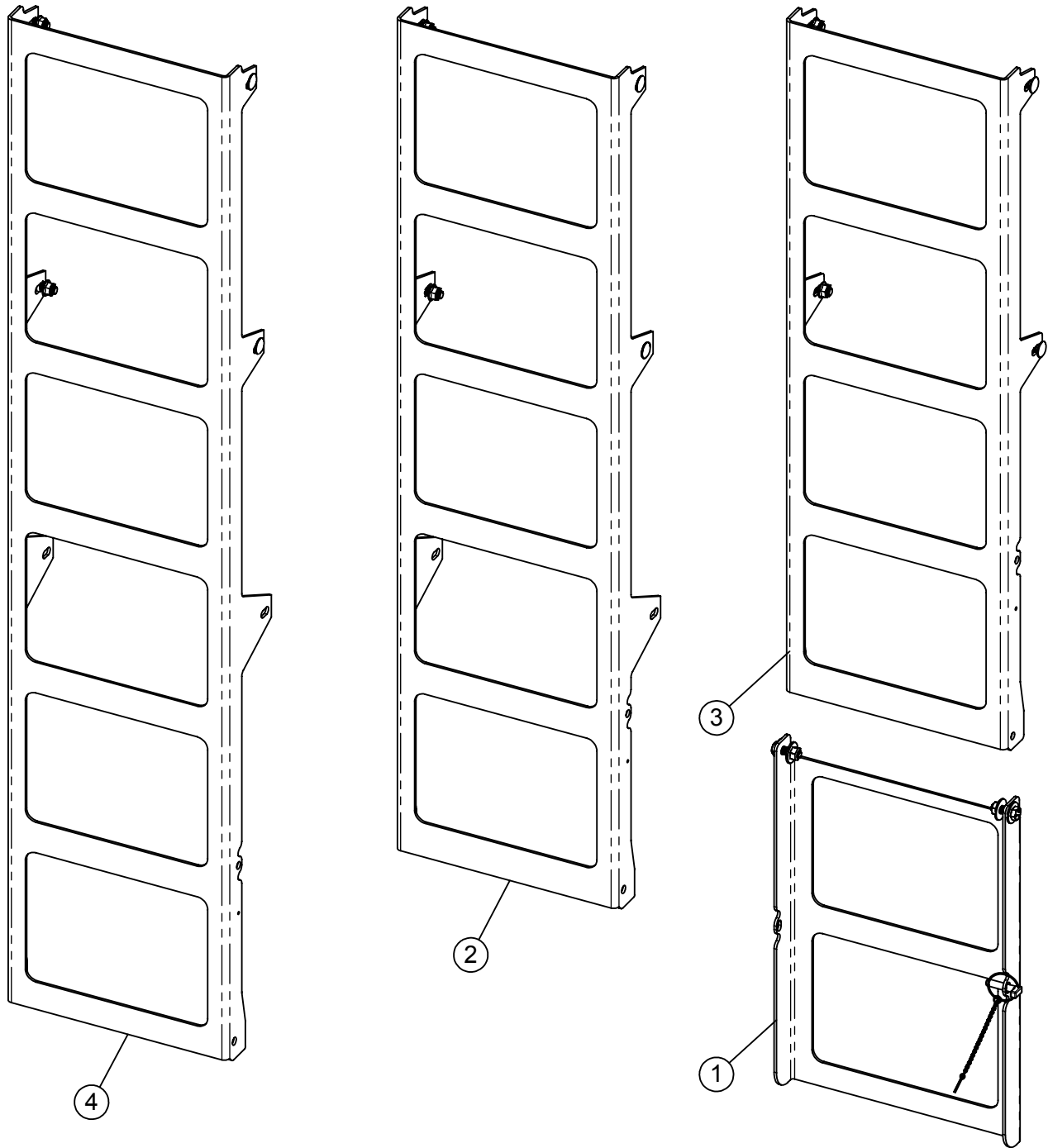

ITEM #	PART #	DESCRIPTION	QTY.
1	780095	LADDER BUNDLE, (2 RUNG EXTN)	1
2	780288	LADDER BUNDLE, (6 RUNG)	1
3	780289	LADDER BUNDLE, (5 RUNG)	1
4	780906	LADDER BUNDLE, (7 RUNG)	1

TRUCK CAB SCALE INDICATOR FRAME PARTS

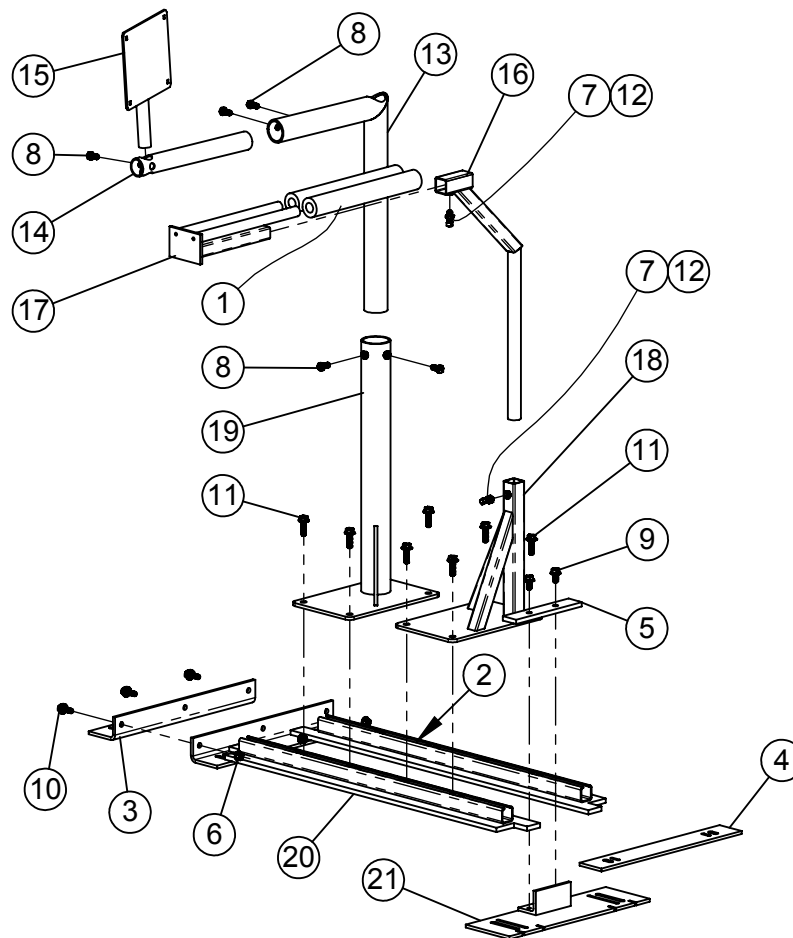

ITEM #	PART #	DESCRIPTION	QTY.
1	185930	ARM REST PAD 12"	2
2	192578	ARM REST SLIDE BAR	4
3	192585	BRACKET, PASSENGER CAB SEAT	1
4	192587	SPACER, TRUCK CAB DRIVER'S SEAT	1
5	192593	PLATE, TRUCK CAB MOUNT SETTING	1
6	400107	HEX NUT, 3/8"-16 SERRATED FLANGE #5	3
7	400606	HEX JAM NUT 3/8-16"	2
8	405652	HHCS 3/8"-16 x 3/4" #5 PLTD	5
9	407900	HHCS 3/8"-16 x 3/4" SERRATED #5 PLTD	2
10	407901	HHCS 3/8"-16 X 1" SERRATED #5 PLTD	3
11	407904	HHCS 3/8"-16 x 1-1/4" SERRATED #5 PLTD	8
12	409543	SQ HD SET SCREW CUP, 3/8" x 1"	2
13	871095	TRUCK SCALE INDICATOR MOUNT W.A.	1
14	871103	INDICATOR EXTENSION TUBE W.A.	1
15	871111	TRUCK SCALE INDICATOR SWIVEL W.A.	1
16	872263	ARM REST GOOSE NECK W.A.	1
17	872264	ARM REST W.A.	1
18	873389	SHORT ARM REST STAND W.A.	1
19	873390	SHORT TRUCK SCALE IND. BASE W.A.	1
20	873391	BASE, TRUCK CAB MOUNT WA	1
21	873394	BRACKET, DRIVER'S SEAT WA	1

620-16XD SHELL REPAIR PARTS

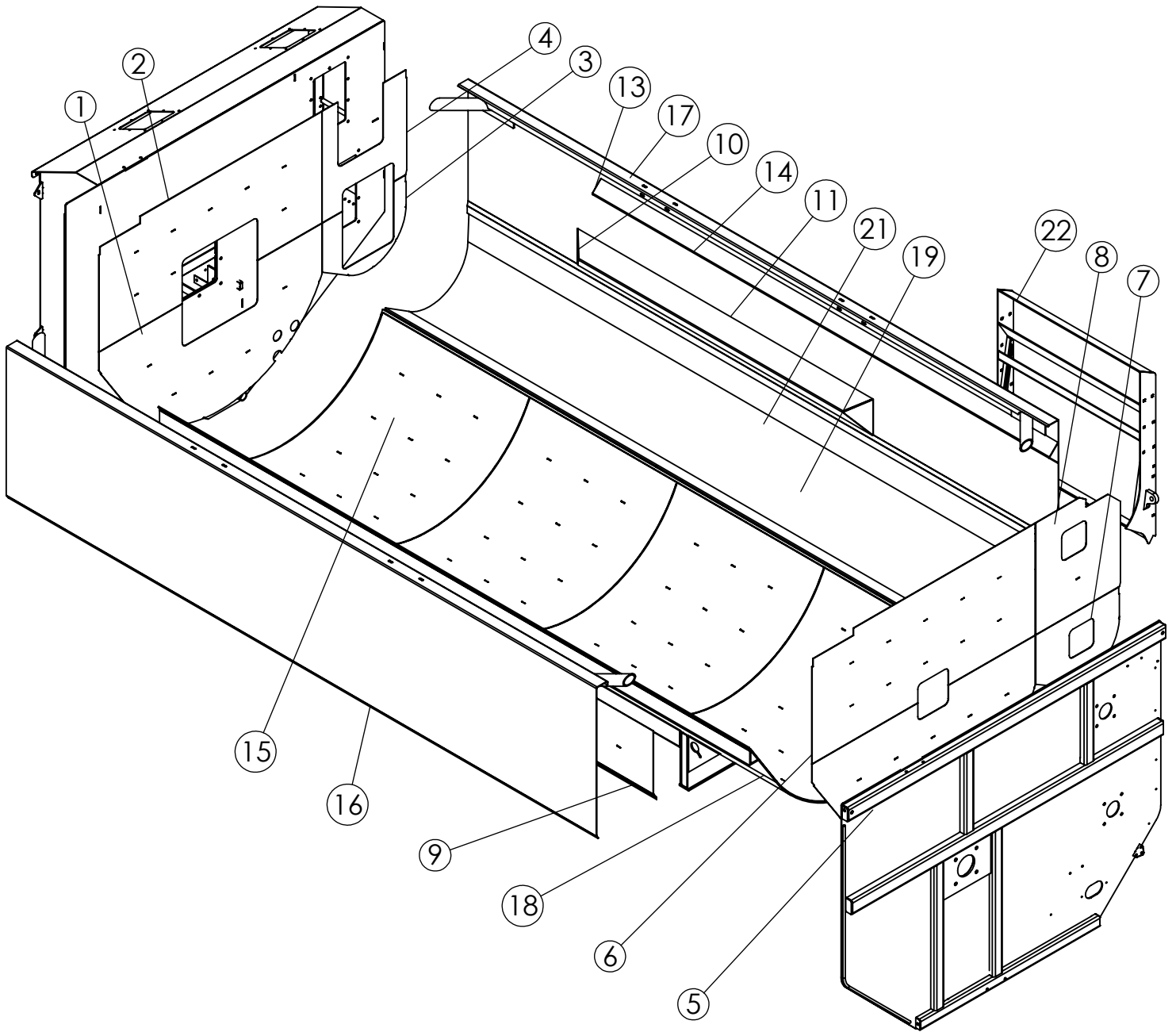

620-16XD SHELL REPAIR PARTS

ITEM#	PART#	DESCRIPTION	QTY.
1	186290-C	LINER, 620 RR BTM END (NYL) SS 10 GA	1
	186290-D	LINER, 620 RR BTM END (NYL) 7GA MS	
2	186291-C	LINER, 620 RR UPR END (NYL) 10GA SS	1
	186291-D	LINER, 620 RR UPR END (NYL) 7GA MS	
3	186292-C	LINER, 620 RR BTM AUGER END NYL 10GA SS	1
	186292-D	LINER, 620 RR BTM AUGER END NYL 7GA MS	
4	186293-C	LINER, 620 RR UPPER AUGER NYL 10GA SS	1
	186293-D	LINER, 620 RR UPPER AUGER NYL 7GA MS	
5	186294-C	LINER, 620 FRT BTM TUB NYL 10GA SS	1
	186294-D	LINER, 620 FRT BTM TUB NYL 7GA MS	
6	186295-C	LINER, 620 FRT UPR TUB END NYL 10GA SS	1
	186295-D	LINER, 620 FRT UPR TUB END NYL 7GA MS	
7	186296-C	LINER, 620 FRT BTM AUGER NYL 10GA SS	1
	186296-D	LINER, 620 FRT BTM AUGER NYL 7GA MS	
8	186297-C	LINER, 620 FRT UPPR AUGER NYL 10GA SS	1
	186297-D	LINER, 620 FRT UPPR AUGER NYL 7GA MS	
9	186334-C	620 HALF RIGHT SIDE LINER 10GA SS	4
10	189456	ANGLE END CAP 6 15/16" x 10"	2
11	189659	620 AUGER ANGLE 14" x 95 3/4"	1
12	189660	SIDE SUPPORT TUBE, 620	3
13	189671	GUSSET END CAP 4" x 4" x 7 GA	1
14	189672	620 UPPER HAY ANGLE 8" x 148 1/2"	1
15	189675-C	LINER, 620 10GA SS TUB, 48x96	4
	189675-D	LINER, 620 7GA MS TUB, 48x96	
16	189767	620 RH SIDE SHEET 48 x 191-13/16	1
17	189768	620 AUGER SIDE SHEET	1
18	189769	620 - 1/4" TUB BOTTOM 191 15/16"	1
19	189772	620 - 3/8" AUGER BTM - 191 15/16"	1
20	189794	620 TUB SUPPRORT ANGLE 127 1/4"	1
21	190018-C	620 AUGER LINER 10-GA SS	2
	190018-D	620 AUGER LINER 7-GA MS	
22	873135	620 SLIDE DOOR FRAME (NEW)	1

TRUCK FRONT BUMPERS

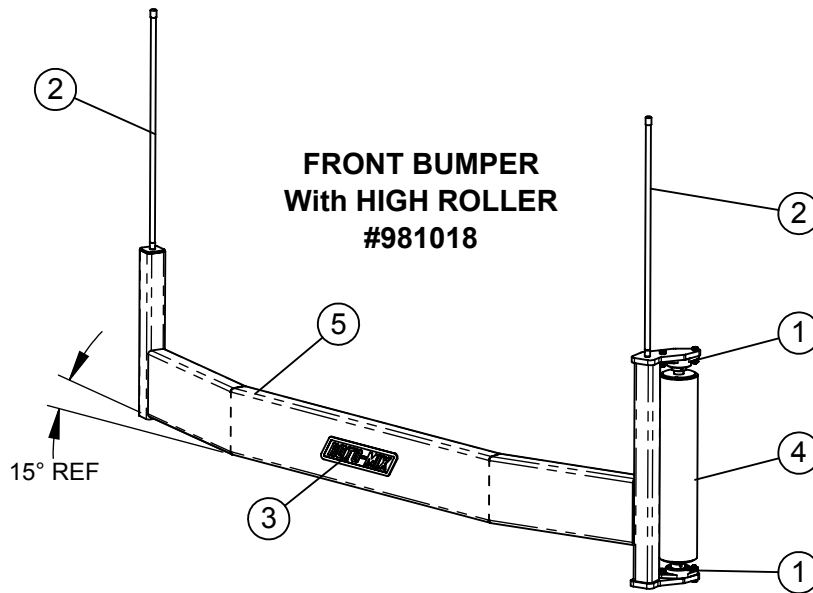

ITEM #	PART #	DESCRIPTION	QTY.
1	340222	BEARING, 1 3/8" VCJT	2
2	370334	MARKER, ORANGE STICK x 2 FT	2
3	440890	DECAL - ROTO-MIX - 15-11/16" x 3 11/16"	1
4	872434	ROLLER, FT BUMPER, 5" DIA.	1
5	872439	BUMPER FRT W/HIGH ROLLER WA.	1

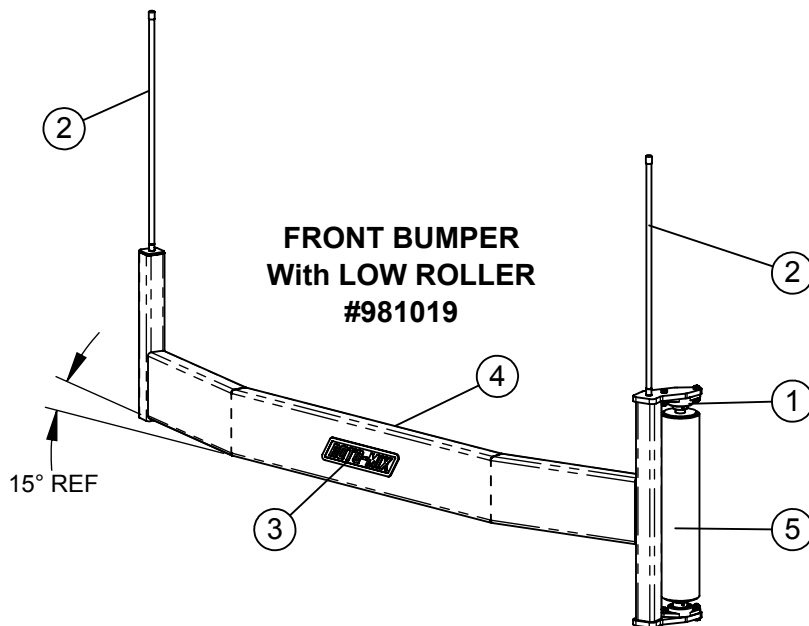

ITEM #	PART #	DESCRIPTION	QTY.
1	340222	BEARING, 1 3/8" VCJT	2
2	370334	MARKER, ORANGE STICK x 2 FT	2
3	440890	DECAL - ROTO-MIX - 15-11/16" x 3 11/16"	1
4	872430	BUMPER W/ ROLLER RR PTO WA	1
5	872434	ROLLER, FT BUMPER, 5" DIA.	1

TRUCK FRONT BUMPERS

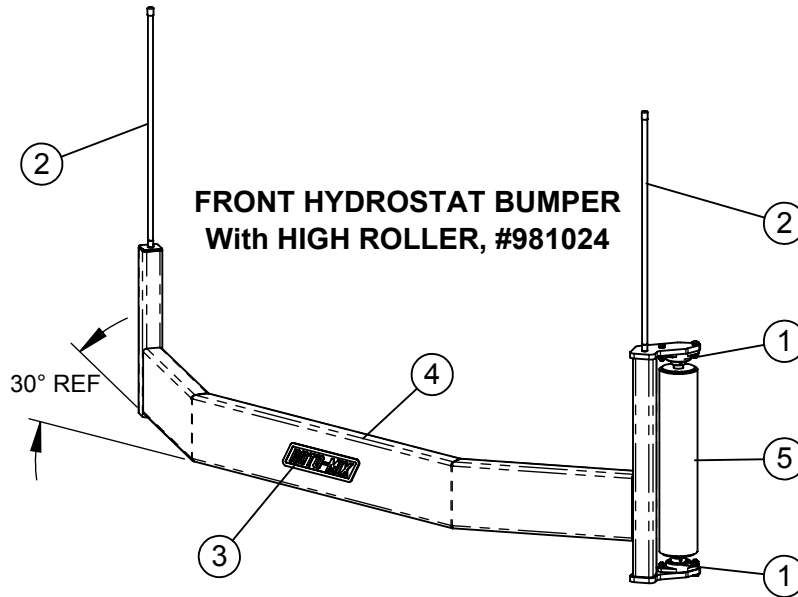

ITEM #	PART #	DESCRIPTION	QTY.
1	340222	BEARING, 1 3/8" VCJT	2
2	370334	MARKER, ORANGE STICK x 2 FT	2
3	440890	DECAL - ROTO-MIX - 15-11/16" x 3 11/16"	1
4	872431	BMPR FRT HYDRO W/HIGH RLLR WA	1
5	872434	ROLLER, FT BUMPER, 5" DIA.	1

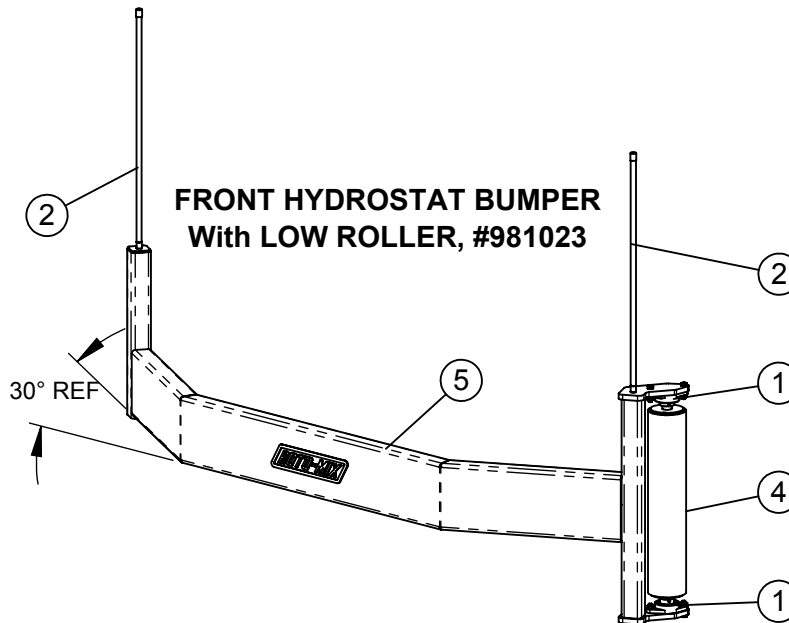

ITEM #	PART #	DESCRIPTION	QTY.
1	340222	BEARING, 1 3/8" VCJT	2
2	370334	MARKER, ORANGE STICK x 2 FT	2
3	440890	DECAL - ROTO-MIX - 15-11/16" x 3 11/16"	1
4	872434	ROLLER, FT BUMPER, 5" DIA.	1
5	872440	BMPR FRT HYDRO W/ ROLLER WA	1

TRUCK FRONT BUMPERS

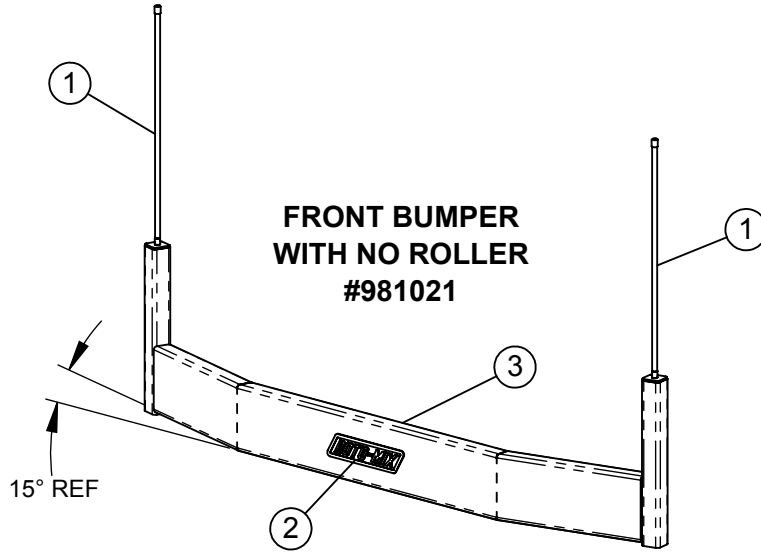

ITEM #	PART #	DESCRIPTION	QTY.
1	370334	MARKER, ORANGE STICK x 2 FT	2
2	440890	DECAL - ROTO-MIX - 15-11/16" x 3 11/16"	1
3	872432	BUMPER, TRK FRT, NO ROLLER	1

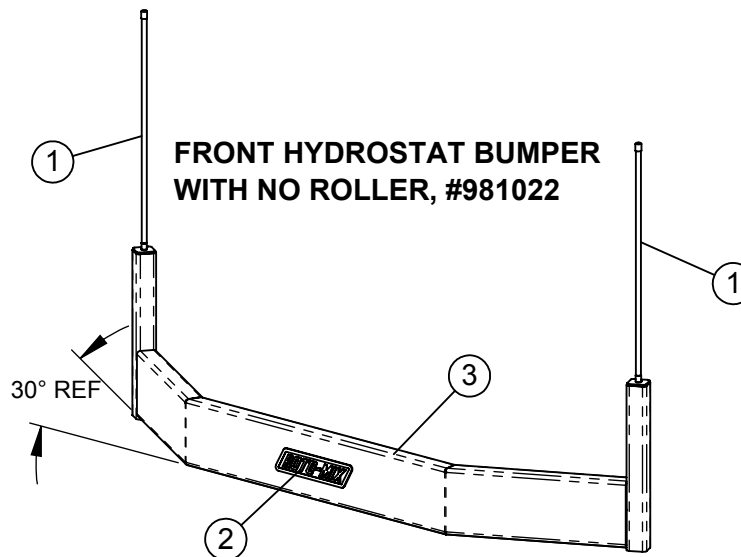

ITEM #	PART #	DESCRIPTION	QTY.
1	370334	MARKER, ORANGE STICK x 2 FT	2
2	440890	DECAL - ROTO-MIX - 15-11/16" x 3 11/16"	1
3	872433	BUMPER, TRK FRT NO ROLLER	1

TRUCK REAR BUMPER, 10", RECT. LIGHT HOLES #780948

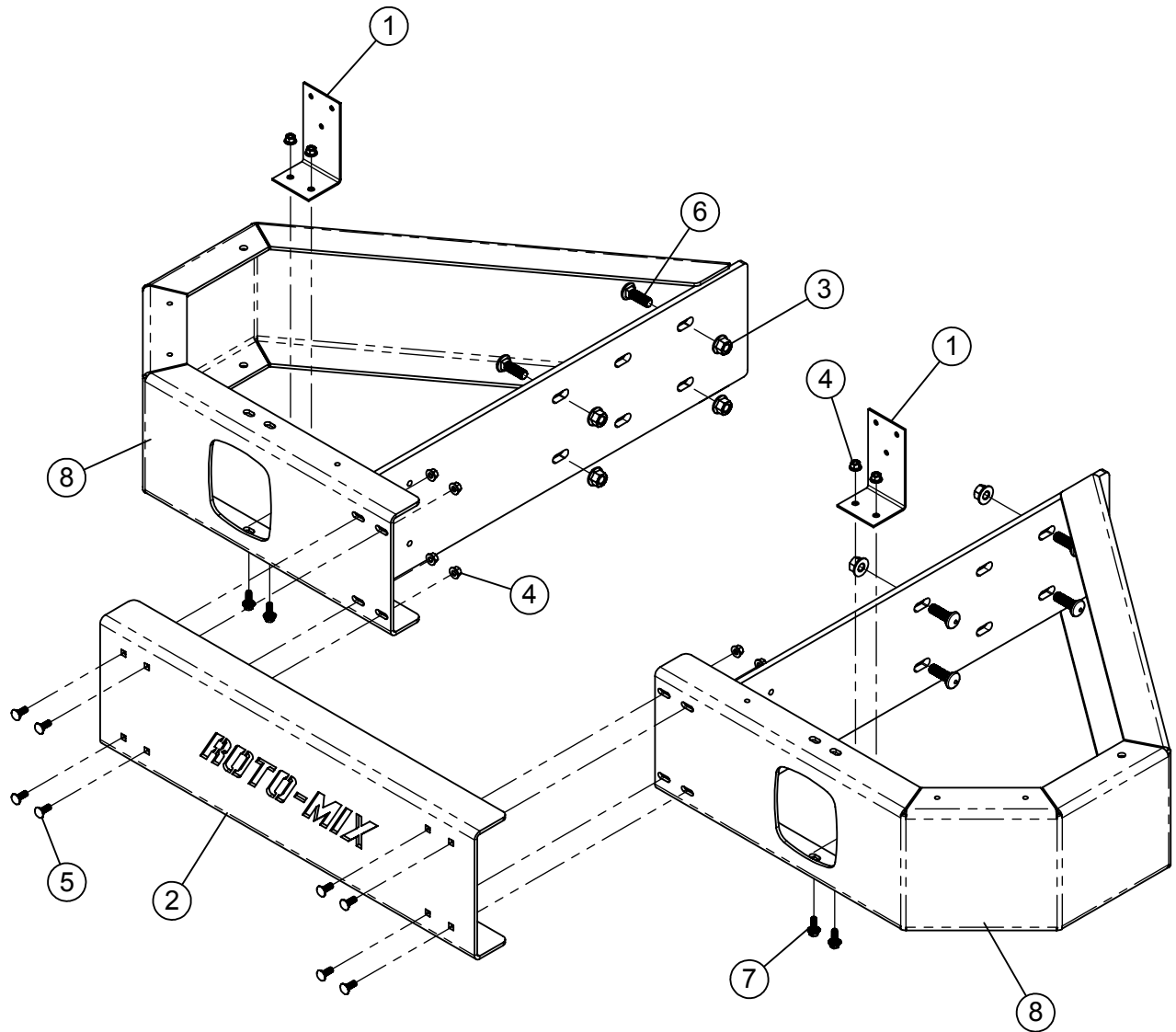

ITEM #	PART #	DESCRIPTION	QTY.
1	185600	TAIL LIGHT BRKT	2
2	192219	PLATE, FLR 10" RR BMPR ROTO-MIX	1
3	400005	FLANGE NUT, TOP LOCK. 5/8-11 GR"G"	8
4	400007	Flange Nut, Top Lock. 3/8-16 GR "G"	12
5	407040	CHCS 3/8"-16 x 1" #5 PLTD	8
6	407121	CHCS 5/8"-11 x 2" #5 PLTD	8
7	407901	HHCS 3/8"-16 X 1" SERRATED #5 PLTD	4
8	873286	BMPR, 10" REAR HALF, RECT. W.A.	2

TRUCK REAR BUMPER, 10", ROUND LIGHT HOLES #780949

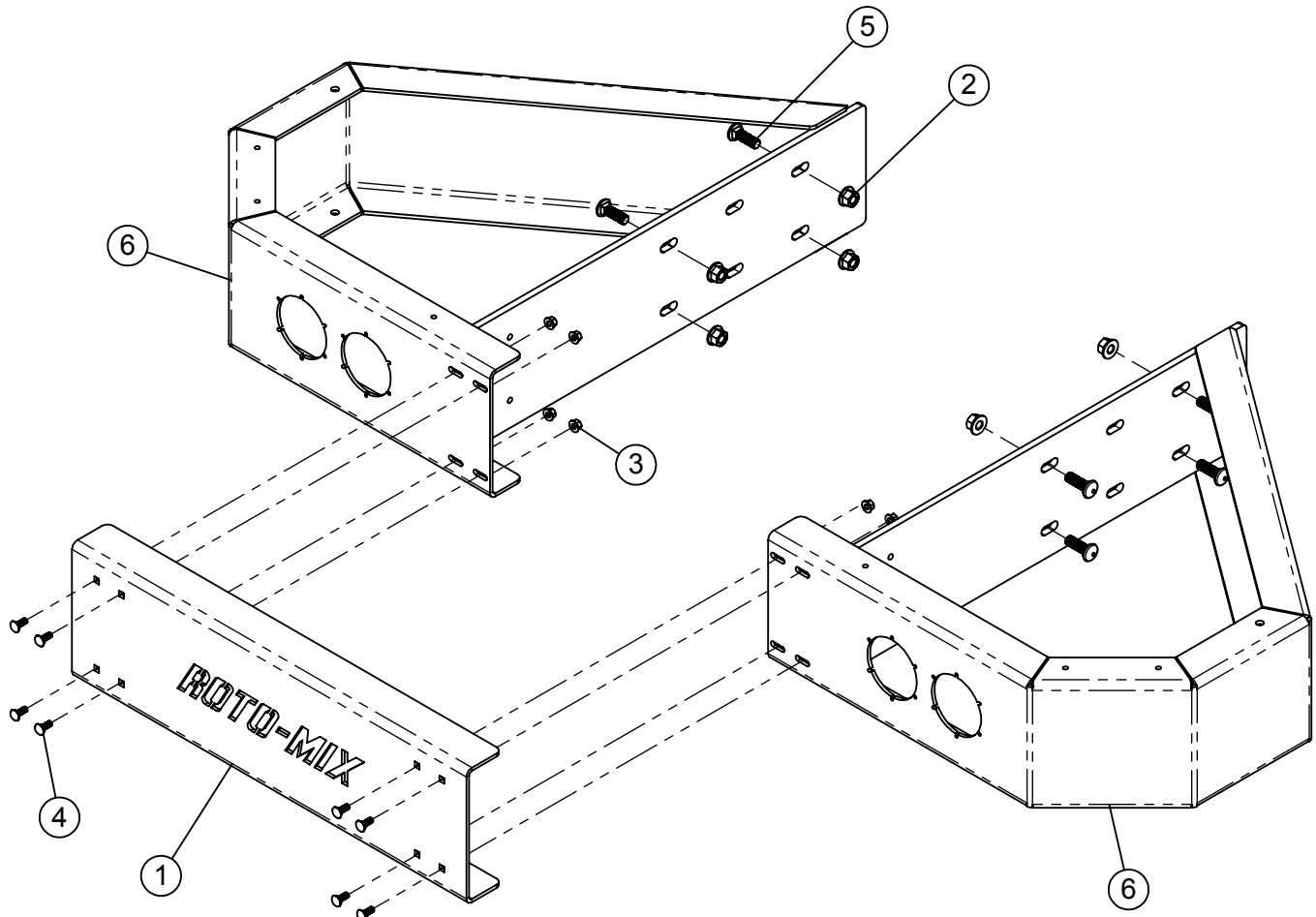

ITEM #	PART #	DESCRIPTION	QTY.
1	192219	PLATE, FLR 10" RR BMPR ROTO-MIX	1
2	400005	FLANGE NUT, TOP LOCK. 5/8-11 GR"G"	8
3	400007	Flange Nut, Top Lock. 3/8-16 GR "G"	8
4	407040	CHCS 3/8"-16 x 1" #5 PLTD	8
5	407121	CHCS 5/8"-11 x 2" #5 PLTD	8
6	873287	BMPR, 10" RR HALF RND HOLES W.A.	2